

100 kN

ZA-100 | Electromechanical actuators

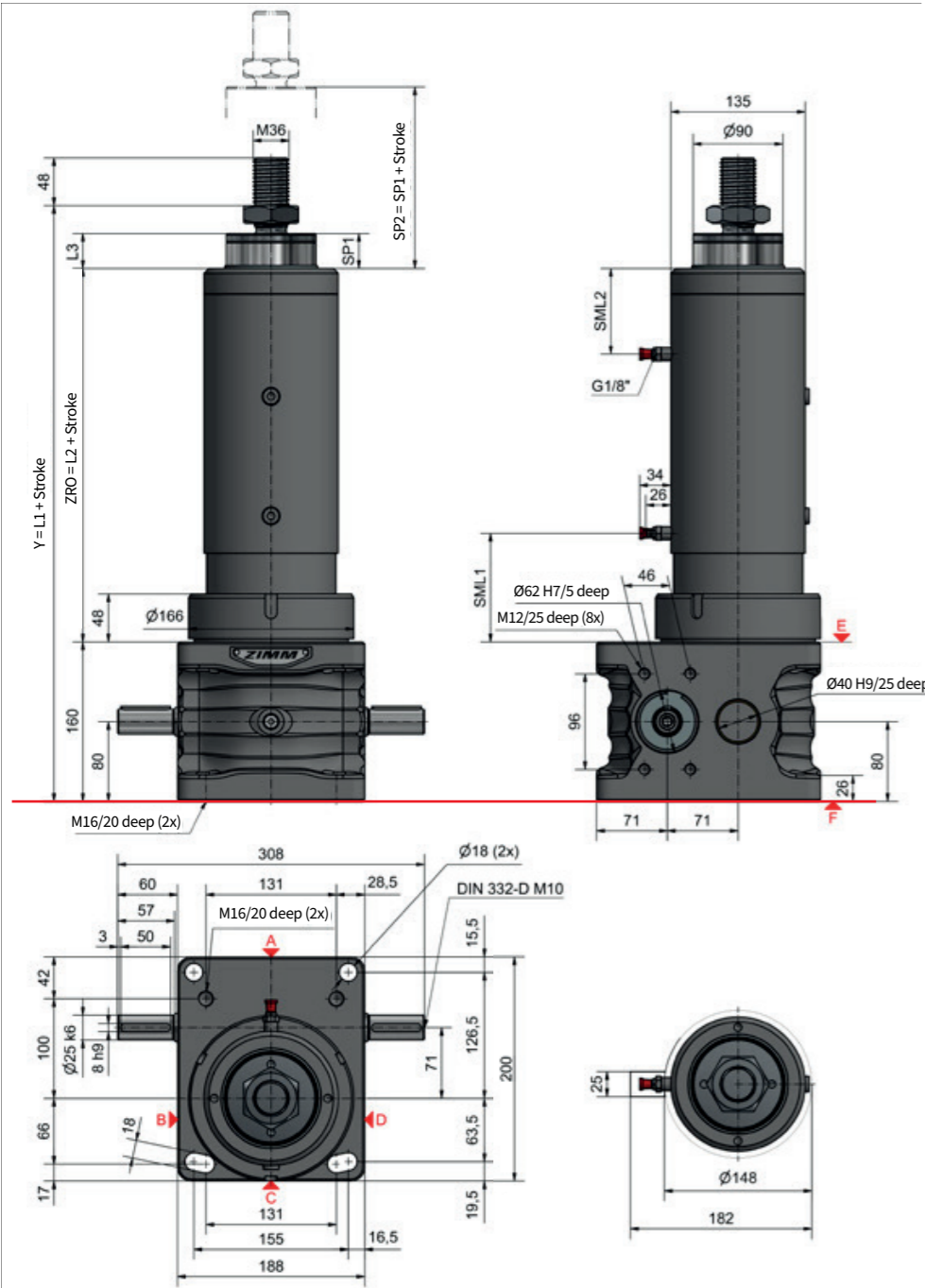

Technische Infos

ZA-100 | Critical buckling force & critical whirling speed

ON REQUEST

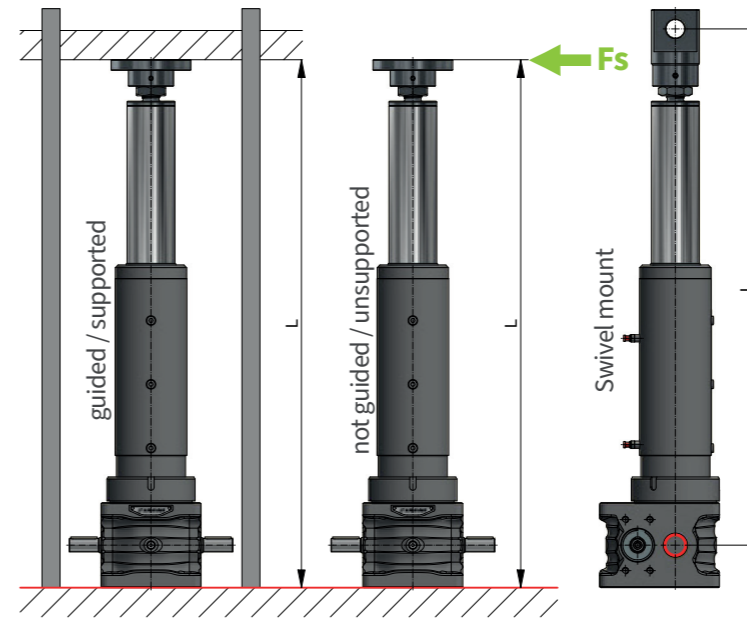

Critical whirling speed ZA-100

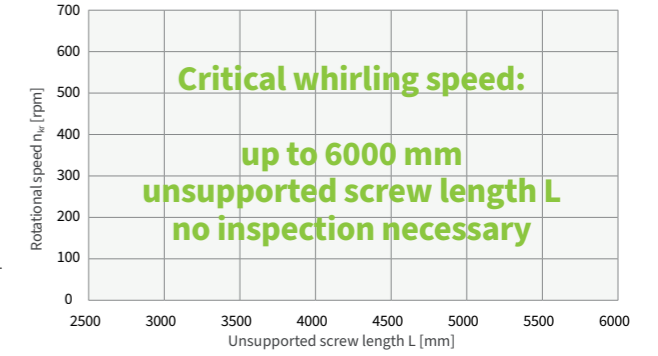

Critical buckling force ZA-100

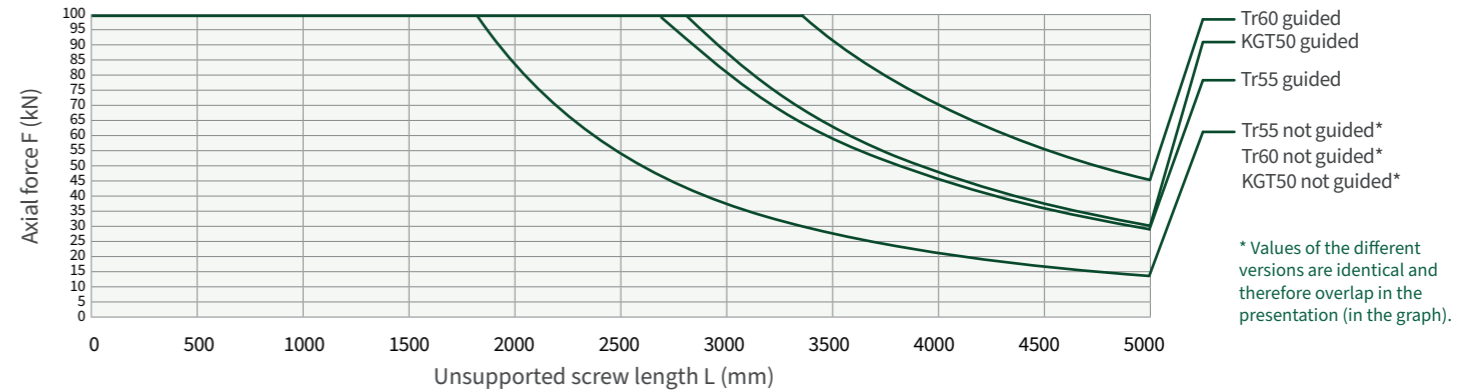

KGT load rating [kN]

	KGT50x10	KGT50x20
dyn. C	122,4	114,9
stat. C ₀	248,6	237,6

Ordering example: **ZA-100 1,00 Tr 55x9-RH -H800**



Standard configuration

Code	Ratio	Screw	Stroke per drive shaft rotation
ZA-100	36:1	Tr55x9	0,25 mm
		Tr60x9	0,25 mm
	9:1	Tr55x9	1,00 mm
		Tr60x9	1,00 mm
	36:1	KGT50x10	0,28 mm
		KGT50x20	0,56 mm
9:1	KGT50x10	1,11 mm	
	KGT50x20	2,22 mm	

Length calculations

	Standard TR	SIFA TR	KGT50x10	KGT50x20
L1	506	540	on request	on request
L2	285	319		
L3	33	33		
SP1	33	33		
SML1	99	133		
SML2	186	186		

Lubrication position SP1 corresponds to standard lubrication length SML1. Safety distance L3. For the lubrication of the screw drive and the anti-rotation lock, the lubrication positions SP1 (retracted) and SP2 (extended) must be maintained at ±2 mm.

Dynamic lateral force Fs (max.)

Fully extended L [mm]	max. Fs [N] (dynamic)	
	Standard	Heavy duty screw**
600	920	2630
700		2580
800		2220
900		1950
1000		1720
1200		1400
1500	1060	
2000	740	
2500	520	
3000	380	

For tensile loads in conjunction with lateral forces, the permissible load is limited to 60% of the nominal load (max. tensile force ZA-100 = 60kN). Part-turn actuator excluded from this limitation.

For compressive loads, the buckling diagram must also be observed.

Only with reinforced mounting component from size ZE-150

Technical data

max. compressive/tensile force:	100 kN (10 t), static
Input speed:	1500 rpm / max. 1800 rpm
Housing:	GGG, corrosion-resistant
Push rod:	steel, chrome-plated
Worm shaft:	steel, case-hardened, ground
Weight of actuator body:	64,5 kg
Weight per 100 mm stroke:	5,6 kg
Cylinder tube:	steel
Gearbox lubrication:	synthetic fluid grease
Screw lubrication:	grease lubrication
Gearbox operating temp.:	max. 60°C, higher on request
IP code:	max. IP64

**see accessories from page 15