

STRUCTURAL DESIGN

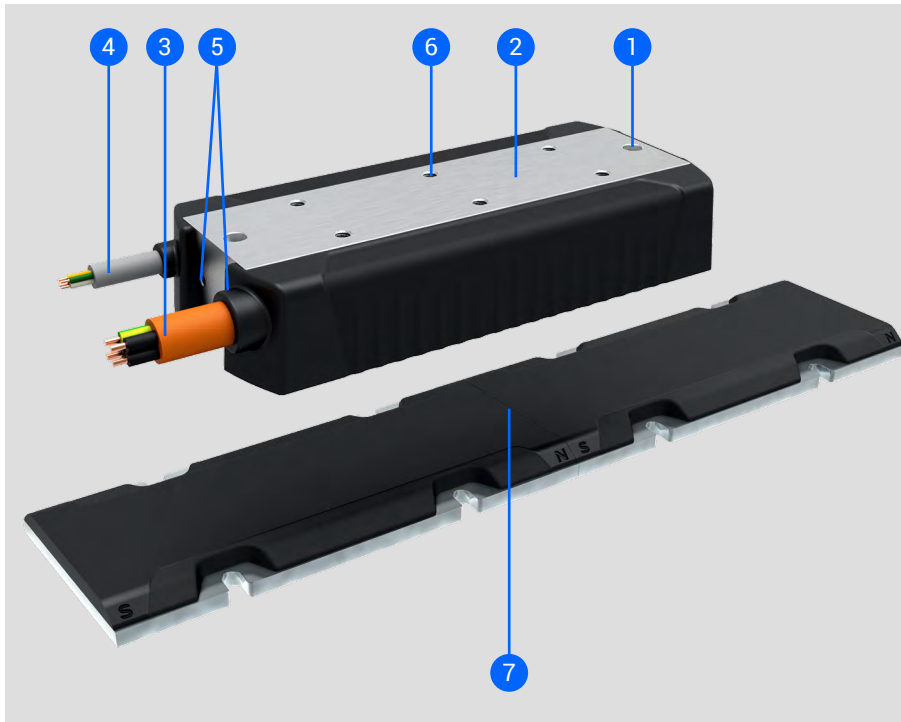

- 1 – Hole for the centering ring
- 2 – Forcer body
- 3 – Power cable
- 4 – Signal cable
- 5 – Hall sensor mounting holes
- 6 – Mounting holes
- 7 – Magnet plate

i For more information regarding the Hall sensor, please refer to page 27–28.

TERMS EXPLANATION

Supply voltage V_{DC} :

A maximum allowed supply voltage, that can be applied to the motor windings.

Continuous force F_C :

Force produced by the continuous current (I_C) at an ambient temperature of 20 °C and continuous movement of the motor. The windings temperature depends on the attached plate (heatsink) heat dissipation and airflow around the motor.

Peak force F_P :

Force produced by the peak current (I_P) for a duration of 1 second. The force is used for acceleration or deceleration.

Ultimate force F_U :

Force produced by the ultimate current (I_U) for a duration of 0,5 seconds. The force is used for acceleration or deceleration.

Attraction force of magnets F_A :

Attraction force between the forcer and the magnet plate at the defined air gap.

Cogging (detent) force F_G :

Force generated due to the interaction between the permanent magnets of the magnet plate and the mover slots. The cogging force is permanently present and is position-dependent.

Force constant K_F :

Defines how much force is produced per unit of current. It is the ratio of the force to the motor phase current.

Motor constant K_M :

The ratio of the motor force and square root of the power loss at 20 °C. The constant determines the motor's efficiency.

Back EMF phase-phase constant K_{BEMF} :

Defines the phase-to-phase voltage generated when the motor is moving at 1 m/s at the magnet temperature of 20 °C.

Continuous current I_C :

It corresponds to the continuous force (F_C) and can be continuously applied to the motor at the ambient temperature of 20 °C and continuous movement of the motor. The windings temperature depends on the attached plate (heatsink) heat dissipation and airflow around the motor.

Peak current I_P :

Corresponds to the peak force (F_P) and can be applied to the motor for 1 second.

Ultimate current I_U :

Corresponds to the ultimate force (F_U) and can be applied to the motor for 0,5 seconds.

Resistance phase-phase R_{20} :

Motor windings resistance measured phase to phase (line to line) at 20 °C.

Resistance phase-phase R_{125} :

Motor windings resistance measured phase to phase (line to line) at 125 °C.

Induction phase-phase L_P :

Motor windings inductance measured phase-to-phase (line-to-line).

Electrical time constant t_C :

The electrical time constant is the amount of time it takes for the current in the motor windings to reach 63 % of its rated value. The time constant is found by dividing inductance by resistance.

Max. winding temperature T_{max} :

Defined as a maximum permissible temperature of the motor windings. During the normal operation, it is recommended that windings temperature does not exceed 80 % of T_{max} .

Thermal resistance R_{th} :

Defines the heat transfer resistance from the motor windings to the environment at the defined plate (heatsink) and air dissipation.

Thermal resistance to heatsink R_{th-HS} :

Defines the heat transfer resistance from the motor windings to the heatsink attached surface.

Magnet pitch τ :

Magnet pitch or pole pair length is the distance between two same polar magnets on the magnet plate.

Thermal time constant τ_{th} :

Defined as a time required for the winding to reach 63 % of the max. temperature at continuous current. This value is only applicable when the mounting surface is at the constant temperature.

i Described parameters were measured with an air gap of 0,6 mm.

Continuous and attraction force as a function of an air gap

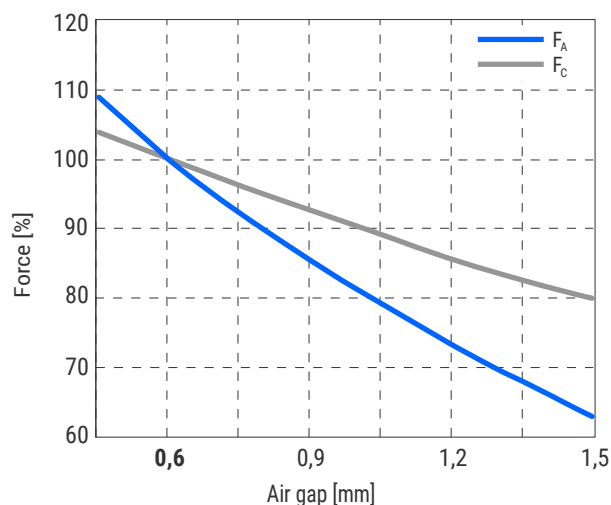

i The air gap of 0,6 mm provides an optimal continuous-to-attraction force ratio. Increasing the air gap will result in a lower attraction force, lower cogging and lower useful force.

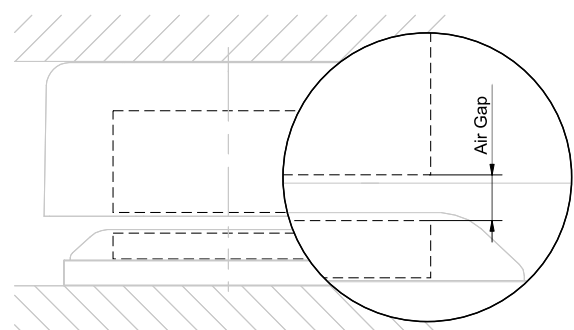

i An actual air gap between the magnet plate and coil unit is difficult to measure because of the casted finish. For an accurate measurement, the air gap can be calculated from the total mounting height.

HOW TO ORDER

Forcer order code:

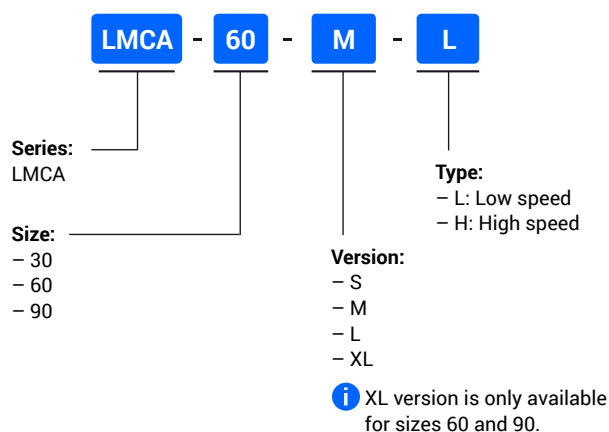

Magnet plate order code:

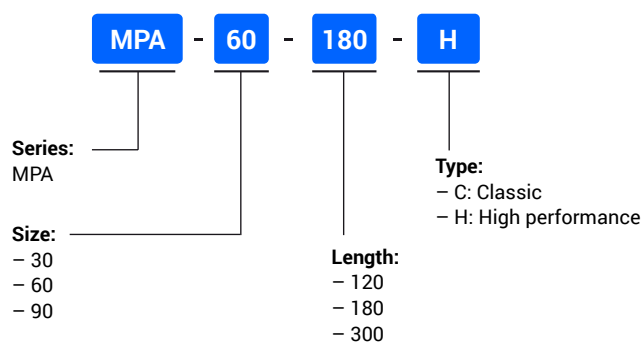

UNIMOTION

CALCULATE AND CONFIGURE YOUR OWN SOLUTION

The LINEAR MOTOR CALCULATION TOOL is an online application that enables quick and easy selection of a suitable product, with the possibility of achieving the optimal ratio between the given capacity and the price and the creation of the 3D models.

For more information please contact us or visit our website.

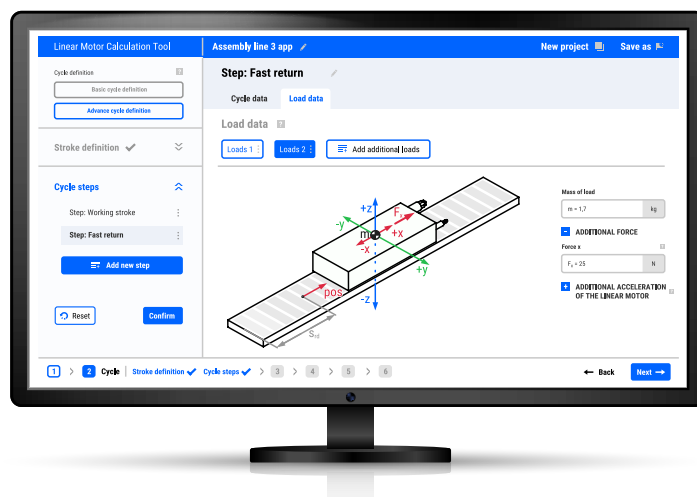

LMCA 90

General technical data

			LMCA 90																
			Version S				Version M				Version L				Version XL				
			Classic		High performance		Classic		High performance		Classic		High performance		Classic		High performance		
PARAMETER	SYM	UNIT	Low speed	High speed	Low speed	High speed	Low speed	High speed	Low speed	High speed	Low speed	High speed	Low speed	High speed	Low speed	High speed	Low speed	High speed	
PERFORMANCE	Max. supply voltage	V _{DC}	V (DC) 600																
	Continuous force ¹	F _C	N 424		472		837		934		1251		1395		1665		1856		
	Peak force (1s) ¹	F _P	N 932		1073		1842		2120		2751		3168		3661		4215		
	Ultimate force (0,5s) ¹	F _U	N 1174		1380		2320		2726		3466		4073		4611		5419		
	Attraction force of magnets ²	F _A	N 2034		2874		3735		5277		5436		7680		8838		12486		
	Force constant	K _F	$\frac{N}{A_{RMS}}$	141,3	61,7	157,3	68,7	139,5	60,9	155,7	68,0	139,0	60,7	155,0	67,7	138,8	60,5	154,7	67,5
	Motor constant	K _M	$\frac{N}{\sqrt{W}}$	34,4	34,4	38,3	38,3	48,0	48,1	53,6	53,7	58,6	58,8	65,4	65,6	67,6	67,3	75,3	75,0
	Back EMF phase-phase constant	K _{BEMF}	$\frac{V}{(m/s)}$	81,6	35,6	94,2	41,1	80,6	35,2	93,0	40,6	80,3	35,0	92,7	40,5	80,1	35,0	92,5	40,4
ELECTRICAL	Continuous current	I _C	A _{RMS} 3,0		6,9		6,0		13,7		9,0		20,6		12,0		27,5		
	Peak current	I _P	A _{RMS} 9,0		20,6		18,0		41,2		27,0		61,8		36,0		82,4		
	Ultimate current	I _U	A _{RMS} 15,0		34,3		30,0		68,7		45,0		103,0		60,0		137,4		
	Resistance at 20°C phase-phase	R ₂₀	Ω	11,24	2,14	11,24	2,14	5,62	1,07	5,62	1,07	3,75	0,71	3,75	0,71	2,81	0,54	2,81	0,54
	Resistance at 125°C phase-phase	R ₁₂₅	Ω	15,88	3,02	15,88	3,02	7,94	1,51	7,94	1,51	5,3	1,0	5,3	1,0	3,97	0,76	3,97	0,76
	Induction phase-phase	L _P	mH	68,8	13,1	68,8	13,1	34,4	6,6	34,4	6,6	22,9	4,7	22,9	4,7	17,2	3,3	17,2	3,3
	Electrical time constant ³	t _C	mS	6,1	6,1	6,1	6,1	6,1	6,2	6,1	6,2	6,1	6,6	6,1	6,6	6,1	6,1	6,1	6,1
THERMAL	Max. winding temperature	T _{max}	°C 125																
	Max. allowed magnet plate temperature	T _{magnet}	°C 90																
	Thermal time constant	τ _{th}	s 88																
	Thermal resistance	R _{th}	$\frac{K}{W}$	0,49				0,24				0,16				0,12			
	Thermal resistance to heatsink	R _{th_HS}	$\frac{K}{W}$	0,125				0,063				0,042				0,031			
MECHANICAL	Forcer overall length	M _L	mm 128																
	Forcer overall width	M _W	mm 120																
	Forcer overall height	M _H	mm 23,5																
	Forcer mass	m _m	kg 2				3,6				5,3				7				
	Magnet plate weight	m _S	$\frac{kg}{m}$	7		7,6		7		7,6		7		7,6		7		7,6	
	Forcer wires cross-section	S _C	mm ² 1,5																
	Sensor wires cross-section	S _{SC}	mm ² 0,25																
	Forcer cable length	L _M	mm 1000																
	Sensor cable length	L _S	mm 1000																
	Magnet pitch	τ	mm 30																

¹ Magnets at 20 °C

² RMS at 0 A and air gap of 0,6 mm

³ Windings at 20 °C

i The specifications were measured without forced cooling. Electrical specifications tolerance is ± 10 %.

Force as a function of velocity diagrams

Bus voltage = 325 V DC

Bus voltage = 565 V DC

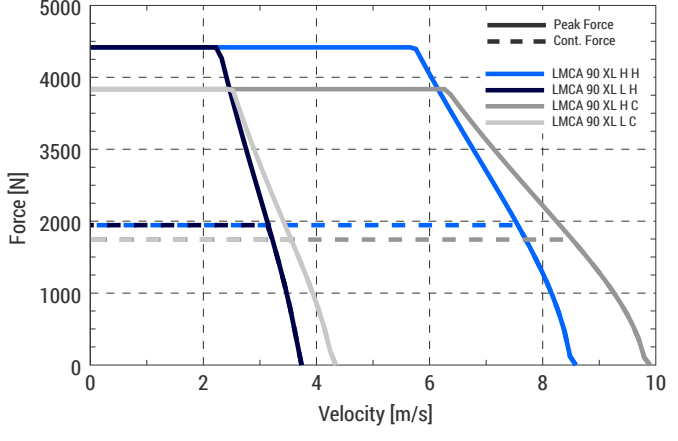
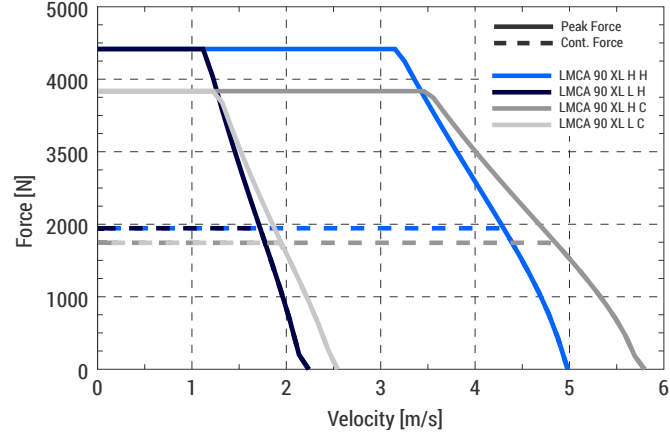
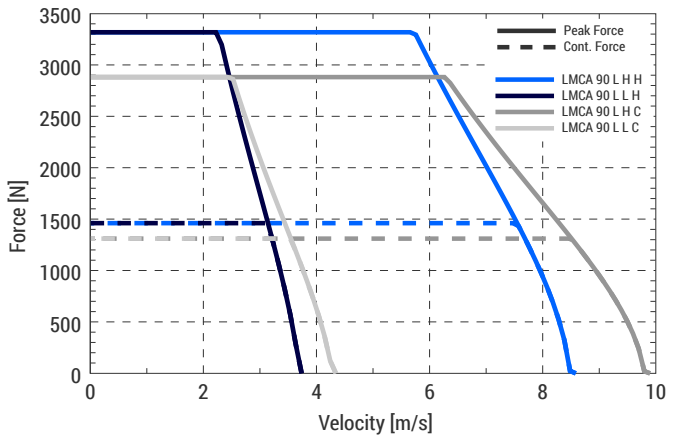
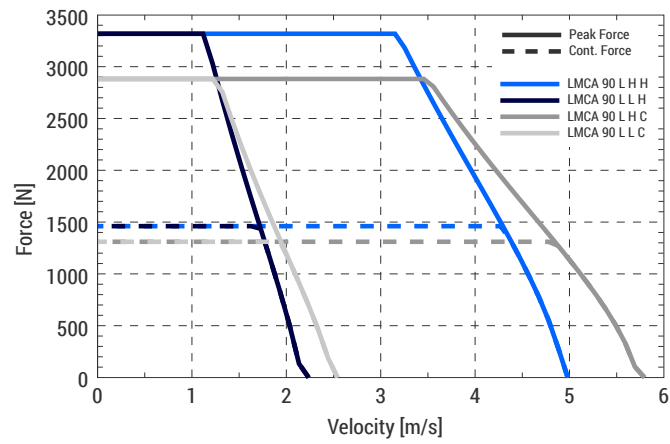
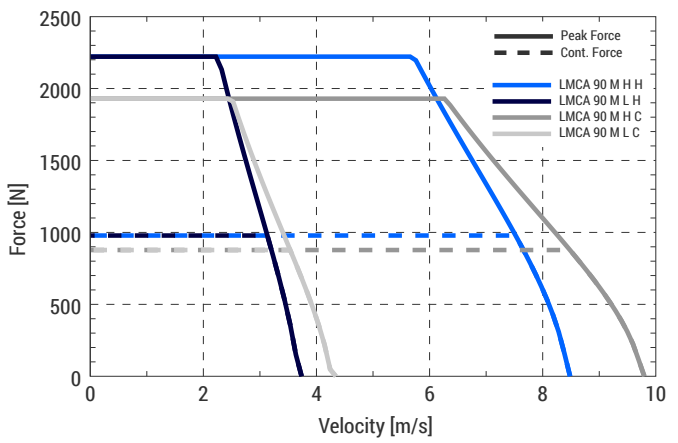
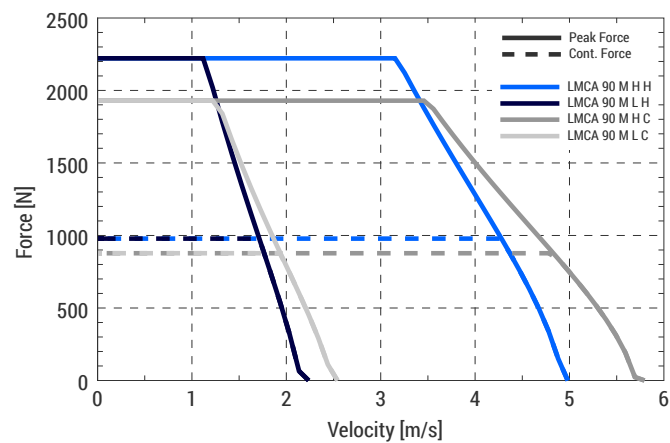
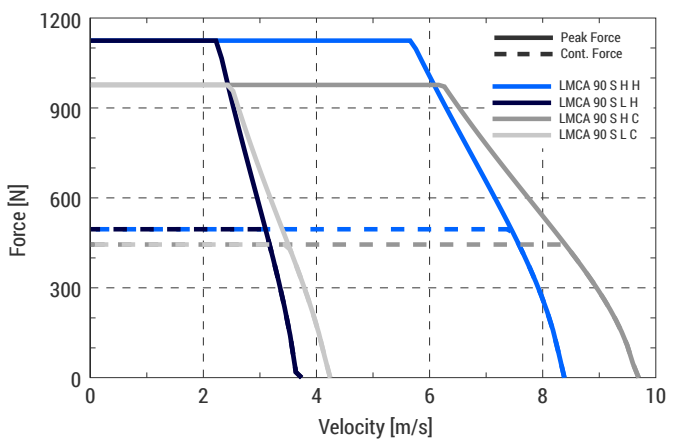
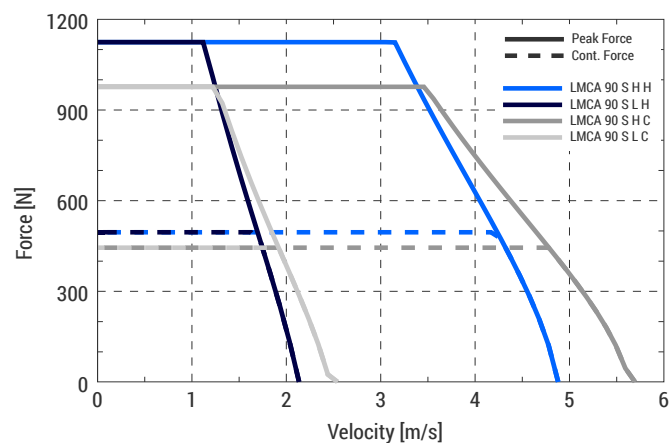

Forcer dimensions

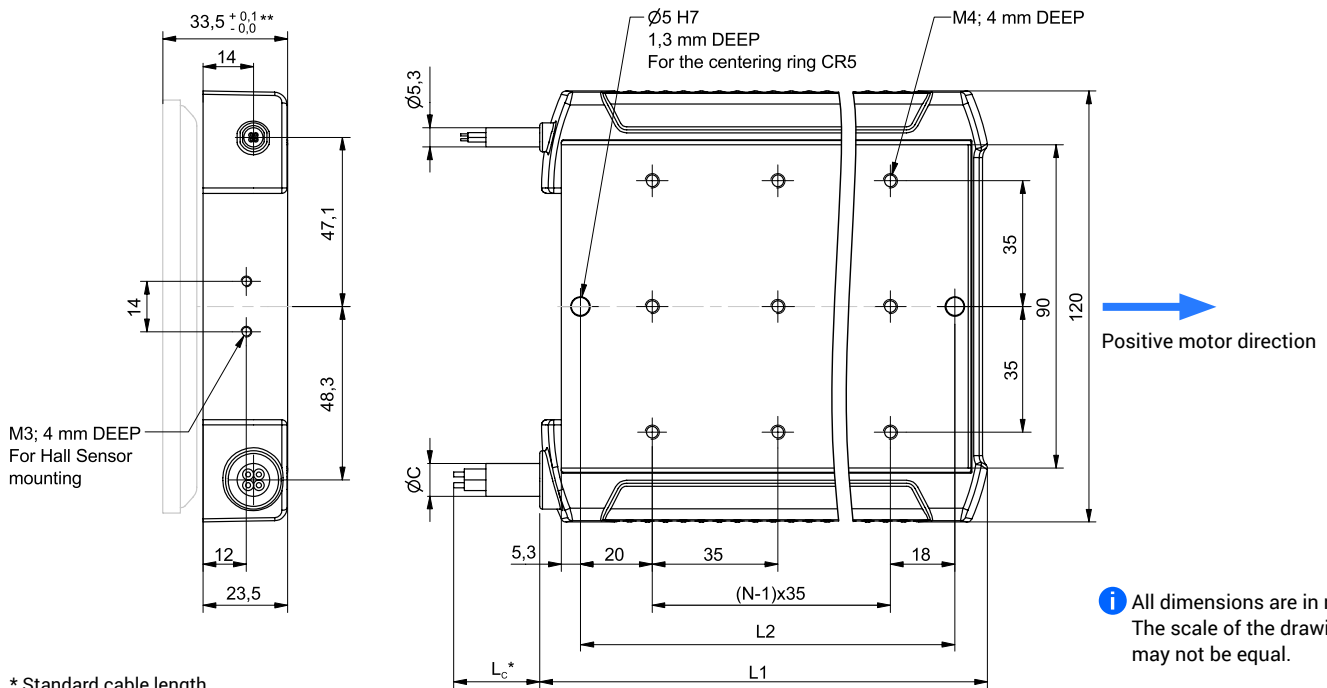

* Standard cable length
 ** The stated mounting height is set for the air gap of 0,6 mm. For more information, please refer to page 9.

LMCA 90	L1 [mm]	L2 ± 0,02 [mm]	N	ØC	L _c [mm]
LMCA 90 S H/L	128	108	3	9,1	1000
LMCA 90 M H/L	233	213	6	9,1	1000
LMCA 90 L H/L	338	318	9	10,6	1000
LMCA 90 XL H/L	443	423	12	10,6	1000

i All dimensions are in mm. The scale of the drawings may not be equal.

i 'N' is the number of mounting holes in the x-direction.

Magnet plate dimensions

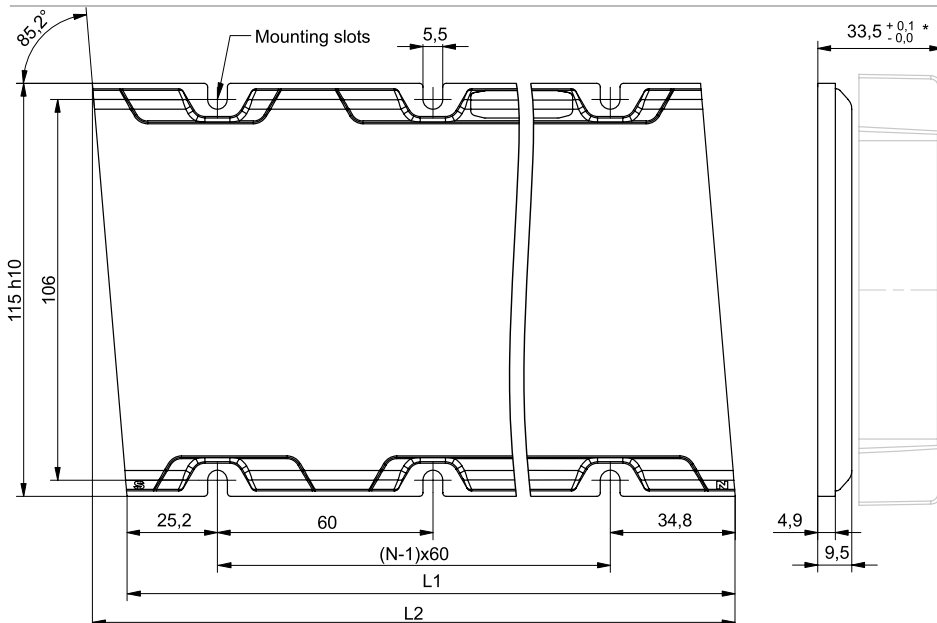

* The stated mounting height is set for the air gap of 0,6 mm. For more information, please refer to page 9.

MPA 90	L1 [mm]	L2 [mm]	N
MPA 90 120 C/H	120	129,6	2
MPA 90 180 C/H	180	189,6	3
MPA 90 300 C/H	300	309,6	5

i 'N' is the number of mounting slots in the x-direction.

MOUNTING TOLERANCES

LMCA 30

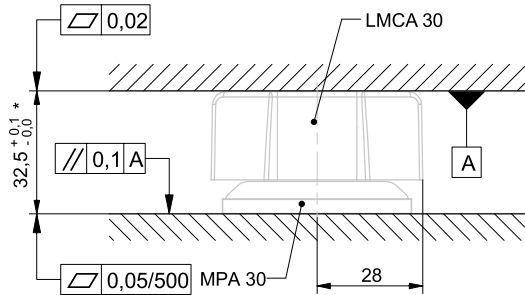

* The stated mounting height is set for the air gap of 0,6 mm.
For more information, please refer to page 9.

** We recommend using a thermally conductive paste between the forcer and heatsink to ensure a better heat transfer.

LMCA 60

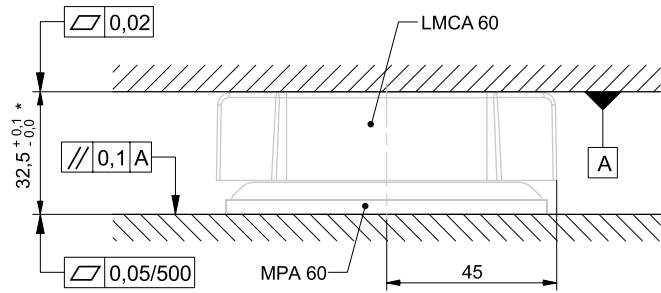

* The stated mounting height is set for the air gap of 0,6 mm.
For more information, please refer to page 9.

** We recommend using a thermally conductive paste between the forcer and heatsink to ensure a better heat transfer.

LMCA 90

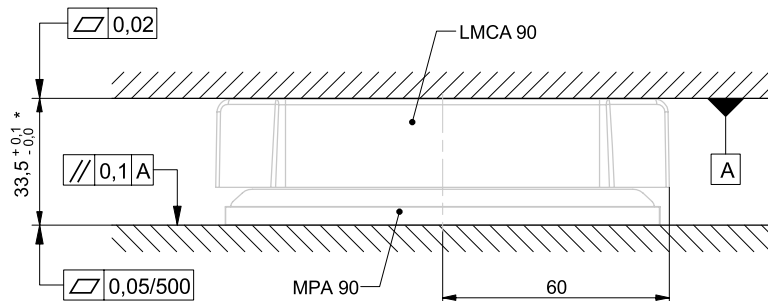

* The stated mounting height is set for the air gap of 0,6 mm.
For more information, please refer to page 9.

** We recommend using a thermally conductive paste between the forcer and heatsink to ensure a better heat transfer.

ELECTRICAL DATA

Temperature sensors description (KTY83 / PTC)

LMCA linear motors are equipped with two types of temperature sensors which are generally used for overheating protection. The first type is KTY83-122 which is thermally coupled with the U winding. The second one is the PTC, which consists of three PTCs connected in series. The PTC sensors are thermally coupled with U, V, and W windings, whereas the characteristic is harmonized by DIN 44082 standard.

The KTY83 sensor is commonly used for monitoring motor temperature, while the PTC sensor is used for cut-off protection when the motor temperature exceeds the maximum allowed temperature.

For continuous operation, it is recommended that the motor temperature does not exceed 80 % (100 °C) of the maximum allowed motor temperature (125 °C).

PTC Thermistor

As mentioned in the above description, windings are equipped with three PTC thermistors connected in series. This sensor's characteristic curve has an exponential rise when the temperature of the windings is approaching the maximum temperature of 125 °C. Therefore it can be used as an indicator of signaling critical temperature, which eliminates the need for sensing electronics. With this particular sensor, it is not possible to receive the exact temperature.

In the table below, resistances at specific temperatures are presented.

Resistance of PTCs at ambient temperature (25 °C)	< 300 Ω
Normal operating PTCs resistance (25 °C–120 °C)	< 3000 Ω
Cut-off resistance of PTCs	> 3990 Ω

i The resistance is the sum of all three PTCs.

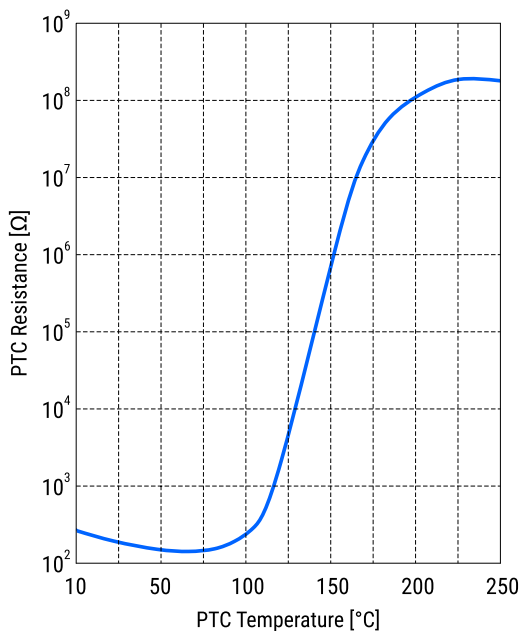

KTY83-122 Thermistor

As mentioned above, the forcer is equipped with one KTY83-122 thermistor. This sensor's characteristic curve is nearly linear through the whole operating range. The thermal time constant of this sensor is approximately 6 seconds.

With the below equation, you can calculate the temperature of the windings from the current resistance of this KTY83-122 sensor.

The temperature of the windings can be calculated from the current resistance of the KTY83 sensor with the use of the below equation.

$$T = 25 + \frac{\sqrt{\alpha^2 - 4 * \beta + 4 * \beta * \frac{R_T}{R_{25}} - \alpha}}{2 * \beta}$$

Values of specific elements are:

Parameter	Value	Unit
R _T	*Current sensor reading*	Ω
α	7,88E-03	K ⁻¹
β	1,94E-05	K ²
R ₂₅	1010	Ω

In the table below, resistance values of KTY83 at specific temperatures are presented.

T [°C]	25	30	40	50	60	70	80	90	100	110	120	125	130
R [Ω]	1010	1049	1130	1214	1301	1392	1487	1585	1687	1792	1900	1956	2012

Resistance of KTY at ambient temperature (25 °C)	1010 Ω
Normal operating KTYs resistance (25 °C–120 °C)	< 1900 Ω
Cut-off resistance of KTY	> 1956 Ω

Pin layout

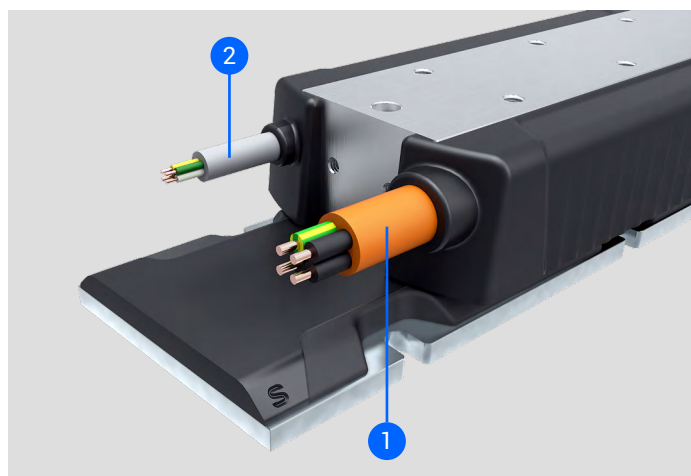

- 1 – Power cable
 - Black: Phase cables (L1, L2, L3)
 - Yellow: Neutral (N) + Ground (Protective Earth, PE)
- 2 – Temperature sensor cable
 - Yellow & Green: PTC Thermistors
 - White & Brown: KTY Thermistor