

STANDARD FEATURES	
Stage	Vertical Stage
Travel	60mm to >200mm
Motor	Direct Drive Ironless Core Linear Motor
Feedback	Non-Contact Incremental Optical Linear Encoder Optional: Non-Contact Absolute Optical Linear Encoder
Scale	20um Pitch Gold Tape Scale Optional: 20um Pitch Near Zero CTE ZeroMet Scale Optional: Absolute Stainless Steel or Near Zero CTE ZeroMet Scale
Resolution	1Vp-p Sin-Cos Analog Output (~4.88nm with 4096 Interpolation) Digital AQB options available between 1nm and 5um (reduced speeds may apply) Absolute options available between 1nm and 100nm
Sensors	Integrated Optical Latching Home Index and End of Travel Magnetic NPN Limits
Bearings	High Precision Crossed Roller Bearings
Counterbalance	Frictionless Air Bearing Pneumatic Cylinder (regulator included)
Cables	High Flex, 10M Cycle, 3m Length from Component (Standard) (some length consumed inside stage), ~5mm OD, 20mm Dynamic Bend Radius (Motor and Encoder)
Hard Stops	Integrated End-of-Travel Hard Stops
Orientation	Vertical Axis
Structure	Black Anodized Aluminum 6061-T6
Maintenance	Stages are Greased for Life in Normal Environment; No Maintenance
Environment	Standard Optional: Clean Room
Temperature	Operating: 0°C to 50°C (performance not guaranteed throughout entire range) Storage/Transport: -20°C to 70°C
Humidity	10% to 80% Non-Condensing
Precision	6-D Nano Precision™ Test Methods

TRAVEL	OPTION	LENGTH	WIDTH	HEIGHT	A (inch)	B (inch)	C	D	G	H	I	J	K	L	M	S	T
60		183.5	45	220	6	3	100	100	50	M6	166	84	153	50	60	M6 OR 1/4-20	M5 (6X)
100		183.5	50	323	9	3	100	100	75	M6	245	122	179	50	60	M6 OR 1/4-20	M5 (10X)
100	-HF	215	50	323	9	3	100	120	75	M6 (8X)	245	122.5	179	25	60	M5 OR 10-24	M5 (14X)
150		200	50	353	10	3	100	100	75	M6	273	137.5	164	25	60	M6 OR 1/4-20	M5 (18X)
150	-HF	215	50	353	10	3	100	120	75	M6 (8X)	273	137.5	179	25	60	M6 OR 1/4-20	M5 (18X)
200		230	50	484	13	3	100	120	50	M6 (8X)	365	170	195	25	75	M6 OR 1/4-20	M5 (18X)

* All units millimeters unless otherwise noted.
 * All hole patterns centered on M5 dowel pin hole at center of stage or base.
 * Custom and larger sizes available.
 * All dimensions and visual representations reflect stage at mid-stroke or home position.

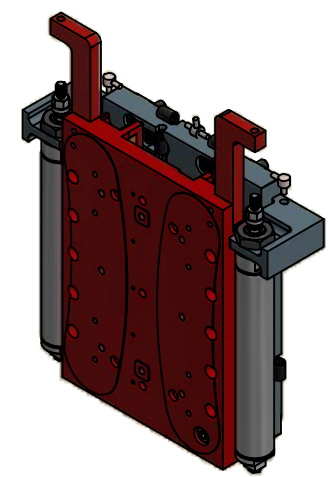
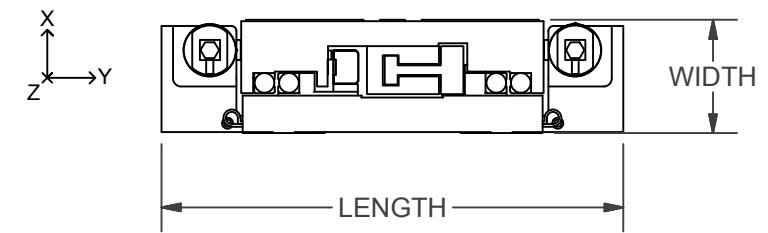

DRAWN	QWOLF	2020-12-01
CHECKED		
Tolerances: Surface Roughness: x.x \pm 0.5 mm x.xx \pm 0.13 mm x.xxx \pm 0.05 mm ANGLES \pm 0.5° MATERIAL FINISH SEE NOTES		

AI-LM-(TRAVEL)00-Z-ABCB-(OPTION)		
SIZE	DWG NO	REV
B	0010-08060	002
SCALE	0090-07999-016 ALIO STD TEMPLATE	SHEET 1 OF 2

NOTE: MODEL AI-LM-6000-Z-ABCB SHOWN.



ALIO STAGE AND MOTOR SPECIFICATIONS

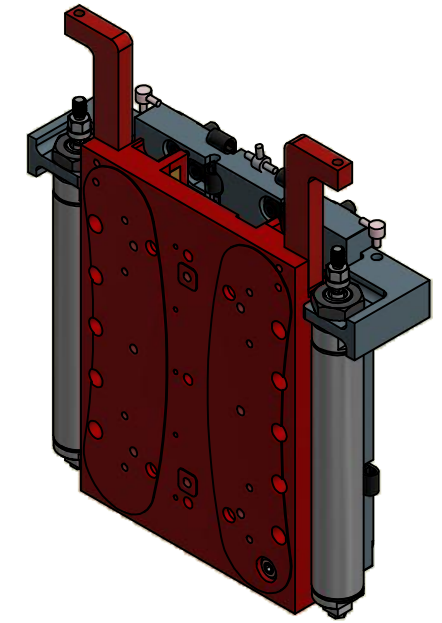

MODEL	UNITS	AI-LM-6000-Z-ABCB			AI-LM-10000-Z-ABCB			AI-LM-10000-Z-ABCB-HF			AI-LM-15000-Z-ABCB			AI-LM-15000-Z-ABCB-HF			AI-LM-20000-Z-ABCB		
NOMINAL TRAVEL FROM HOME INDEX	mm	+/- 30			+/- 50			+/- 50			+/- 75			+/- 75			+/- 100		
MAGNETIC LIM LOCATIONS (+1/-3mm)	mm	+/- 31			+/- 50			+/- 50			+/- 75			+/- 75			+/- 100		
HARD STOP LOCATIONS (+/-1mm)	mm	+/- 32			+/- 52			+/- 52			+/- 77			+/- 77			+/- 102		
PERFORMANCE SPECIFICATIONS [1]		(STD)	ULTRA	NANO	(STD)	ULTRA	NANO	(STD)	ULTRA	NANO	(STD)	ULTRA	NANO	(STD)	ULTRA	NANO	(STD)	ULTRA	NANO
LINEAR DISPLACEMENT ACCURACY	um	+/- 3.0	+/- 0.5	+/- 0.2	+/- 3.0	+/- 0.7	+/- 0.3	+/- 3.0	+/- 0.7	+/- 0.3	+/- 3.0	+/- 0.7	+/- 0.4	+/- 3.0	+/- 0.7	+/- 0.4	+/- 3.0	+/- 1.0	+/- 0.4
BIDIRECTIONAL REPEATABILITY	nm	+/- 75			+/- 45			+/- 75			+/- 45			+/- 75			+/- 45		
HOME INDEX BIDIRECTIONAL REPEATABILITY		< +/- 1 encoder count																	
RESOLUTION	--	Standard: ~4.88nm with 4096 Interpolation (Digital AQB options available between 1nm and 5um) (Absolute option available between 1nm and 100nm)																	
STRAIGHTNESS IN Y		+/- 2.5	+/- 1.5	+/- 1.0	+/- 2.5	+/- 1.5	+/- 1.0	+/- 2.5	+/- 1.5	+/- 1.0	+/- 2.5	+/- 1.5	+/- 1.2	+/- 2.5	+/- 1.5	+/- 1.2	+/- 3.0	+/- 2.0	+/- 1.5
STRAIGHTNESS IN X [2]		+/- 2.0	+/- 1.0		+/- 2.0	+/- 1.0		+/- 2.0	+/- 1.0		+/- 3.0	+/- 1.5		+/- 3.0	+/- 1.5		+/- 3.0	+/- 1.5	
PITCH ABOUT Y [2]		+/- 10.0			+/- 10.0			+/- 10.0			+/- 15.0			+/- 15.0			+/- 7.5		
PITCH ABOUT X		+/- 10.0			+/- 10.0			+/- 10.0			+/- 15.0			+/- 15.0			+/- 7.5		
PITCH ABOUT Z		+/- 6.0			+/- 6.0			+/- 6.0			+/- 8.0			+/- 8.0			+/- 4.0		
MOTION PROFILE SPECIFICATIONS																			
MAX VELOCITY [3]	m/s	0.25			0.25			0.25			0.25			0.25			0.25		
MAX PEAK ACCELERATION [3]	G	2.5			3.5			4.5			2.5			4.0			2.5		
MAX PAYLOAD CAPABILITY	kg	10			12			25			25			25			25		
ASSEMBLY MASS	kg	2.9			4.7			5.9			5.6			6.5			9.0		
MOVING MASS	kg	1.5			2.6			3.3			3.1			3.7			5.0		
COUNTERBALANCE SPECIFICATIONS																			
MAXIMUM ALLOWED PRESSURE	Mpa	0.7																	
COUNTERBALANCE CONSTANT [9]	N/Mpa	400			400			900			900			900			900		
COUNTERBALANCE SUPPLY HOSE	--	4mm																	
MAXIMUM LEAK RATE @ 0.2MPa [9]	SL/min	12			12			18			18			18			18		
MOTOR INFORMATION																			
MOTOR TYPE	--	LINEAR BRUSHLESS SERVO MOTOR																	
MOTOR MODEL	--	AI-LM-144ASN-D			AI-LM-144BSN-D			AI-LM-256BSN-D			AI-LM-144BSN-D			AI-LM-256BSN-D			AI-LM-256BSN-D		
MAGNETIC PITCH (N-N)	mm	30.48																	
MAX VOLTAGE (LINE TO LINE) [4]	V	500																	
ELECTRICAL TIME CONSTANT	msec	0.22			0.22			0.2			0.22			0.2			0.2		
MAX MOTOR TEMP	°C	125			125			130			125			130			130		
MOTOR THERMISTOR (options available)	--	NEGATIVE COEFFICIENT THERMISTOR: GE TYPE AL03006-5818-97-K, MATERIAL: GE9.7A																	
MOTOR CONNECTION	--	DELTA																	
MOTOR CONSTANT	N/sqrt(W)	2.96			4.18			7.04			4.18			7.04			7.04		
FORCE CONSTANT	N/Apk	8.4			16.8			28.7			16.8			28.7			28.7		
PHASE RESISTANCE (@ 25°C) [5]	Ohm	5.79			11.60			11.74			11.60			11.74			11.74		
PHASE RESISTANCE (@ MAX°C) [5]	Ohm	8.04			16.07			16.59			16.07			16.59			16.59		
INDUCTANCE @ 1kHz	mH	1.3			2.5			2.3			2.5			2.3			2.3		
CONTINUOUS FORCE [6]	N	26.7			53.3			93.1			53.3			93.1			93.1		
CONTINUOUS CURRENT [6]	Apk	3.18			3.18			3.25			3.18			3.25			3.25		
PEAK FORCE [7]	N	84			169			295			169			295			295		
PEAK CURRENT [7]	Apk	10.06			10.06			10.27			10.06			10.27			10.27		
BACK EMF CONSTANT	V/m/s	8.4			16.8			28.7			16.8			28.7			28.7		

CUSTOMER SUPPLIED AIR QUALITY	
AIR SUPPLY MUST BE FREE OF CONTAMINANTS AND MOISTURE (<85% RELATIVE HUMIDITY). FILTERED AIR SUPPLY TO ISO 8573.1 QUALITY CLASS 3 OR BETTER	
CLASS 2 (RECOMMENDED)	
DIRT	1um PARTICAL SIZE OR SMALLER
WATER	-40°C, PRESSURE DEWPOINT (16 PPM VOL.) AT 0.7MPa
OIL	1.0 mg/m³ (INCLUDING VAPOR)
CLASS 3 (MINIMUM)	
DIRT	5um PARTICAL SIZE OR SMALLER
WATER	-20°C, PRESSURE DEWPOINT (128 PPM VOL.) AT 0.7MPa
OIL	1.0 mg/m³ (INCLUDING VAPOR)
SMC precision regulator supplied with stage: ARP20-N02EH-Z	

ALIO INDUSTRIES PROPRIETARY DOCUMENT
 5335 XENON ST, ARVADA, CO 80002 USA
 (Tel) 303.339.7500 - WWW.ALIOINDUSTRIES.COM

- Notes:
- Specifications measured on stage centerline at nominal 20°C, ~50mm above mounting surface with no payload. For up to 150mm catilever payloads. Contact ALIO for greater distances. Standard describes typical values, Ultra and Nano are guaranteed. ALIO provides NIST traceable proof for all options/specs per quote.
 - Flatness and Pitch specifications dependent on system base. Contact ALIO for more information.
 - Axis limitation at no payload. Based on 100% S-curve profile. Does not account for limitations due to amplifier, resolution, position error, or duty cycle.
 - Back EMF plus IR drop must not exceed maximum line to line bus voltage.
 - Resistance values do not include cable resistance. Cable resistance adds 0.146 ohm/m.
 - Continuous operating limits are based on continuous operation at maximum temperature with aluminum heat sink (300mm x 12.5mm x motor length).
 - Maximum on time at peak operating limits is 10 seconds.
 - All electrical specifications may vary by 12% from listed values.
 - For estimation only. Fine tuning needs to be performed on every unit individually.
 - Additional motor and travel options are available for each stage for optimized performance as necessary per customer requirements.

DRAWN	QWOLF	2020-12-01
CHECKED		
Tolerances: Surface Roughness: x.x ± 0.5 mm x.xx ± 0.13 mm x.xxx ± 0.05 mm ANGLES ± 0.5° MATERIAL FINISH SEE NOTES		

TITLE		
AI-LM-(TRAVEL)00-Z-ABCB-(OPTION)		
SIZE	DWG NO	REV
B	0010-08060	002
SCALE	0090-07999-016 ALIO STD TEMPLATE	SHEET 2 OF 2