



Stainless products



overview

Stainless products

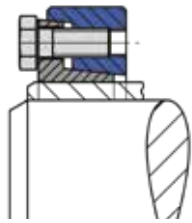

3173 1.4122 Shrink Disc 2-parts

Mini-Range, Medium corrosion resistance **page 180**

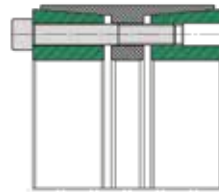

3012 S2 Locking Assembly

Very good self-centering, Wide installation length, Medium corrosion resistance **page 190**

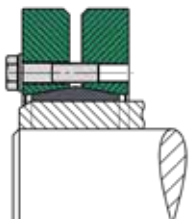

3071 1.4122 Shrink Disc 3-parts

Standard-Range, Medium corrosion resistance **page 184**

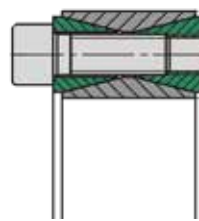

3020 S2 Locking Assembly

No self-centering, Short installation length, Medium corrosion resistance **page 192**

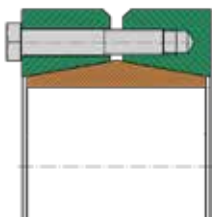

W 1.4122 Shaft Coupling

Short shaft distance, Medium corrosion resistance **page 186**



3173 1.4122 2-parts (stainless)

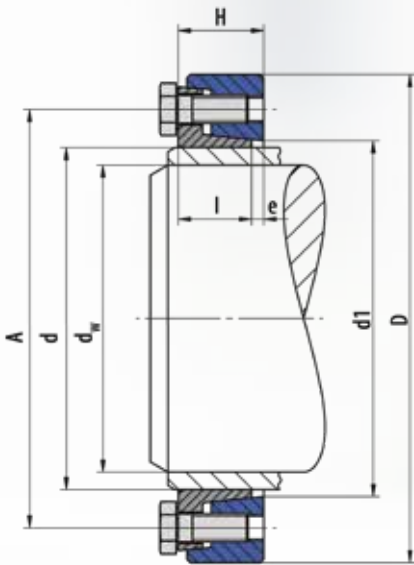

Used symbols

d	[mm]	Nominal diameter of the shrink disc
d_w	[mm]	Shaft diameter
M_{max}	[mm]	Maximal transmittable torque
D	[mm]	Outer diameter
l	[mm]	Length of the bush
e	[mm]	Excess length
H	[mm]	Width of the shrink disc
A	[mm]	Pitch circle diameter
d1	[mm]	Attachment size
M_A	[Nm]	Tightening torque of the clamping screws
Z		Number of clamping screws
S		Size of the clamping screws
n_{max}	[min-1]	Permitted rotational frequency
pN	[N/mm ²]	Moderate pressure to the hub
I	[kgm ²]	Moment of inertia

Design of the shrink disc

- Without Washers
- Bush complete slit
- Dimensions H & e in unlocked position

min. yield strength Rp0,2	N/mm ²
solid shaft	240
Hub	290

Variation from the standard shaft diameter d_w

> mm	≤ mm	minimal - mm	maximal + mm
20	60	-2	1
60	100	-2	2
100	160	-3	2
160	220	-4	2
220	300	-5	2

$$M = M_{max(Catalog)} \left(\frac{d_w(target)}{d_w(Catalog)} \right)^2$$

(see Basics - Calculation)

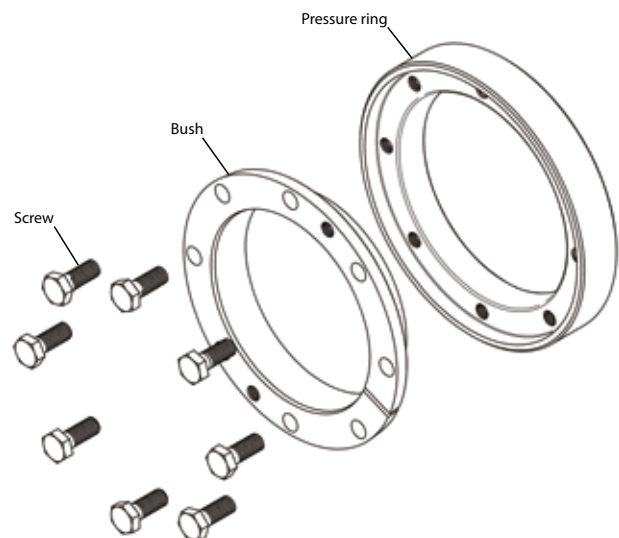

Ordering information: TAS 3173-d (e.g.: TAS 3173-100 1.4122 ... further sizes on request)

3173 1.4122 2-parts (stainless)

<i>d</i> mm	<i>d_w</i> mm	<i>M_{max}</i> Nm	<i>D</i> mm	<i>l</i> mm	<i>e</i> mm	<i>H</i> mm	<i>A</i> mm	<i>d₁</i> mm	<i>M_A</i> Nm	<i>Z</i> Stk	<i>S</i>	<i>DIN</i>	<i>Class</i>	<i>n_{max}</i> min ⁻¹	<i>p_N</i> N/mm ²	<i>I</i> kgm ²	<i>Weight</i> kg
24	20	85	50	11	2,5	13,5	38	25	8	6	M 6 x 12	933	A4-K80	11400	161	0,0000538	0,14
29	25	135	58	11	2,5	13,5	44	32	8	6	M 6 x 12	933	A4-K80	9800	150	0,0000964	0,18
34	29	160	64	11	2,5	13,5	50	38	8	6	M 6 x 12	933	A4-K80	8900	134	0,0001402	0,21
35	29	150	64	11	2,5	13,5	50	38	8	6	M 6 x 12	933	A4-K80	8900	135	0,0001387	0,21
38	34	235	69	11	2,5	13,5	55	43	8	6	M 6 x 12	933	A4-K80	8300	123	0,0001869	0,24
40	35	240	69	11	2,5	13,5	55	43	8	6	M 6 x 12	933	A4-K80	8300	124	0,0001826	0,23
44	36	280	80	15	3	18	62	49	8	6	M 6 x 16	933	A4-K80	7100	141	0,0004609	0,44
46	38	330	80	15	3	18	62	49	8	6	M 6 x 16	933	A4-K80	7100	142	0,0004518	0,42
47	40	400	80	15	3	18	62	49	8	6	M 6 x 16	933	A4-K80	7100	144	0,0004469	0,42
51	44	550	85	15	3	18	67	54	8	6	M 6 x 16	933	A4-K80	6700	124	0,0005627	0,46
56	48	570	90	15	3	18	72	59	8	8	M 6 x 16	933	A4-K80	6300	132	0,0006908	0,49
57	48	570	90	15	3	18	72	59	8	8	M 6 x 16	933	A4-K80	6300	130	0,0006818	0,48
61	53	680	95	15	3	18	76	64	8	8	M 6 x 16	933	A4-K80	6000	122	0,0008373	0,53
65	58	740	100	15	3	18	82	69	8	8	M 6 x 16	933	A4-K80	5700	108	0,0010174	0,57
66	58	740	100	15	3	18	82	69	8	8	M 6 x 16	933	A4-K80	5700	110	0,0010035	0,56
70	62	910	115	21	3	24	94	77	19	6	M 8 x 20	933	A4-K80	4900	106	0,0026163	1,15
72	63	940	115	21	3	24	94	77	19	6	M 8 x 20	933	A4-K80	4900	107	0,0025666	1,12
73	63	940	115	21	3	24	94	77	19	6	M 8 x 20	933	A4-K80	4900	111	0,0025402	1,10
75	67	1140	120	21	3	24	100	82	19	6	M 8 x 20	933	A4-K80	4700	101	0,0030441	1,21
76	68	1210	120	21	3	24	100	82	19	6	M 8 x 20	933	A4-K80	4700	103	0,0030170	1,20
78	68	1210	120	21	3	24	100	82	19	6	M 8 x 20	933	A4-K80	4700	102	0,0029536	1,15
81	73	1240	125	21	3	24	104	87	19	8	M 8 x 20	933	A4-K80	4500	92	0,0034868	1,26
83	75	1380	125	21	3	24	104	87	19	8	M 8 x 20	933	A4-K80	4500	95	0,0034103	1,21
85	77	1420	130	21	3	24	110	92	19	8	M 8 x 20	933	A4-K80	4400	92	0,0040762	1,35
86	78	1470	130	21	3	24	110	92	19	8	M 8 x 20	933	A4-K80	4400	92	0,0040037	1,32
88	80	1470	130	21	3	24	110	92	19	8	M 8 x 20	933	A4-K80	4400	95	0,0039124	1,27
93	83	1630	135	21	3,5	24,5	114	97	19	8	M 8 x 20	933	A4-K80	4200	92	0,0044621	1,33
94	85	1800	135	21	3,5	24,5	114	97	19	8	M 8 x 20	933	A4-K80	4200	94	0,0044054	1,30
96	88	1730	140	21	3,5	24,5	120	102	19	8	M 8 x 20	933	A4-K80	4000	83	0,0051883	1,44
98	90	1900	140	21	3,5	24,5	120	102	19	8	M 8 x 20	933	A4-K80	4000	86	0,0050617	1,39
100	92	2140	145	21	3,5	24,5	124	107	19	8	M 8 x 20	933	A4-K80	3900	91	0,0059567	1,53
103	95	2310	145	21	3,5	24,5	124	107	19	8	M 8 x 20	933	A4-K80	3900	92	0,0057132	1,44
106	98	2160	150	21	3,5	24,5	128	112	19	8	M 8 x 20	933	A4-K80	3800	82	0,0065889	1,56
108	100	2340	150	21	3,5	24,5	128	112	19	8	M 8 x 20	933	A4-K80	3800	84	0,0064189	1,50
112	103	2340	160	25	4	29	134	119	19	8	M 8 x 20	933	A4-K80	3500	87	0,0102798	2,16
115	105	2540	160	25	4	29	134	119	19	8	M 8 x 20	933	A4-K80	3500	91	0,0099175	2,04
120	110	3030	169	25	4	29	140	124	19	8	M 8 x 20	933	A4-K80	3400	98	0,0106519	2,06
123	113	2910	169	25	4	29	144	129	19	8	M 8 x 20	933	A4-K80	3300	90	0,0121135	2,22
125	115	3160	169	25	4	29	144	129	19	8	M 8 x 20	933	A4-K80	3300	93	0,0117986	2,14
130	120	3370	174	25	4	29	150	134	19	12	M 8 x 20	933	A4-K80	3200	89	0,0130255	2,21
135	125	3810	179	25	4	29	154	139	19	12	M 8 x 20	933	A4-K80	3200	92	0,0143352	2,28
138	128	3600	184	25	4	29	160	144	19	9	M 8 x 20	933	A4-K80	3100	92	0,0161739	2,45
140	130	3700	184	25	4	29	160	144	19	9	M 8 x 20	933	A4-K80	3100	94	0,0157304	2,35

3173 1.4122 2-parts (stainless)

<i>d</i> mm	<i>d_w</i> mm	<i>M_{max}</i> Nm	<i>D</i> mm	<i>l</i> mm	<i>e</i> mm	<i>H</i> mm	<i>A</i> mm	<i>d₁</i> mm	<i>M_A</i> Nm	<i>Z</i> Pcs.	<i>S</i>	<i>DIN</i>	<i>Class</i>	<i>n_{max}</i> min ⁻¹	<i>p_N</i> N/mm ²	<i>I</i> kgm ²	<i>Weight</i> kg
145	135	4200	189	25	4	29	164	149	19	12	M 8 x 20	933	A4-K80	3000	87	0,0172140	2,43
150	140	4450	194	25	4,5	29,5	170	154	19	12	M 8 x 20	933	A4-K80	2900	89	0,0187885	2,50
160	150	4900	204	25	4,5	29,5	180	164	19	12	M 8 x 20	933	A4-K80	2800	68	0,0222215	2,64
166	156	5100	214	25	4,5	29,5	190	174	19	12	M 8 x 20	933	A4-K80	2600	66	0,0276174	3,01
170	160	5300	214	25	4,5	29,5	190	174	19	12	M 8 x 20	933	A4-K80	2600	65	0,0260512	2,79
182	170	8350	230	28	5	33	206	186	19	16	M 8 x 20	933	A4-K80	2400	57	0,0393299	3,66
202	190	9670	250	28	5	33	224	206	19	16	M 8 x 20	933	A4-K80	2200	51	0,0518157	4,01
232	220	15450	280	28	6	34	254	236	19	16	M 8 x 20	933	A4-K80	2000	56	0,0751252	4,55
242	230	15700	290	28	6	34	264	246	19	16	M 8 x 20	933	A4-K80	1900	50	0,0842232	4,72
262	250	17000	310	28	6,5	34,5	284	266	19	18	M 8 x 20	933	A4-K80	1800	45	0,1045710	5,08



TAS
SCHÄFER

3071 1.4122 3-parts (stainless)

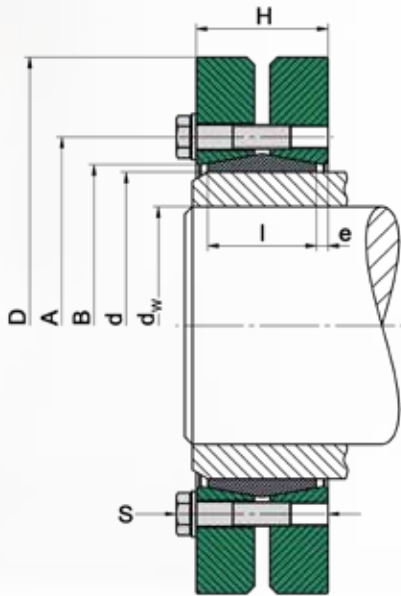

Used symbols

d	[mm]	Nominal diameter of the shrink disc
d _w	[mm]	Shaft diameter
M _{max}	[Nm]	Maximal transmittable torque
D	[mm]	Outer diameter
l	[mm]	Length of the inner ring
e	[mm]	Excess length
H	[mm]	Width of the shrink disc
A	[mm]	Pitch circle diameter
B	[mm]	Attachment size
M _A	[Nm]	Tightening torque of the clamping screws
Z		Number of clamping screws
S		Size of the clamping screws
n _{max}	[min ⁻¹]	Permitted rotational frequency
p _N	[N/mm ²]	Moderate pressure to the hub
I	[kgm ²]	Moment of inertia

Design of the shrink disc

d < 115	Without washers
d ≥ 115	With washers

Dimensions H & e in unlocked position

Hexagon head bolts are used as standard. Upon request we provide all sized shrink discs with hexagon socket head bolts (Inbus). (See ordering information)

Variation from the standard shaft diameter d_w

> mm	≤ mm	minimal - mm	maximal + mm
10	30	-1	1
30	50	-3	2
50	140	-5	5
140	180	-10	5
180	320	-15	10
320	500	-20	10
500	700	-30	20
700	820	-40	20

$$M = M_{\max(\text{Catalog})} \left(\frac{d_w(\text{target})}{d_w(\text{Catalog})} \right)^2$$

(see Basics - Calculation)

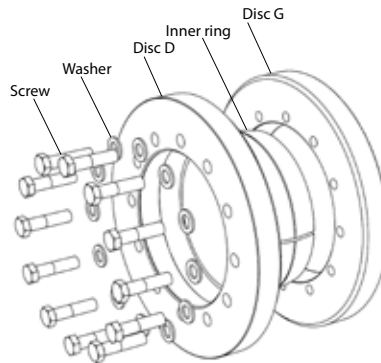

min. yield strength Rp0,2	N/mm ²
Solid shaft	240
Hub	290

Ordering information: TAS 3071 - d (z.B.: TAS 3071-200 1.4122 ... further sizes on request)
with Inbus: TAS 3071 - d - Inbus (z.B.: TAS 3071-200-Inbus 1.4122)

3071 1.4122 3-parts (stainless)

<i>d</i> mm	<i>d_w</i> mm	<i>M_{max}</i> Nm	<i>D</i> mm	<i>l</i> mm	<i>e</i> mm	<i>H</i> mm	<i>A</i> mm	<i>B</i> mm	<i>M_A</i> Nm	<i>Z</i> Stk	<i>S</i>	<i>DIN</i>	<i>Class</i>	<i>n_{max}</i> min ⁻¹	<i>P_N</i> N/mm ²	<i>I</i> kgm ²	<i>Weight</i> kg
14	11	24	37	9	1,5	12	24	15	2,4	3	M 4 x 10	933	A4-K80	15400	223	0,0000137	0,07
16	13	54	41	12	1,5	15	27	17	4,2	3	M 5 x 12	933	A4-K80	13900	213	0,0000266	0,11
18	15	74	43	12	1,5	15	29	19	3,3	4	M 5 x 12	933	A4-K80	13300	198	0,0000326	0,12
20	17	140	48	14	2,75	19,5	34	24	3,9	5	M 5 x 18	933	A4-K80	11900	226	0,0000642	0,19
21	18	160	48	14	2,75	19,5	34	24	3,9	5	M 5 x 18	933	A4-K80	11900	215	0,0000618	0,18
22	19	150	48	14	2,75	19,5	36	26	3,6	5	M 5 x 18	933	A4-K80	11900	190	0,0000627	0,18
24	20	160	50	14	2,5	19	36	26	3,3	6	M 5 x 18	933	A4-K80	11400	191	0,0000731	0,19
30	25	300	60	16	2,75	21,5	44	32	4,6	6	M 5 x 18	933	A4-K80	9500	187	0,0001687	0,30
36	30	440	72	18	2,75	23,5	52	38	8,2	5	M 6 x 20	933	A4-K80	7900	167	0,0003888	0,48
38	31	620	80	20	3	26	56	41	8,2	7	M 6 x 25	933	A4-K80	7100	199	0,0006569	0,67
40	32	500	75	19	2,75	24,5	57	43	8,2	6	M 6 x 20	933	A4-K80	7600	170	0,0004967	0,55
41	33	620	80	20	2,75	25,5	61	46	8	7	M 6 x 20	933	A4-K80	7100	180	0,0006465	0,64
44	35	640	80	20	2,75	25,5	61	47	8	7	M 6 x 20	933	A4-K80	7100	168	0,0006356	0,61
50	40	890	90	22	3	28	70	53	8,2	8	M 6 x 25	933	A4-K80	6300	157	0,0010998	0,83
55	45	1000	100	23	3,75	30,5	75	58	8,2	8	M 6 x 25	933	A4-K80	5700	137	0,0017909	1,1
62	50	1400	110	23	3,75	30,5	86	66	8,2	10	M 6 x 25	933	A4-K80	5200	151	0,0025909	1,3
68	55	1500	115	23	3,75	30,5	86	72	8,2	10	M 6 x 25	933	A4-K80	4900	138	0,0031236	1,4
75	60	2400	138	25	3,75	32,5	100	79	20	7	M 8 x 30	933	A4-K80	4100	162	0,0070923	2,3
80	65	2700	145	25	3,75	32,5	100	84	20	7	M 8 x 30	933	A4-K80	3900	152	0,0085703	2,5
90	70	4000	155	30	4,5	39	114	94	20	10	M 8 x 35	931	A4-K80	3600	161	0,0132516	3,3
100	75	4800	170	34	5	44	124	104	20	12	M 8 x 35	931	A4-K80	3300	154	0,0213950	4,4
110	80	5900	185	39	5,5	50	136	114	39,5	9	M 10 x 40	931	A4-K80	3000	145	0,0347437	6,0
115	80	6100	200	40	5	50	150	124	39,5	10	M 10 x 40	931	A4-K80	2800	150	0,0485678	7,3
120	85	10400	200	40	5	50	150	124	39,5	10	M 10 x 40	931	A4-K80	2800	144	0,0476000	7,0
125	90	8600	215	42	6	54	160	134	39,5	12	M 10 x 40	931	A4-K80	2600	158	0,0672619	8,7
140	100	11800	230	46	7,25	60,5	175	146	68	10	M 12 x 45	931	A4-K80	2400	157	0,0996875	11
155	110	15800	265	50	7,25	64,5	192	165	68	12	M 12 x 50	931	A4-K80	2100	156	0,1885000	16
165	120	25200	290	56	7,5	71	210	175	166	8	M 16 x 55	931	A4-K80	1900	175	0,3061438	22
175	130	27800	300	56	7,5	71	220	185	166	8	M 16 x 55	931	A4-K80	1900	165	0,3467969	23

W 1.4122 (stainless)

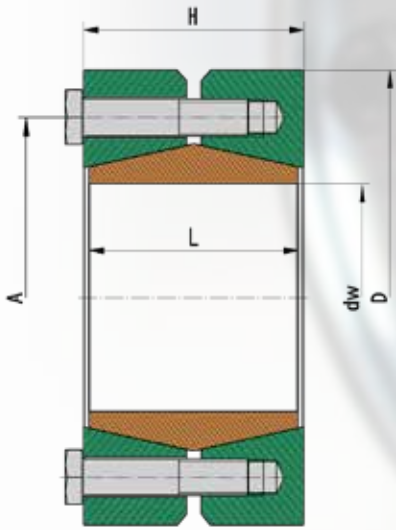

Used symbols

dw [mm]	Shaft diameter	
M_{max} [Nm]	max. transmittable torque	$F_{ax} = 0$
F_{ax} [kN]	max. transmittable axial force	$M_t = 0$
D [mm]	Outer diameter of coupling	
L [mm]	Length of sleeve	
H [mm]	Width of shaft coupling	
A [mm]	Pitch circle diameter of bolting	
M_A	Required tightening torque of clamping screws	
Z	Number of screws	
S	Size of screws	
p_w [N/mm ²]	Average contact pressure on the shaft	

Design of the disc

$d < 070$	Discs without washers
$d \geq 070$	Discs with washers

Dimensions H & e in unlocked position

Pos.	Designation
1	Sleeve
2	Pressure ring G
3	Pressure ring Dg
4	Screw

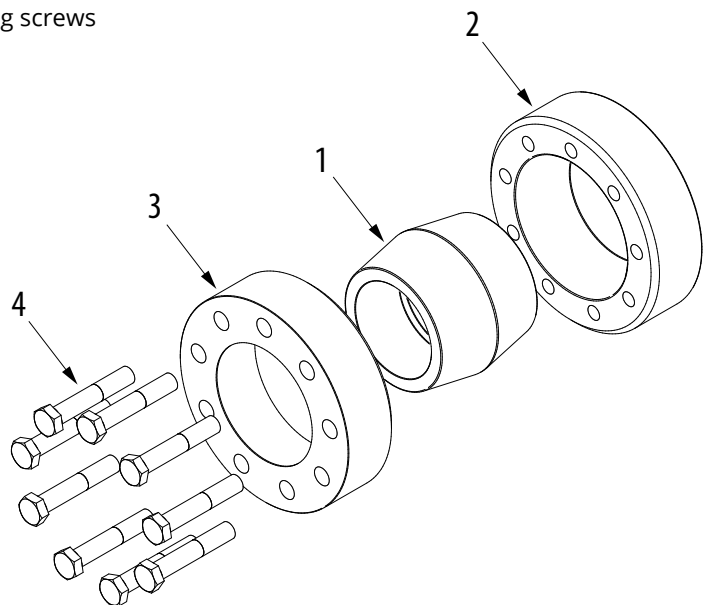

Ordering information: TAS W-Typ/d1/ d2 (e.g: TAS W070/065/070 1.4122 ...
further sizes on request)

W 1.4122 (stainless)

Type	d_w	M_{max}	F_{ax}	D	L	H	A	M_A	Z	S	DIN	Class	pw	Weight
mm	mm	Nm	kN	mm	mm	mm	mm	mm	Pcs.				N/mm ²	Kg
W015	15	75	10	55	30	33	37	5,8	7	M5 x 25	933	A4-K80	95	0,5
W015	17	137	16	55	30	33	37	5,8	7	M5 x 25	933	A4-K80	135	0,5
W020	18	105	12	60	34	37	42	7,5	8	M6 x 30	931	A4-K80	81	0,7
W020	20	155	16	60	34	37	42	7,4	8	M6 x 30	931	A4-K80	97	0,7
W020	22	241	22	60	34	37	42	7,4	8	M6 x 30	931	A4-K80	125	0,7
W025	23	250	22	66	38	41	48	9,3	8	M6 x 30	931	A4-K80	106	0,8
W025	25	355	28	66	38	41	48	9,4	8	M6 x 30	931	A4-K80	127	0,8
W025	27	475	35	66	38	41	48	9,4	8	M6 x 30	931	A4-K80	146	0,8
W030	28	435	31	76	42	45	54	8,2	10	M6 x 35	931	A4-K80	113	1,3
W030	30	562	37	76	42	45	54	8,2	10	M6 x 35	931	A4-K80	127	1,3
W030	32	667	42	76	42	45	54	8,2	10	M6 x 35	931	A4-K80	132	1,3
W035	33	510	31	80	46	49	62	8,2	12	M6 x 35	931	A4-K80	87	1,5
W035	35	660	38	80	46	49	62	8,2	12	M6 x 35	931	A4-K80	100	1,5
W035	37	820	44	80	46	49	62	8,2	12	M6 x 35	931	A4-K80	111	1,5
W040	38	810	43	98	50	54	71	20	8	M8 x 40	931	A4-K80	96	2,5
W040	40	985	49	98	50	54	71	20	8	M8 x 40	931	A4-K80	105	2,5
W040	43	1280	60	98	50	54	71	20	8	M8 x 40	931	A4-K80	118	2,5
W050	44	1440	65	115	60	64	86	39,5	8	M10 x 45	931	A4-K80	106	4
W050	50	2190	88	115	60	64	86	39,5	8	M10 x 45	931	A4-K80	124	4
W050	54	2700	100	115	60	64	86	39,5	8	M10 x 45	931	A4-K80	131	4
W060	55	2560	93	125	70	74	98	39,5	10	M10 x 50	931	A4-K80	103	5,3
W060	60	3420	114	125	70	74	98	39,5	10	M10 x 50	931	A4-K80	116	5,3
W060	64	4200	131	125	70	74	98	39,5	10	M10 x 50	931	A4-K80	125	5,3
W070	65	4110	126	148	80	85	112	39,5	12	M10 x 60	931	A4-K80	104	8,4
W070	70	5200	149	148	80	85	112	39,5	12	M10 x 60	931	A4-K80	113	8,4
W070	74	6170	167	148	80	85	112	39,5	12	M10 x 60	931	A4-K80	120	8,4
W080	75	6950	185	170	94	99	130	68	12	M12 x 70	931	A4-K80	112	13,1
W080	80	8400	210	170	94	99	130	68	12	M12 x 70	931	A4-K80	119	13,1
W080	84	9280	221	170	94	99	130	68	12	M12 x 70	931	A4-K80	119	13,1
W090	85	8550	201	185	104	109	145	166	7	M16 x 80	931	A4-K80	99	17
W090	90	10250	228	185	104	109	145	166	7	M16 x 80	931	A4-K80	106	17
W090	94	11730	250	185	104	109	145	166	7	M16 x 80	931	A4-K80	111	17
W100	95	13400	335	200	114	119	158	166	9	M16 x 90	931	A4-K80	113	21
W100	100	15580	312	200	114	119	158	166	9	M16 x 90	931	A4-K80	119	21
W100	104	17450	336	200	114	119	158	166	9	M16 x 90	931	A4-K80	123	21
W110	105	19700	375	217	124	129	170	156	12	M16 x 90	931	A4-K80	125	27
W110	110	22400	407	217	124	129	170	156	12	M16 x 90	931	A4-K80	129	27
W110	114	24750	434	217	124	129	170	156	12	M16 x 90	931	A4-K80	133	27
W120	115	25800	449	235	134	139	184	166	13	M16 x 90	931	A4-K80	126	33
W120	120	28960	483	235	134	139	184	166	13	M16 x 90	931	A4-K80	130	33
W120	124	31260	504	235	134	139	184	166	13	M16 x 90	931	A4-K80	131	33

W 1.4122 (stainless)

Type	d_w	M_{max}	F_{ax}	D	L	H	A	M_A	Z	S	DIN	Class	pw	Weight
mm	mm	Nm	kN	mm	mm	mm	mm	mm	Pcs.				N/mm ²	Kg
W130	125	32580	521	267	150	155	206	326	10	M20 x 110	931	A4-K80	123	45
W130	130	35770	550	267	150	155	206	326	10	M20 x 110	931	A4-K80	125	45
W130	134	39250	586	267	150	155	206	326	10	M20 x 110	931	A4-K80	129	45
W140	135	39350	583	280	160	165	218	326	11	M20 x 110	931	A4-K80	121	55
W140	140	43410	620	280	160	165	218	326	11	M20 x 110	931	A4-K80	124	55
W140	144	46820	650	280	160	165	218	326	11	M20 x 110	931	A4-K80	127	55
W150	145	47120	650	302	170	175	230	326	12	M20 x 120	931	A4-K80	118	70
W150	150	51560	687	302	170	175	230	326	12	M20 x 120	931	A4-K80	121	70



TAS
SCHÄFER

3012 S2 (stainless)

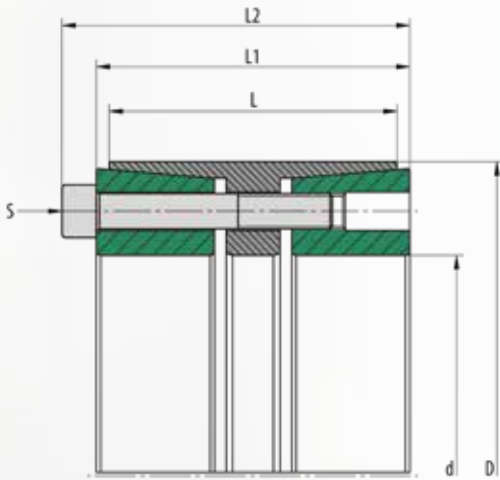

Used symbols

d	[mm]	Shaft diameter	
D	[mm]	Hub inside diameter	
M_t	[Nm]	Max. transmittable torque	$F_{ax} = 0$
F_{ax}	[kN]	Max. transmittable axial force	$M_t = 0$
p_w	[N/mm ²]	Average pressure on the shaft	
p_N	[N/mm ²]	Average pressure on the hub	
L	[mm]	Length of the sleeve	
L_1	[mm]	Width of the locking device without screws	
L_2	[mm]	Width of the locking device with screws	
Z		Number of clamping screws	
S		Size of the clamping screws	
M_A	[Nm]	Tightening torque of the clamping screws	

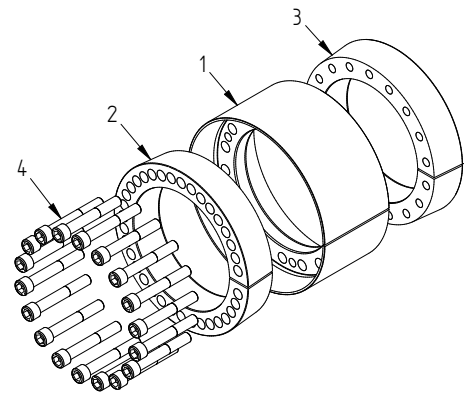

Recommended tolerances & surfaces

Shaft	h8 / Rz10
Hub	H8 / Rz10

Bending loads

Bending moment (share)	$M_B \max = 0,4 * M_t$
Bending angle	max. 5'

More properties

- low axial displacement during assembly
- very good self-centering
- high self-locking

Pos.	Benennung
1	Sleeve
2	Pressure ring 1
3	Pressure ring 2
4	Screw

Ordering information: TAS 3012/d/D S2 (z.B: TAS 3012/150/200 ... further sizes on request)

3012 S2 (stainless)

d mm	D mm	M_{max} Nm	F_{ax} kN	p_w N/mm ²	p_N N/mm ²	Z Pcs.	S	M_A Nm	L mm	L₁ mm	L₂ mm	Class	Weight Kg
25	x 50	415	33	95	39	5	M6 x 045	10,3	45	53	59	A4-K80	0,5
30	x 55	598	40	95	43	6	M6 x 045	10,3	45	55	61	A4-K80	0,6
35	x 60	814	46	95	46	7	M6 x 045	10,3	45	55	61	A4-K80	0,7
38	x 65	1009	53	100	48	8	M6 x 045	10,3	45	55	61	A4-K80	0,8
40	x 65	1063	53	95	48	8	M6 x 045	10,3	45	55	61	A4-K80	0,7
45	x 75	1926	86	148	69	7	M8 x 050	25	44	54	62	A4-K80	1,0
50	x 80	2446	98	118	58	8	M8 x 050	25	56	64	72	A4-K80	1,3
55	x 85	3026	110	121	61	9	M8 x 050	25	56	64	72	A4-K80	1,5
60	x 90	3668	122	123	64	10	M8 x 050	25	56	64	72	A4-K80	1,6
65	x 95	3974	122	113	61	10	M8 x 050	25	56	64	72	A4-K80	1,7
70	x 110	6813	195	132	67	10	M10 x 060	49,5	70	78	88	A4-K80	3,1
80	x 120	8565	214	127	68	11	M10 x 060	49,5	70	78	88	A4-K80	3,5
90	x 130	10512	234	123	68	12	M10 x 060	49,5	70	78	88	A4-K80	3,8
100	x 145	15607	312	118	63	11	M12 x 080	86	90	100	112	A4-K80	6,1
110	x 155	18729	341	117	65	12	M12 x 080	86	90	100	112	A4-K80	6,6
120	x 165	23836	397	125	71	14	M12 x 080	86	90	100	112	A4-K80	7,1
130	x 180	30378	467	114	66	12	M14 x 090	137	104	116	130	A4-K80	9,9
140	x 190	38167	545	123	73	14	M14 x 090	137	104	116	130	A4-K80	10,6
150	x 200	43814	584	123	75	15	M14 x 090	137	104	116	130	A4-K80	11,2
160	x 210	49851	623	123	76	16	M14 x 090	137	104	118	132	A4-K80	11,9
170	x 225	63589	748	106	66	14	M16 x 110	212	134	146	162	A4-K80	17,9
180	x 235	72139	802	107	68	15	M16 x 110	212	134	146	162	A4-K80	18,9
190	x 250	81223	855	109	68	16	M16 x 110	212	134	146	162	A4-K80	21,8
200	x 260	85498	855	103	65	16	M16 x 110	212	134	146	162	A4-K80	22,8
220	x 285	105804	962	105	67	18	M16 x 110	212	134	146	162	A4-K80	27,1
240	x 305	128248	1069	107	69	20	M16 x 110	212	134	146	162	A4-K80	29,3

3020 S2 (stainless)

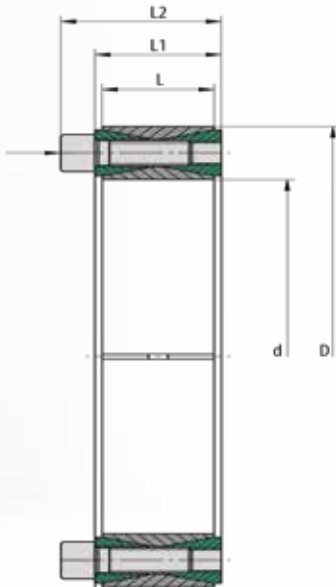

Used symbols

d	[mm]	Shaft diameter	
D	[mm]	Hub inside diameter	
M_t	[Nm]	Max. transmittable torque	$F_{ax} = 0$
F_{ax}	[kN]	Max. transmittable axial force	$M_t = 0$
p_w	[N/mm ²]	Average pressure on the shaft	
p_N	[N/mm ²]	Average pressure on the hub	
L	[mm]	Length of the sleeve inside and outside	
L_1	[mm]	Width of the locking device without screws	
L_2	[mm]	Width of the locking device with screws	
Z		Number of clamping screws	
S		Size of the clamping screws	
M_A	[Nm]	Tightening torque of the clamping screws	

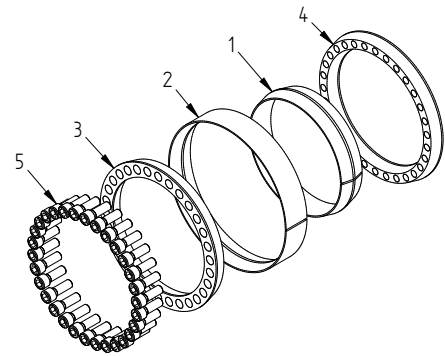

Recommended tolerances & surfaces

Shaft	from h11 to k11 / Rz10
Hub	from H11 to N11 / Rz10

Bending loads

Bending moment (share)	depending on hub
Bending angle	max. 2°

More properties

- no axial displacement during assembly
- no self-centering
- no self-locking

Pos.	Designation
1	Sleeve
2	Outer ring
3	Pressure ring 1
4	Pressure ring 2
5	Screw

Ordering information: TAS 3020/d/D S2 (z.B: TAS 3020/150/200 ... further sizes on request)

3020 S2 (stainless)

d mm	x	D mm	M_{max} Nm	F_{ax} kN	P_w N/mm ²	P_N N/mm ²	Z Pcs.	S	M_A Nm	L mm	L₁ mm	L₂ mm	Class	Weight kg
17	x	47	168	20	181	66	8	M6 x 018	10,3	17	20	27,5	A4-K80	0,23
18	x	47	178	20	171	66	8	M6 x 018	10,3	17	20	27,5	A4-K80	0,23
19	x	47	188	20	162	66	8	M6 x 018	10,3	17	20	27,5	A4-K80	0,23
20	x	47	198	20	154	66	8	M6 x 018	10,3	17	20	27,5	A4-K80	0,23
22	x	47	217	20	140	66	8	M6 x 018	10,3	17	20	27,5	A4-K80	0,23
24	x	50	237	20	129	62	9	M6 x 018	10,3	17	20	27,5	A4-K80	0,26
25	x	50	247	20	123	62	9	M6 x 018	10,3	17	20	27,5	A4-K80	0,25
28	x	55	415	30	165	84	10	M6 x 018	10,3	17	20	27,5	A4-K80	0,30
30	x	55	445	30	154	84	10	M6 x 018	10,3	17	20	27,5	A4-K80	0,29
32	x	60	474	30	145	77	12	M6 x 018	10,3	17	20	27,5	A4-K80	0,32
35	x	60	519	30	132	77	12	M6 x 018	10,3	17	20	27,5	A4-K80	0,32
38	x	65	704	37	152	89	14	M6 x 018	10,3	17	20	27,5	A4-K80	0,34
40	x	65	741	37	145	89	14	M6 x 018	10,3	17	20	27,5	A4-K80	0,34
42	x	75	1146	55	172	97	12	M8 x 022	25	20	24	33,5	A4-K80	0,57
45	x	75	1228	55	161	97	12	M8 x 022	25	20	24	33,5	A4-K80	0,57
48	x	80	1310	55	151	91	12	M8 x 022	25	20	24	33,5	A4-K80	0,60
50	x	80	1365	55	145	91	12	M8 x 022	25	20	24	33,5	A4-K80	0,60
55	x	85	1877	68	165	106	14	M8 x 022	25	20	24	33,5	A4-K80	0,63
60	x	90	2047	68	151	101	14	M8 x 022	25	20	24	33,5	A4-K80	0,69
65	x	95	2218	68	139	95	16	M8 x 022	25	20	24	33,5	A4-K80	0,73
70	x	110	3802	109	172	109	14	M10 x 025	49,5	24	28	39,5	A4-K80	1,26
75	x	115	4074	109	160	104	14	M10 x 025	49,5	24	28	39,5	A4-K80	1,33
80	x	120	4345	109	150	100	14	M10 x 025	49,5	24	28	39,5	A4-K80	1,40
85	x	125	4617	109	141	96	16	M10 x 025	49,5	24	28	39,5	A4-K80	1,49
90	x	130	4888	109	133	92	16	M10 x 025	49,5	24	28	39,5	A4-K80	1,53
95	x	135	6192	130	152	107	18	M10 x 025	49,5	24	28	39,5	A4-K80	1,62
100	x	145	7918	158	162	111	14	M12 x 030	86	26	33	47	A4-K80	2,01
110	x	155	8709	158	147	104	14	M12 x 030	86	26	33	47	A4-K80	2,15
120	x	165	10135	169	144	104	16	M12 x 030	86	26	33	47	A4-K80	2,35
130	x	180	13724	211	127	92	20	M12 x 035	86	34	38	52	A4-K80	3,51
140	x	190	16258	232	129	95	22	M12 x 035	86	34	38	52	A4-K80	3,85
150	x	200	19002	253	132	99	24	M12 x 035	86	34	38	52	A4-K80	4,07
160	x	210	21958	274	134	102	26	M12 x 035	86	34	38	52	A4-K80	4,03
170	x	225	27094	319	131	99	22	M14 x 040	137	38	44	60	A4-K80	5,78
180	x	235	31296	348	135	103	24	M14 x 040	137	38	44	60	A4-K80	6,05
190	x	250	38541	406	123	94	28	M14 x 045	137	46	52	68	A4-K80	8,25
200	x	260	43467	435	125	96	30	M14 x 045	137	46	52	68	A4-K80	8,65
220	x	285	56856	517	125	96	26	M16 x 050	212	50	56	74	A4-K80	11,22
240	x	305	71567	596	132	104	30	M16 x 050	212	50	56	74	A4-K80	12,20