



AC BRUSHLESS SERVOMOTORS - DSM5.0x



DSM5 - Size ZERO Brushless Servomotors are AC PM Synchronous servomotors. They have been designed using the latest generation of magnets and construction techniques to provide very high performance, low cogging and torque ripple. They can be supplied with resolver or Incremental / absolute encoder.

Their main characteristics are:

- Frame size 40mm
- Rare earth magnets for high performance
- 8 pole construction for high torque density
- Low cogging and torque ripple
- Sinusoidal back EMF
- Integrated PTC thermal protection
- Rotatable connectors
- Compact design
- High IP rating
- Smooth finish

Technical Data

Tab. 1

Description Winding code	Symbol	Motor	DSM5.04		DSM5.05	
		Units	1	3	1	3
Standstill Torque	M_0	Nm	0,19		0,38	
Maximum Torque	M_{pk}	Nm	0,6		1,3	
Standstill Current	I_0	A	0,78	1,55	1,21	3,0
Peak current	I_{pk}	A	3,1	6,1	4,8	12
Maximum mechanical revs	N_{mec}	min^{-1}	8500		8500	
Maximum revs @ 230Vac	N_{max}	min^{-1}	8000	-	8000	-
Maximum revs @ 50Vac	N_{max}	min^{-1}	-	3600	-	4100
Voltage constant	K_E	V/krpm	14,7	7,4	19	7,7
Torque constant	K_T	Nm/A	0,24	0,12	0,31	0,13
Rotor Inertia	J_R	$kg\ cm^2$	0,037		0,061	
Resistance @ 20°C	R_{U-V}	Ohm	27	6,8	14	2,4
Inductance @ 1 kHz	L_{U-V}	mH	11	2,6	7,9	1,25
Mass	m	kg	0,53		0,68	

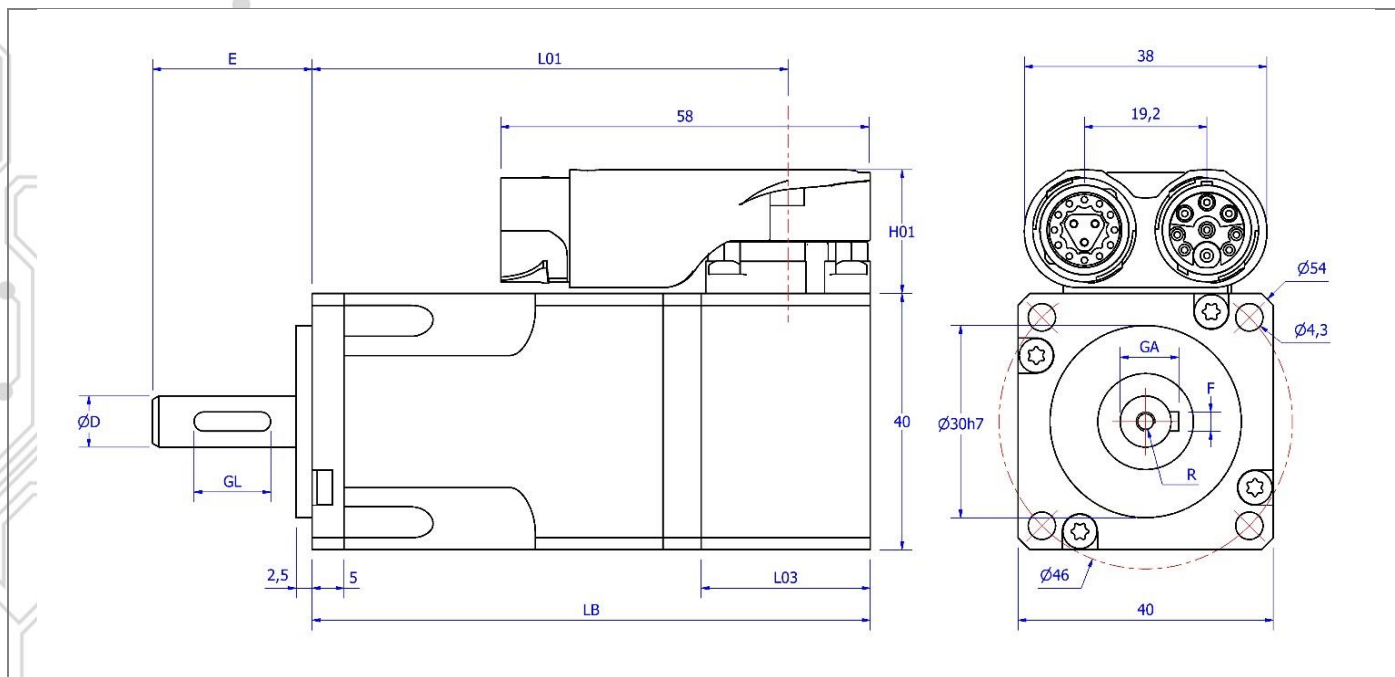

Dimension in mm

Tab. 2

Feedback device	EQI1131				TTL 1024ppr, Resolver				SKM36			
Dimension	LB	L01	L03	H01	LB	L01	L03	H01	LB	L01	L03	H01
DSM5.04	91	78	30	25,5	87,5	74,5	26,5	19,4	104	91	43	25,5
DSM5.05	109	96			105,5	92,5			122	109		
DSM5.04 Brake	123	110			119,5	106,5		25,5	136	123		
DSM5.05 Brake	141	128			137,5	124,5			154	141		

Dimension in mm

Tab. 3

Shaft	Dimension
D	8h6
E	25
GL	12
GA	9,2
F	3
R	M3 x 8

Values in this catalogue are true for the following conditions:

- Max ambient temperature 40° C
- Min ambient temperature 0 °C
- Max Altitude 1000 m (above sea level)
- Insulation class F (materials F & H)
- RMS values
- Insulation system conforms to UL
- IP65 enclosure protection (shaft IP64)
- Motor Installation B5 – V5
- Cooling IC410
- Typical tolerance value ±10%
- Continuous ratings apply with a rise of $\Delta T=100K$ on the windings when fitted on an aluminium plate with dimensions 254 x 254 x 8mm

Sangalli reserves the right to amend the specification of this product without prior notification.

PART NUMBER COMPOSITION

1	2	3	4	5	6	7	8	9	10	11	12
D	S	M	5	0	5	1	0	9	D	x	x

POS.	DESCRIPTION
------	-------------

1-3	Product DSM= PM synchronous motor, self-cooled
-----	--

4	Motor type Series 5
---	-------------------------------

5	Motor Size Size 0
---	-----------------------------

6	Motor length 4 = Mo 0,19 Nm 5 = Mo 0,38 Nm
---	---

7	Voltage 1 = Winding code 1 3 = Winding code 3
---	--

8	Holding brake 0 = No brake 1 = Permanent Magnet Brake 24V _{DC} 6W M _{br} =0,4Nm - J _{br} =0,02 kgcm ² m=200g 2 = Spring applied Brake 24V _{DC} 8W M _{br} =0,3Nm - J _{br} =1,14e-3 kgcm ² m=200g
---	---

9	Feedback 0 = Sensorless 3 = Heidenhain Encoder EQI1131 Endat Multi Turn 2.2 5 = Incremental Encoder 1024 PPR + hall or magnetic encoder 1024 ¹⁾ 9 = Resolver 2p 7V 10KHz C = Encoder Sangalli Servomotori ME29 Biss-C MT at battery cell W = Sick encoder EKS36 17bit NO SIL, DSL Y = Sick encoder EKM36 18bit Multi turn NO SIL, DSL
---	--

Available on request SIL option on some types of encoders

10	Connection type B = M15 ITEC single connector 9 poles D = M15 YTEC single connector 9p/12+3p
----	---

11-12	Special version <i>(Below some examples, for further details please contact our technical support.)</i>
-------	--

90 = Thermal protection PT1000
 xx = Special Shaft and Flanges (on request)

SANGALLI SERVOMOTORI



SANGALLI SERVOMOTORI S.r.l.

VIA FEDERICO ROSSI, 5
20900 - MONZA (MB) - ITALY

TEL. 1 : 00-39-039-2020322

TEL. 2 : 00-39-039-2020747

FAX : 00-39-039-2020656

INFO@SANGALLISERVOMOTORI.IT

WWW.SANGALLISERVOMOTORI.IT

MOTORS & MOTION CONTROL

- **DSM5 BRUSHLESS SERVOMOTORS**
- **DSG SYNCHRONOUS PM GENERATORS**
- **RARE EARTH SC DC SERVOMOTORS**
- **DSW WATER-COOLED**
- **LOW-COST SOLUTIONS**
- **PLANETARY GEARS**
- **CUSTOMISED SOLUTIONS**
- **TORQUE MOTORS**
- **FRAMELESS SPINDLE MOTORS**



ISD : E220486

