

**50 to 200 kN**  
KGT-S | translating screw

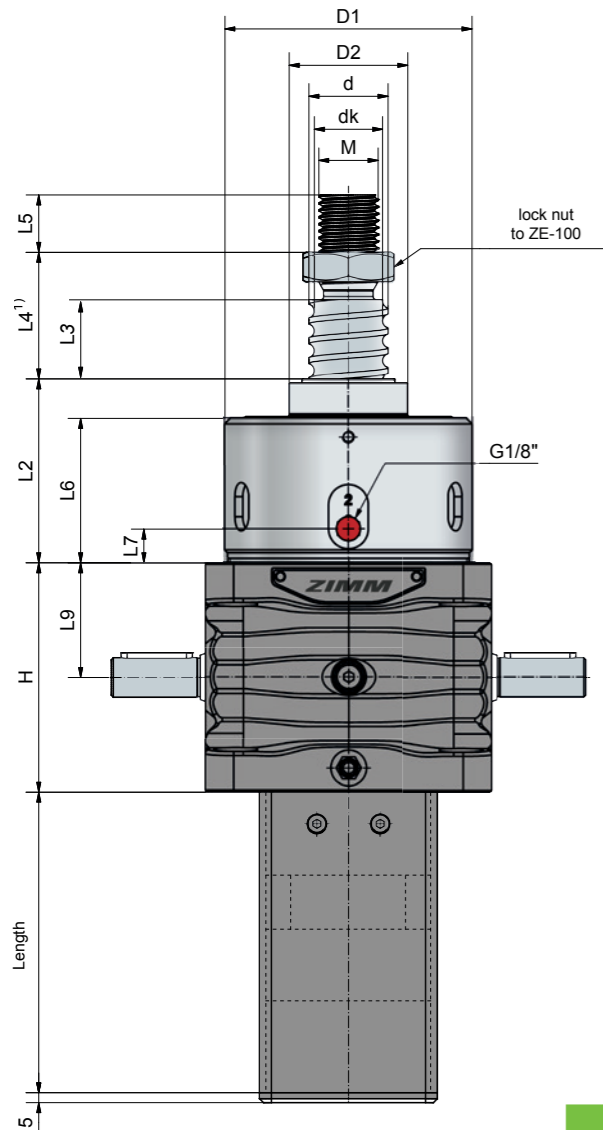

Screw jacks	KGT Screw ØxP	Stroke per drive revolution		KGT load rating kN		Axial play max <sup>4)</sup> mm
		SN	SL	dyn. C <sup>2)</sup>	stat. C <sub>0</sub> =C <sub>0a</sub>	
ZE-50	40x5	0,71	0,18	27,5	63,6	0,06
	40x10	1,43	0,36	46,1	71,3	0,06
	40x20	2,86	0,72	44	80,4	0,06
	40x40	5,71	1,43	35	101,9	0,06
ZE-100	50x10	1,11	0,28	122,4	248,6	0,06
	50x20	2,22	0,56	114,9	237,6	0,06
	50x40	4,44	1,11	110,7	273,9	0,03
ZE-150	63x10	1,11	0,28	150,2	598,4	0,03
	63x20	2,22	0,56	173,5 <sup>5)</sup>	346,2	0,03
	63x40	4,44	1,11	96,6	205,1	0,03
	63x60 <sup>3)</sup>	6,67	1,67	59,5	102,5	0,03
ZE-200	80x10 <sup>3)</sup>	1,25	0,42	206	710,8	0,03
	80x20	2,50	0,83	463,5	1163,7	0,03
	80x40	5,00	1,67	283,8	902	0,03
	80x60	7,50	2,50	193,6	582,5	0,03

# Technical data

## ZE-50-S

max. compressive/tensile force, static: 50 kN (5 t)  
 Input speed: 1500 rpm / max. 1800 rpm  
 Gearbox operating temperature: max. 60°C, higher on request  
 Moment of inertia: N: 2,85 kg cm<sup>2</sup> / L: 1,75 kg cm<sup>2</sup>  
 Input torque (at 1500 rpm): max. 31,5 Nm (N) / max. 10,4 Nm (L)  
 Drive-thorough torque: max. 260 Nm  
 Gear ratio: 7:1 (normal) / 28:1 (low-speed)  
 Housing material: GGG, corrosion-resistant  
 Worm shaft: steel, case-hardened, ground  
 Weight (screw jack): 23 kg

## ZE-100-S

max. compressive/tensile force, static: 100 kN (10 t)  
 Input speed: 1500 rpm / max. 1800 rpm  
 Gearbox operating temperature: max. 60°C, higher on request  
 Moment of inertia: N: 5,45 kg cm<sup>2</sup> / L: 3,43 kg cm<sup>2</sup>  
 Input torque (at 1500 rpm): max. 53,4 Nm (N) / max. 13,5 Nm (L)  
 Drive-thorough torque: max. 540 Nm  
 Gear ratio: 9:1 (normal) / 36:1 (low-speed)  
 Housing material: GGG, corrosion-resistant  
 Worm shaft: steel, case-hardened, ground  
 Weight (screw jack): 39 kg

## ZE-150-S

max. compressive/tensile force, static: 150 kN (15 t)  
 Input speed: 1500 rpm / max. 1800 rpm  
 Gearbox operating temperature: max. 60°C, higher on request  
 Moment of inertia: N: 7,92 kg cm<sup>2</sup> / L: 5,17 kg cm<sup>2</sup>  
 Input torque (at 1500 rpm): max. 75,1 Nm (N) / max. 20,7 Nm (L)  
 Drive-thorough torque: max. 540 Nm  
 Gear ratio: 9:1 (normal) / 36:1 (low-speed)  
 Housing material: GGG, corrosion-resistant  
 Worm shaft: steel, case-hardened, ground  
 Weight (screw jack): 42 kg

## ZE-200-S

max. compressive/tensile force, static: 200 kN (20 t)  
 Input speed: 1500 rpm / max. 1800 rpm  
 Gearbox operating temperature: max. 60°C, higher on request  
 Moment of inertia: N: 16,91 kg cm<sup>2</sup> / L: 8,59 kg cm<sup>2</sup>  
 Input torque (at 1500 rpm): max. 155 Nm (N) / max. 61 Nm (L)  
 Drive-thorough torque: max. 700 Nm  
 Gear ratio: 8:1 (normal) / 24:1 (low-speed)  
 Housing material: GGG, corrosion-resistant  
 Worm shaft: steel, case-hardened, ground  
 Weight (screw jack): 82 kg

A holding brake is necessary due to the lack of self-locking; either a brake motor or spring-loaded brake can be used.  
**Material:** 1.1213 (Cf 53), hardened inductiv and polished.

### Hint for high performance -Series ZE-H

For high duty cycles or input speed up to 3000 rpm please contact our sales department.

### Ordering example: ZE-50-SL-KGT 40x20, C = 44 kN

Version \_\_\_\_\_  
 SN or SL (translation) \_\_\_\_\_  
 KGT Screw \_\_\_\_\_  
 Dynamic load rating C \_\_\_\_\_

Screw jacks	KGT Screw ØxP	Dimensions mm														
		H	d	dk	D1	D2	L2	L3 <sup>1)</sup>	L4 <sup>1)</sup>	L5	L6	L7	L9	M		
ZE-50	40x5	116	39	36,4	125	60	93	15	39	29	74	17	58	M30		
	40x10	116	39	33,3	125	60	93	15	39	29	74	17	58	M30		
	40x20	116	39	34,3	125	60	93	30	54	29	74	17	58	M30		
	40x40	116	39	36,4	125	60	93	60	84	29	74	17	58	M30		
ZE-100	50x10	160	49	43,3	148	85	148	20	48	48	118	19	80	M36		
	50x20	160	49	43,3	148	85	148	40	68	48	118	19	80	M36		
	50x40	160	50	41,1	148	85	148	80	108	48	118	19	80	M36		
ZE-150	63x10	185	63	56,6	168	90	150	20	20	48	118	24	92,5	M42x2		
	63x20	185	63	51,8	168	90	150	40	40	48	118	24	92,5	M42x2		
	63x40	185	63	54,1	168	90	150	80	80	48	118	24	92,5	M42x2		
	63x60 <sup>3)</sup>	185	63	54,1	168	90	150	120	120	48	118	24	92,5	M42x2		
ZE-200	80x10 <sup>3)</sup>	176	79,4	74,36	214	110	226	20	20	58	192	128	88	M56x2		
	80x20	176	79,4	69,32	214	110	226	40	40	58	192	128	88	M56x2		
	80x40	176	79,4	72,68	214	110	226	80	80	58	192	128	88	M56x2		
	80x60	176	79,4	72,68	214	110	226	120	120	58	192	128	88	M56x2		

1) Depending on the control system and drive, the dimensions L3 and L4 can be reduced at your own discretion, in particular for high pitches. An extension may be required if a bellows or spiral spring extension is fitted.  
 2) Dynamic load rating to DIN 69051 part 4 draft 1989

3) Non-preferred design  
 4) Reduced play 0,02 mm available on request  
 5) Service life calculation with C<sub>dyn</sub> 159 kN (gearbox bearing)