

## Accessories

**Bellow FB** | Add-on component for translating and rotating version

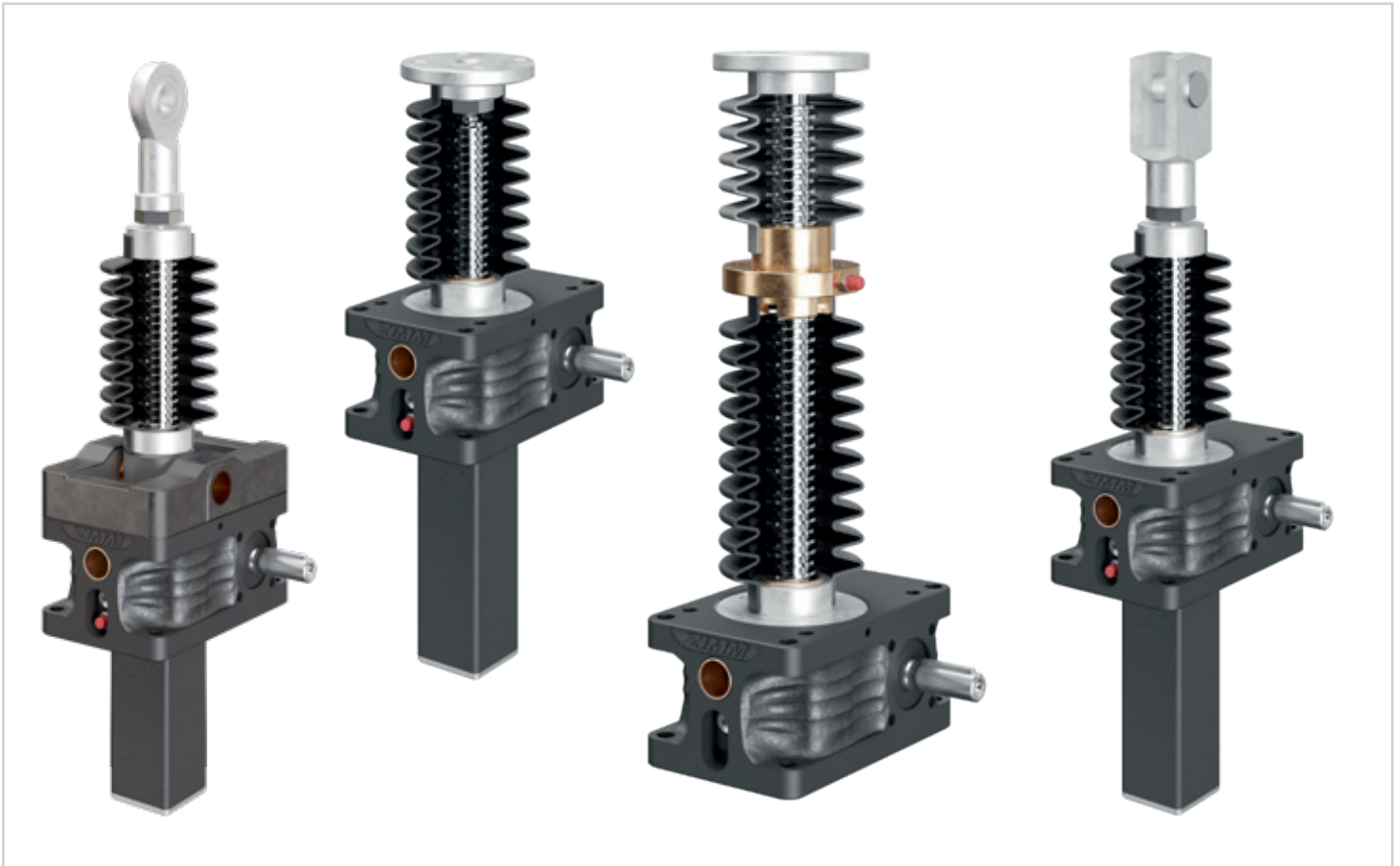

### The bellows protect the screw and lubricant against dirt and moisture

For optimum conditions use in conjunction with a bellow.

#### PLEASE NOTE:

The bellows must not be compressed to less than the ZD dimension nor extended beyond the AZ dimension. If the stroke is longer than 1000 mm, fit a bellows with an extension block. Take into consideration that when the bellows are fitted horizontally they must not touch the screw.

#### Risk of destruction!

This is prevented by using bellows with bushings.

A special installation to protect the spindle and bellows is required from: Concrete dust, grinding dust from angle grinders, welding spatter, etc. protect the bellows also from direct sunlight.

The maximum operating cycle of the lifting gear can be reduced by the heat-insulating effect of the bellows.



**Bellow FB, round**

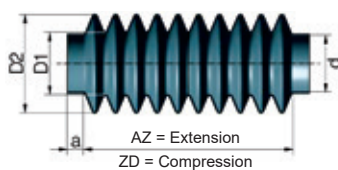

Code	a	d	ZD	AZ	Hub	D1	D2	kg
GSZ-2-FB-182	11	26	38	220	182	26	55	0,08
GSZ-2-FB-364	11	26	98	462	364	26	55	0,16
ZE-5-FB-265	12	29	35	300	265	40	76	0,2
ZE-10-FB-340	10	39	80	420	340	40	80	0,2
ZE-25-FB-300	15	50	70	370	300	50	83	0,3
ZE-35/50-FB-390	18	60	85	475	390	66	102	0,4
ZE-100-FB-285	15	85	75	360	285	85	118	0,3
ZE-150-FB-350	20	90	50	400	350	92	141	0,4
ZE-200-FB-390	15	110	90	480	390	110	160	0,8
Z-250-FB-390	15	120	90	480	390	125	166	1,1
Z-350-FB-600	15	145	100	700	600	172	236	2,4

Material: Thermoplast 99, PVC, operating temperature -20°C to +70°C (max. +85°C), cold fracture temperature -32°C, incl. 2 galvanised hose clips..

CAUTION: For screw extensions, see Sections 2+3

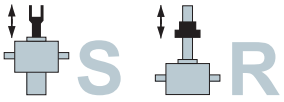

## Accessories

**Bellow FB** | Add-on component for translating and rotating version



**Bellows -FB, polygonal**

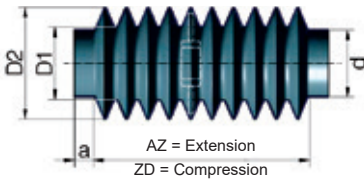

Material: Polyurethane-coated polyester fabric type, temperature stability  $-18^{\circ}\text{C}$  to  $+70^{\circ}\text{C}$ , UV and humidity resistant. When mounted horizontally, the bellows must be fitted with suitable support rings. For lengths longer than 1000 mm stroke, an extension block is necessary. Comes with 2 galvanised hose clips.

Code	a	d	ZD	AZ	Stroke	D1	D2	kg
ZE-5-FB-500	10	29	100	600	500	38	68	0,3
ZE-5-FB-800	10	29	120	920	800	38	68	0,5
ZE-10-FB-700	10	39	100	800	700	38	78	0,4
ZE-10-FB-1000	10	39	150	1150	1000	38	78	0,6
ZE-25-FB-700	15	46	100	800	700	65	105	0,5
ZE-25-FB-1000	15	46	120	1120	1000	65	105	0,7
ZE-35/50-FB-600	15	60	72	672	600	65	105	0,4
ZE-35/50-FB-1000	15	60	130	1130	1000	65	105	0,7
ZE-35/50-FB-1200	15	60	125	1325	1200	65	105	0,9
ZE-35/50-FB-1500	15	60	180	1680	1500	65	105	1,1
ZE-100-FB-600	15	85	72	672	600	70	110	0,4
ZE-100-FB-1000	15	85	130	1130	1000	70	110	0,7
ZE-100-FB-1500	15	85	180	1680	1500	70	110	1,1
ZE-150-FB-600	15	90	72	672	600	110	150	0,7
ZE-150-FB-1000	15	90	130	1130	1000	110	150	1,1
ZE-150-FB-1500	15	90	180	1680	1500	110	150	1,7
ZE-200-FB-600	15	110	72	672	600	110	150	0,7
ZE-200-FB-1000	15	110	130	1130	1000	110	150	1,1
Z-250-FB-600	15	120	72	672	600	110	150	0,4
Z-250-FB-1000	15	120	130	1130	1000	110	150	0,6
Z-250-FB-1500	15	120	180	1680	1500	110	150	0,82
Z-350-FB-900	15	145	108	1008	900	150	200	0,7
Z-350-FB-1500	15	145	180	1680	1500	150	200	1,1



**Bellows fixing ring FBR**

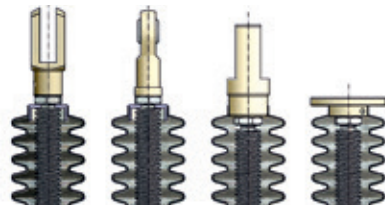

with with without without

The fixing ring FBR is used to secure the bellows FB to the forked end GK or rod end KGK. If a forked end GK or rod end KGK is included in the scope of the order, the fixing ring is supplied automatically. Otherwise, please order it separately.

Material: POM (plastic)

### Ordering example

ZE-25-FBR



**Bellows adapter FBA**

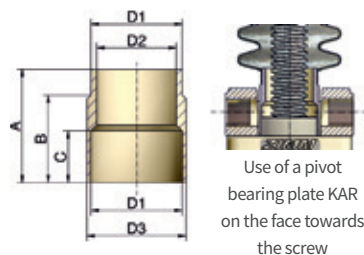

Code	D1	D2	D3	A	B	C
ZE-5-FBA	29	25	32	44	32	20
ZE-10-FBA	39	30	42	42	32	22
ZE-25-FBA	46	40	50	57	42	26
ZE-35/50-FBA	60	52	65	70	52	40
ZE-100-FBA	85	80	90	90	72	50
ZE-150-FBA	90	85	95	100	82	50

Material: Aluminium

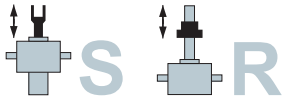

# Accessories

**Spiral spring SF** | Add-on component for translating and rotating version



**Spiral spring cover attachment for types SN/SL**

**Spiral spring cover attachment for types RN/RL**

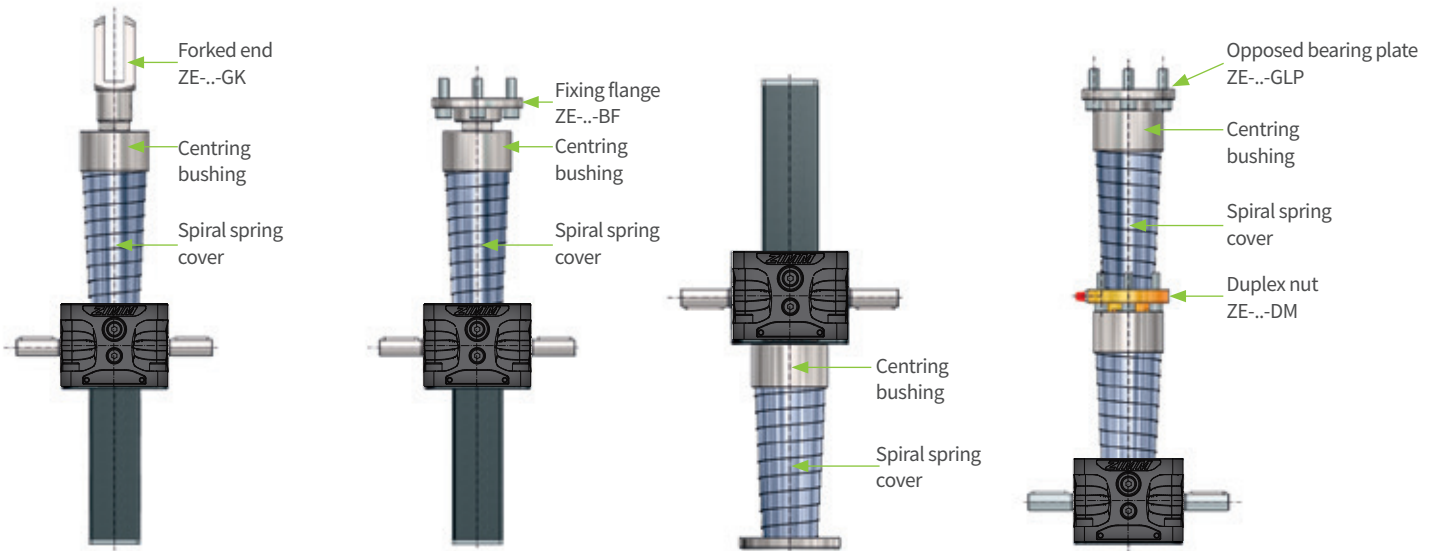

**Fitting instructions:**

The SF spiral spring is usually used when the use of a bellows is not possible. For example, when sharp-edged chips accumulate or if mechanical protection of the spindle is necessary. Centring bushings are required when assembling combinations of different parts; we can include these in our quotation on request.

**IMPORTANT!**

Spiral springs must under no circumstances be allowed to uncoil. For technical reasons, please specify in your enquiry whether the spiral spring is to be installed horizontally or vertically.

If installation is to be vertical, we recommend that the larger diameter is at the top, as shown; if it is to be horizontal, the taper should be away from the direction of flow of the chips or other particulate. As a result, the SF has a self-cleaning effect under normal conditions due to overlapping of the windings.

In the case of heavy soiling, regular cleaning is necessary to prevent malfunctions. A slight film of oil on the spiral spring improves its operation and extends its service life.

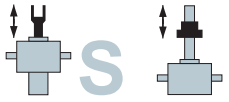

## Accessories

### Spiral spring SF | Cover for standing and rotating version

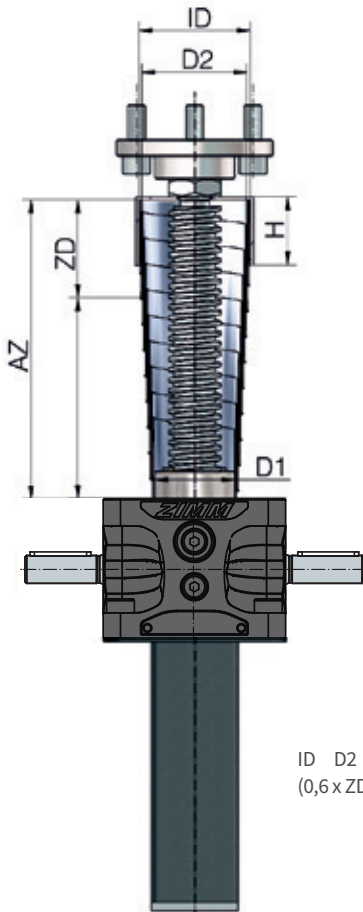

$$ID = D2 + 4 \text{ mm}$$

$$(0,6 \times ZD) \leq H \leq (ZD - 2 \text{ mm})$$

#### Technical data

**Spiral spring SF:** Spring band steel, blued  
(on request we can also supply versions in stainless steel)

**Centring bushing SFZ:** Plastic (other materials on request)

**CAUTION!:** The spring travel quoted is the maximum possible. For practical operation, please allow a margin of safety to prevent damage! We recommend preparation of a drawing to determine the fitting position and dimensions of spiral springs. Other sizes of spiral springs are available on request.

**Ordering example:** **SF-030-0450-030-H SFZ-ID57-H20**

Spiral spring \_\_\_\_\_  
 Least diameter D1 \_\_\_\_\_  
 Greatest length AZ\* \_\_\_\_\_  
 Least length ZD \_\_\_\_\_  
 H = horizontal installation \_\_\_\_\_  
 V = vertical installation \_\_\_\_\_  
 Centring bushing \_\_\_\_\_  
 Inner diameter \_\_\_\_\_  
 Height \_\_\_\_\_

\*For horizontal installation, this value is reduced by up to 1/3 depending on the size of the spiral spring. The max. stroke according to the table must be observed.

Size ZE-5 - SF (Screw jack)						Centring bushing SFZ		
Code	D1	D2	ZD	Stroke	kg	ID	AD	H
030-0450-030-V	30	53	30	420	0,3	57	61	20
030-0450-030-H	30	53	30	360	0,3	57	61	20

Size ZE-10 - SF (Screw jack)						Centring bushing SFZ		
Code	D1	D2	ZD	Stroke	kg	ID	AD	H
040-0450-040-V	40	64	40	410	0,53	69	73	30
040-0450-040-H	40	64	40	350	0,53	69	73	30
040-0900-060-V	40	70	60	840	1,09	74	78	36
040-0900-060-H	40	70	60	720	1,09	74	78	36
040-1300-075-V	40	84	75	1225	2,2	88	92	50
040-1300-075-H	40	84	75	1075	2,2	88	92	50

Size ZE-25 - SF (Screw jack)						Centring bushing SFZ		
Code	D1	D2	ZD	Stroke	kg	ID	AD	H
050-0450-050-V	50	70	50	400	0,64	74	78	36
050-0450-050-H	50	70	50	300	0,64	74	78	36
050-0750-060-V	50	80	60	690	1,07	84	88	40
050-0750-060-H	50	80	60	570	1,07	84	88	40
050-1200-075-V	50	94	75	1125	2,45	98	104	50
050-1200-075-H	50	94	75	975	2,45	98	104	50
050-1500-100-V	50	88	100	1400	2,7	92	96	60
050-1500-100-H	50	88	100	1300	2,7	92	96	60

Size ZE-35, ZE-50 - SF (Screw jack)						Centring bushing SFZ		
Code	D1	D2	ZD	Stroke	kg	ID	AD	H
065-0450-050-V	65	88	50	400	0,64	92	96	35
065-0450-050-H	65	88	50	300	0,64	92	96	35
065-1100-075-V	65	107	75	1025	2,5	112	118	60
065-1100-075-H	65	107	75	825	2,5	112	118	60
065-1500-100-V	65	108	100	1400	3,8	112	118	60
065-1500-100-H	65	108	100	1300	3,8	112	118	60
065-2100-120-V	65	113	120	1980	5,65	118	124	80
065-2100-120-H	65	113	120	1740	5,65	118	124	80

Size ZE-50/Tr50, ZE-100 - SF (Screw jack)						Centring bushing SFZ		
Code	D1	D2	ZD	Stroke	kg	ID	AD	H
090-0650-075-V	90	124	75	575	2,8	128	134	50
090-0650-075-H	90	124	75	425	2,8	128	134	50
090-1300-100-V	90	132	100	1200	4,9	136	142	60
090-1300-100-H	90	132	100	1000	4,9	136	142	60

ZE-50/Tr50 = increased screw (ZE-50-S with 50x8-Screw instead of 40x7).

Size ZE-150 - SF (Screw jack)						Centring bushing SFZ		
Code	D1	D2	ZD	Stroke	kg	ID	AD	H
100-0800-075-V	100	138	75	725	3,7	143	149	51
100-0800-075-H	100	138	75	575	3,7	143	149	51
100-1500-100-V	100	146	100	1400	6	150	156	75
100-1500-100-H	100	146	100	1200	6	150	156	75

#### CAUTION!

The spring travel quoted is the maximum possible. For practical operation, please allow a margin of safety to prevent damage! We recommend preparation of a drawing to determine the fitting position and dimensions of spiral springs. Other sizes of spiral springs are available on request.

# S R Pivot mounts LB 5 to 350 kN



Axis of pivoting **R**  
(at right angles to the drive)

## Pivot mounts LB (5 - 25)

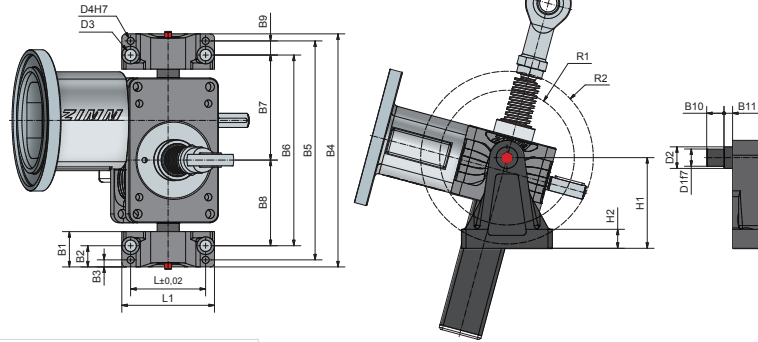

### Ordering example

ZE-5/10-LB Set (2 items) or ZE-25-LB Set (2 items)

### Lubrication

The bronze bushes are PTFE-coated and therefore require no lubrication in normal service. We recommend regular lubrication for high loadings.

Code	B1	B2	B3	B4	B5	B6	B7	B8	B9	B10	B11	D1	D2	D3	D4	H1	H2	L1	L2	R1	R2	kg/Set
ZE-5 (5/10-LB)	40	25	10	200	180	150	84	66	15	15	6	16	22	11	8	80	18	90	70	57	63	0,7
ZE-10 (5/10-LB)	40	25	10	220	200	170	95	75	15	15	6	16	22	11	8	80	18	90	70	68	74	0,7
ZE-25 (25-LB)	40	24	8	264	248	216	119	97	16	20	10	20	25	13	8	105	21	105	85	78	100	1,3

Material: aluminium, corrosion-resistant, bolt: stainless steel



Axis of pivoting **P**  
(parallel to the drive)

## Bearing mount LB (35 - 350)

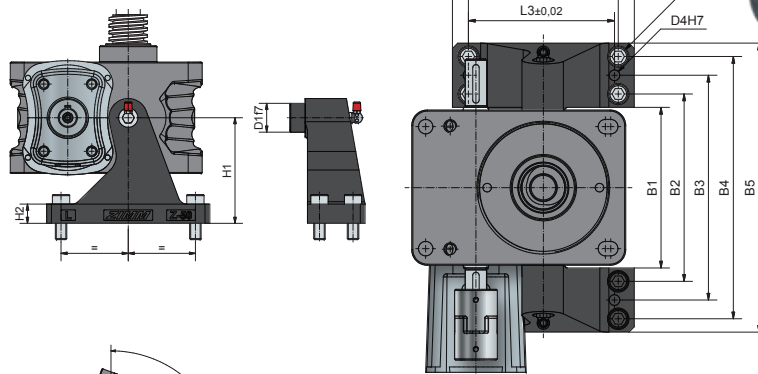

### Lubrication

The bronze bushings in the gearbox are PTFE-coated and therefore do not need to be lubricated during normal operation. For heavy loads we recommend regular lubrication.

### Ordering example

ZE-50-LB Set (2 items)

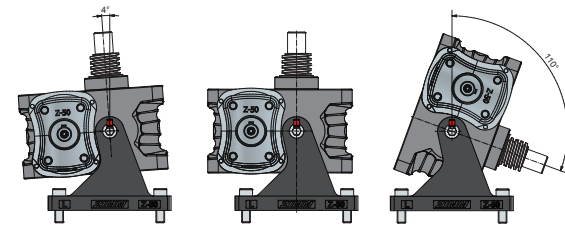

Code	D1	D3	D4	H1	H2	L1	L2	L3	B1	B2	B3	B4	B5	kg/Set
ZE-35-LB	28	11	8	85	18	130	106	106	124	146	174	202	224	3,2
ZE-50-LB	30	13	10	110	18	170	140	140	150	175	210	245	270	5
ZE-100-LB	40	22	20	120	22	260	180	225	210	250	290	330	370	11,8
ZE-150-LB	50	22	20	135	24	280	200	235	222	262	312	362	402	18
ZE-200-LB*	50	22	20	135	24	280	200	235	237	277	327	377	417	18
Z-250-LB	60	26	20	170	32	285	230	220	265	325	400	475	535	31
Z-350-LB	80	33	25	210	36	380	310	300	302	372	462	552	622	66

Material: cast steel, tempered, corrosion-resistant

\*ZE-150-LB is used for the ZE-200-LB. Max. load capacity: 150 kN



# S R Pivot bearing plate KAR



Axis of pivoting **P**  
 (parallel to the drive)

Pivot bearing plate KAR

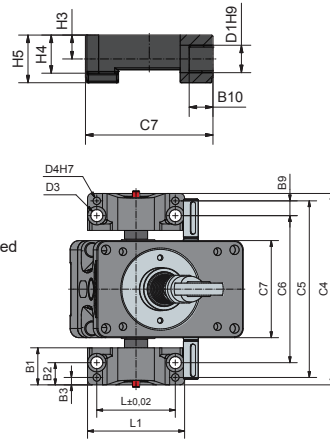
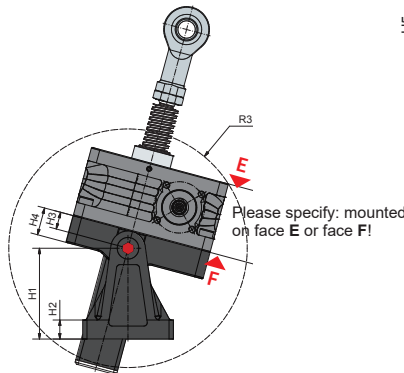

**Lubrication**

The bronze bushings in the gearbox are PTFE-coated and therefore do not need to be lubricated during normal operation. For heavy loads we recommend regular lubrication.

For large motors, long strokes and a high operating cycle, the variant with the slide bearing plate KAR is to be preferred because then the motor weight is absorbed by the pivot bearing plate and does not affect the spindle.

Code	B1	B2	B3	B9	B10	C4	C5	C6	C7	D1	D3	D4	H1	H2	H3	H4	H5	L1	L2	R3	kg
ZE-5-KAR	40	25	10	15	15	166	146	116	74	16	11	8	80	18	15	21	30	90	70	100	0,2
ZE-10-KAR	40	25	10	15	15	179	159	129	87	16	11	8	80	18	15	24	30	90	70	116	0,3
ZE-25-KAR	40	24	8	16	20	207	191	159	107	20	13	8	105	21	20	32	40	105	85	138	0,8

Material: aluminium, corrosion-resistant Other sizes of pivot arrangements **R** and **P** are available on request.



Axis of pivoting **R**  
 (at right angles to drive)

Pivot bearing plate ZE-35-KAR

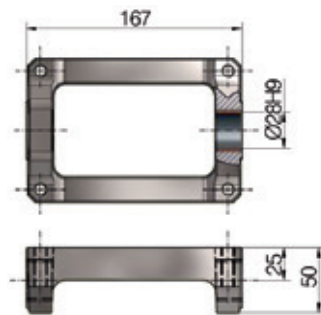

**Multiple system control**  
 With the pivot bearing plate KAR you can control and connect a setup of multiple gearboxes lined up in a row.



Pivot bearing plate GSZ-KAR (2 to 150)

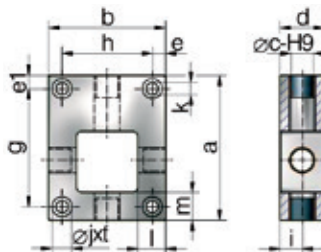

Code	a	b	c	d	e	e1	g	h	i	j	k	l	m	t	kg
GSZ-2-KAR <sup>1)</sup>	70	50	16	30	6	6	48	38	13	13	6,6	11	13	8	0,16
GSZ-5-KAR	80	72 <sup>2)</sup>	16	30	10	10	60	52	15	15	9	18	10	9	0,8
GSZ-10-KAR	100	85 <sup>2)</sup>	16	30	11	11	78	63	15	15	9	16	11	9	1,15
GSZ-25-KAR	130	105 <sup>2)</sup>	20	40	12	12	106	81	20	18	11	25	25	11	2,8
GSZ-50-KAR	180	145	30	50	15	15	150	115	25	20	13	24	30	13	5,3
GSZ-100-KAR	200	175	40	70	22	17	166	131	35	26	17	40	30	18	11,1
GSZ-150-KAR	220	205	50	80	25	25	170	155	40	33	22	40	28	22	13,47

Material: steel, corrosion-resistant. 1) GSZ-2-KAR: aluminium, corrosion-resistant. Delivery incl. screws.

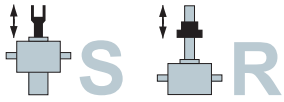

# Accessories

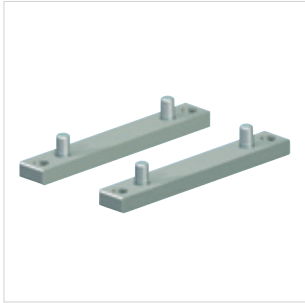

**Fixing strips BFL**

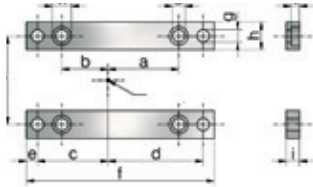

Code	a	b	c	d	e	f	g	h	i	j	k	l	kg
GSZ-2-BFL	32	16	29,5	45,5	7,5	90	6,6	14	10	38	11	6,4	0,16
GSZ-5-BFL	39	21	41	59	10	120	9	20	10	52	14	6	0,32
GSZ-10-BFL	49	29	50	70	10	140	9	20	14	63	14	6	0,5
GSZ-25-BFL	64	42	64	86	10	170	11	25	12	81	17	7,5	0,75
GSZ-50-BFL	87	63	90	114	13	230	13	30	20	115	19	7	2
GSZ-100-BFL	100	66	101	135	17	270	18	40	25	131	26	11	3,7
GSZ-150-BFL	100	70	115	145	20	300	22	50	35	155	33	13	6,75

Material: steel, corrosion-resistant / GSZ-2-BFL: stainless steel  
 Delivery incl. screws



**Handwheel HR**

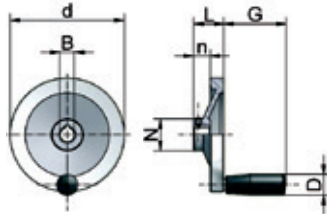

Code	d	N	b	n	L	G	D	B H7 pilot hole	B H7 with nut	kg
HR-080	80	26	13	16	26	42,5	18	8	9/11	0,16
HR-125	125	31	15	18	33	67,5	23	6	11/14	0,3
HR-160	160	36	18	20	39	82,5	26	6	14/16/19	0,5
HR-200	200	42	20,5	24	45	82,5	26	16	16/19/20	1
HR-250	250	48	23	28	51	92,5	28	22	20/25	1,3

Material: Aluminium, plastic (handle)  
 Design: No more than max. 50 - 60 N force should be required at the handle.

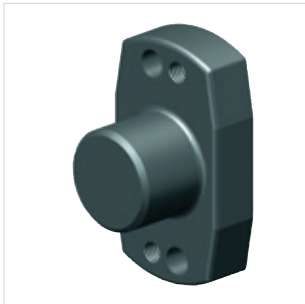

**Protective cap GSZ-2-SK**

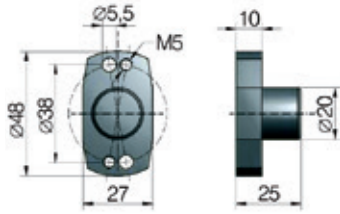

Code	D	d	E	F	Screws DIN 912	kg
GSZ-2-SK	20	5,5/M5	25	10	M5x55	0,05

Incl. screws  
 Material: hard anodised aluminium.

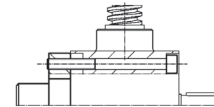

**M5x55**  
 Screws are included with the protective cap

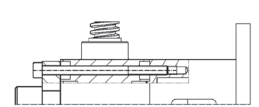

**M5x77**  
 Screws are included with the motor flange / bevel gearbox



**Protective cap SK**

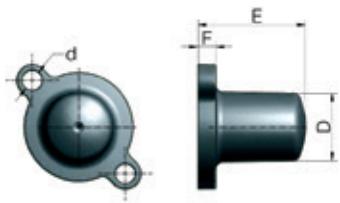

incl. screws

Code	D	d	E	F	Screws DIN 912	kg
ZE-5-SK	25	7	32	8	M6x16	0,02
ZE-10-SK	30	9	32	8	M8x16	0,04
ZE-25-SK	31	9	49	8	M8x16	0,05
ZE-35-SK	35	11	54	8	M10x20	0,07
ZE-50-SK	35	11	55	8	M10x20	0,08
ZE-100/150-SK	46	13,5	74	8	M12x25	0,13
ZE-200-SK	60	17,5	82	25	M16x25	0,50
Z-250-SK	60	17,5	82	25	M16x30	0,7
Z-350-SK	75	20	85	30	M18x30	0,9
Z-500-SK	90	22	125	35	M20x40	1,2
Z-750-SK	110	22	122	28	M20x40	1,5
Z-1000-SK	100	26	142	30	M24x40	2,2

Incl. screws  
 Material: ZE-5 to ZE-200: PA6 GF15, up to 120°C, briefly 180°C.  
 Material: Z-250 to Z-1000: POM, up to 100°C, briefly 140°C.

Suitable for screw jacks ZE, Z, GSZ and KSZ-H bevel gearbox (see chapter 5).

**CAUTION**  
 For bevel gearboxes, the protective cap must be the same size as the motor flange.

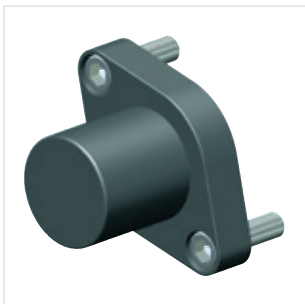

ZE-200 to Z-1000

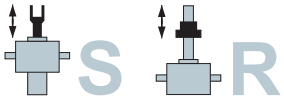

# Accessories

## Motor flange MF | GSZ-2, ZE-5 to ZE-25

### Motor flange MF - GSZ-2

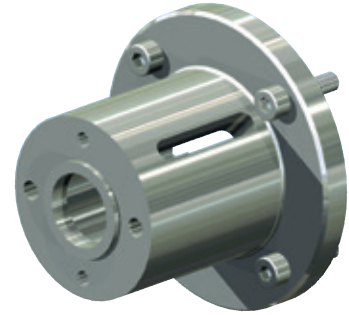
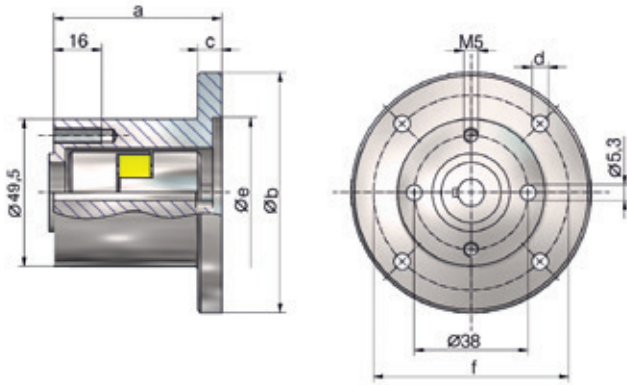

Code	Motor type	Coupling Code Bore - Ø			2 screws gearbox side 8.8	4 screws motor side 8.8 DIN 912 for motor incl. spring washers	a	Øb	c	Ød	Øe	Øf	kg
		Size	Gearbox	Motor									
GSZ-2-MF-80-51 <sup>2)</sup>	56 B14C	KUZ-09	9	9	M5x55, M5x70	M5x20	51	80	9	5,5	50	65	0,22
GSZ-2-MF-80-41+P-120-15 <sup>3)</sup>	63 B14B	KUZ-14	9	11	M5x55, M5x70, M5x45	M6x25	56	120	15	6,6	80	100	0,55
GSZ-2-MF-80-51+P-105-15 <sup>2)</sup>	71 B14C	KUZ-14	9	14	M5x55, M5x70	M6x20	66	105	15	6,6	70	85	0,45

Material: hard anodised aluminium. Delivery incl. screws

1) Screws are included for all the various fitting options

2) For LB parallel to the drive axis, restricted pivot bearing range

3) LB parallel to drive axis not possible

### Motor flange MF

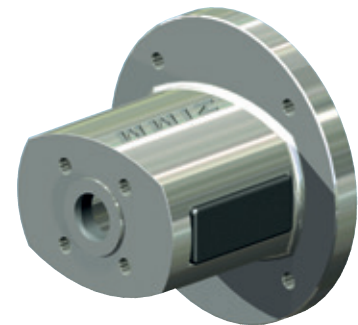
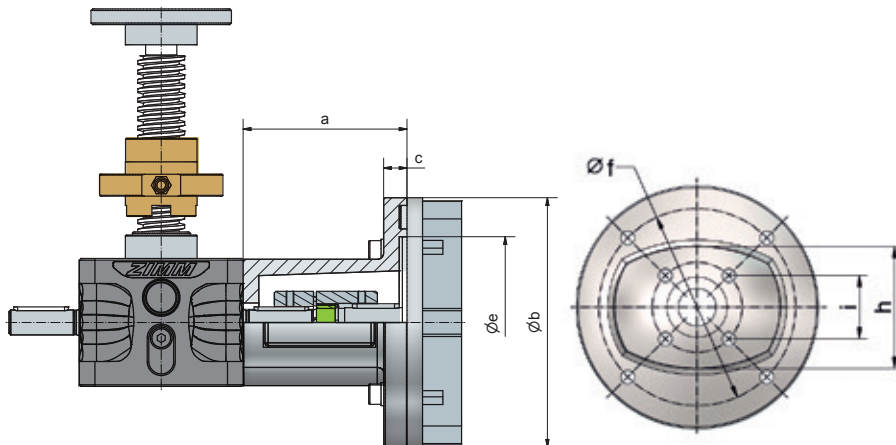

Code	Motor type	Coupling code Bore - Ø			4 screws gearbox side 8.8	4 of socket head cap 8.8 DIN 912 for motor	a	b	c	e	f	h	i	kg
		Size	Gearbox	Motor										
ZE-5-MF-120-60	63 B14B	KUZ-14	11	11	M6x12 - DIN 7991	M6x20 + spring washers	60	120	10	80	100	61	32,5	0,3
ZE-5-MF-105-68	71 B14C	KUZ-19	11	14	M6x12 - DIN 7991	M6x20 + spring washers	68	105	10	70	85	61	32,5	0,3
ZE-10-MF-120-66	63 B14B	KUZ-19	14	11	M8x16 - DIN 7991	M6x20 + spring washers	66	120	10	80	100	73	35,4	0,4
ZE-10-MF-160-75	71 B5	KUZ-19	14	14	M8x16 - DIN 7991	M8x35 + nuts	75	160	15	110	130	73	35,4	0,8
ZE-10-MF-160-90	80 B14B	KUZ-24	14	19	M8x16 - DIN 7991	M8x30 + spring washers	90	160	15	110	130	73	35,4	0,8
ZE-25-MF-160-105	71 B5	KUZ-28	16	14	M8x20 - DIN 7991	M8x35 + nuts	105	160	15	110	130	81	42	1,1
ZE-25-MF-160-105	80 B14B	KUZ-24	16	19	M8x20 - DIN 7991	M8x30 + spring washers	105	160	15	110	130	81	42	1,1
ZE-25-MF-160-105	90 B14B	KUZ-24	16	24	M8x20 - DIN 7991	M8x30 + spring washers	105	160	15	110	130	81	42	1,1
ZE-25-MF-160-122	100 B14C	KUZ-28	16	28	M8x20 - DIN 7991	M8x30 + nuts	122	160	15	110	130	81	42	1,2

Material: Aluminium, all screws galvanized nut DIN 934 and spring washers DIN 128. Delivery incl. screws



**S R Accessories**  
**Motor flange MF | ZE-35 to ZE-200**

**Motor flange MF**

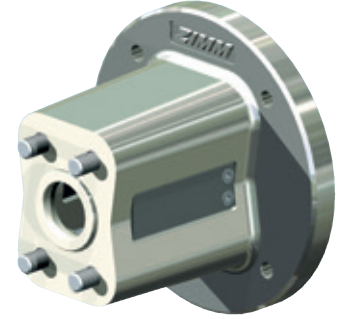
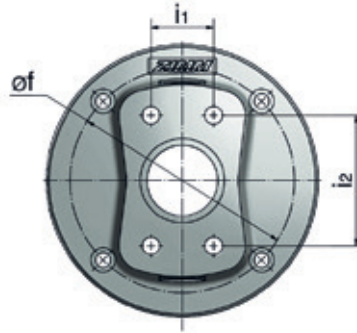
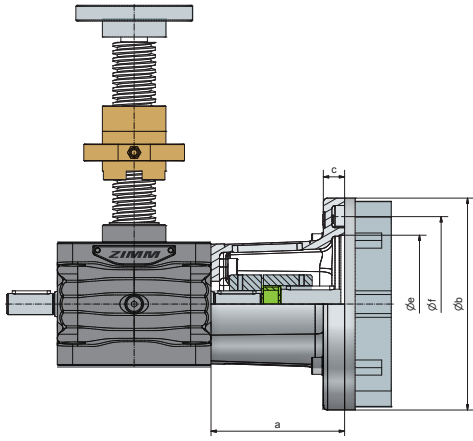

**Motor flange base MF-B and motor flange plate MF-P - ZE-35 to ZE-200**

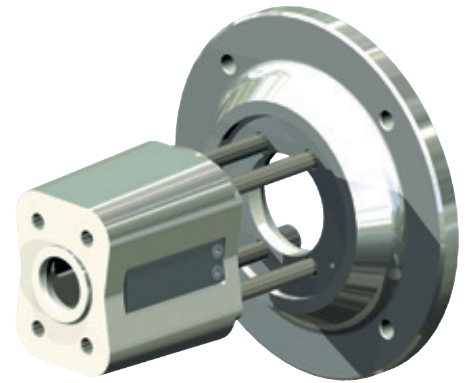
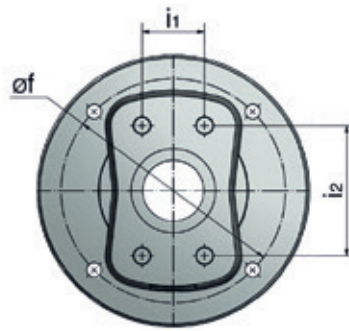
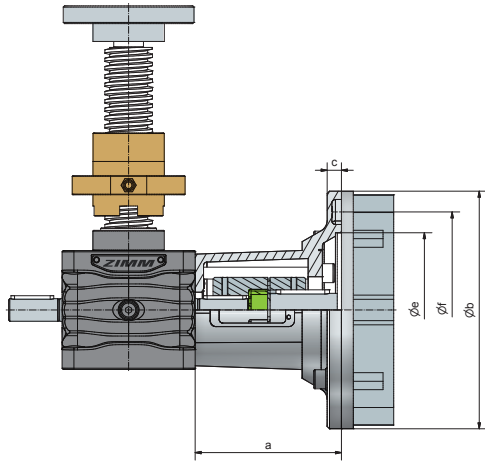

Code	Motor type	Coupling code			4 screws gearbox side DIN 912	4 screws motor side DIN 912	a	b	c	e	f	i1	i2	kg
		Size	Gearbox	Motor										
ZE-35-MF-160-111	80 B14B	KUZ-24	19	19	M10x30	M8x25 <sup>1)</sup>	111	160	15	110	130	36	62	2,7
ZE-35-MF-160-111	90 B14B	KUZ-24	19	24	M10x30	M8x25 <sup>1)</sup>	111	160	15	110	130	36	62	2,7
ZE-35-MF-B + ZE-35-MF-P-200	100 B14B	KUZ-28	19	28	M10x120	M10x30 <sup>1)</sup>	123	200	12	130	165	36	62	3,6
ZE-35-MF-B + ZE-35-MF-P-200	112 B14B	KUZ-28	19	28	M10x120	M10x30 <sup>1)</sup>	123	200	12	130	165	36	62	3,6
ZE-35-MF-B + special plate	Servomotors, geared motors, Nema, ...													
ZE-50-MF-200-116	90 B5	KUZ-28	20	24	M10x30	M10x45 <sup>2)</sup>	116	200	20	130	165	50	70	4,1
ZE-50-MF-200-126	100 B14B	KUZ-28	20	28	M10x30	M10x35 <sup>1)</sup>	126	200	20	130	165	50	70	4,3
ZE-50-MF-200-126	112 B14B	KUZ-28	20	28	M10x30	M10x35 <sup>1)</sup>	126	200	20	130	165	50	70	4,3
ZE-50-MF-B + special plate	Servomotors, geared motors, Nema, ...													
ZE-100/150-MF-200-138	100 B14B	KUZ-28	25	28	M12x40 <sup>3)</sup>	M10x35 <sup>1)</sup>	138 <sup>3)</sup>	200	20	130	165	46	96	5,3
ZE-100/150-MF-200-138	112 B14B	KUZ-28	25	28	M12x40 <sup>3)</sup>	M10x35 <sup>1)</sup>	138 <sup>3)</sup>	200	20	130	165	46	96	5,3
ZE-100/150-MF-B + P-200	132 B14C	KUZ-38	25	38	M12x150 <sup>3)</sup>	M10x65 <sup>1)</sup>	161 <sup>3)</sup>	200	48	130	165	46	96	8,7
ZE-100/150-MF-B + special plate	Servomotors, geared motors, Nema, ...													
ZE-200-MF-200-168	100 B14B	KUZ-38	28	28L	M16x45	M10x40 <sup>1)</sup>	168	200	20	130	165	56	100	8,1
ZE-200-MF-200-168	112 B14B	KUZ-38	28	28L	M16x45	M10x40 <sup>1)</sup>	168	200	20	130	165	56	100	8,1
ZE-200-MF-200-168	132 B14C	KUZ-38	28	38	M16x45	M10x40 <sup>1)</sup>	168	200	20	130	165	56	100	8,1
ZE-200-MF-200-168 + P-350	160 B5	KUZ-45	28A	42	M16x45	M16x70 <sup>2)</sup>	198	350	30	250	300	56	100	24,8
ZE-200-MF-200-168 + special plate	Servomotors, geared motors, Nema, ...													

Material: GGG-50, corrosion-resistant, all screws galvanized nut DIN 934 and spring washers DIN 128. Delivery incl. Screws.

1) incl. spring washers

2) incl. nuts and spring washers

3) Threaded bolt 8.8 with nuts and spring washers



# Accessories

## Motor flange MF | Z-250 to Z-1000

### Motor flange MF



### Motor flange base MF-B and motor flange plate MF-P - Z-350 to Z-500

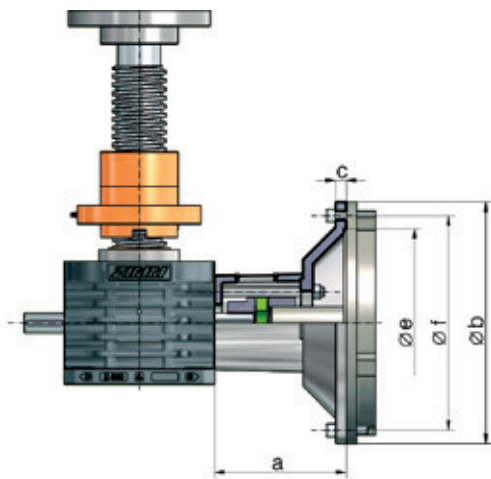

Code	Motor type	Coupling code Bore - Ø			4 screws gearbox side DIN 912	4 screws motor side DIN 912	a	b	c	e	f	kg
		Size	Gearbox	Motor								
Z-250-MF-200-168	100 B14B	KUZ-38	28L	28L	M16x55	M10x40 <sup>1)</sup>	168	200	20	130	165	8,5
Z-250-MF-200-168	112 B14B	KUZ-38	28L	28L	M16x55	M10x40 <sup>1)</sup>	168	200	20	130	165	8,5
Z-250-MF-200-168	132 B14C	KUZ-38	28	38	M16x55	M10x40 <sup>1)</sup>	168	200	20	130	165	8,5
Z-250-MF-200-168 + P-350	160 B5	KUZ-45	28A	42	M16x55	M16x70 <sup>2)</sup>	198	350	30	250	300	20,5
Z-250-MF-200-168 + P-350	180 B5	KUZ-55	28A	48	M16x55	M16x70 <sup>2)</sup>	198	350	30	250	300	20,5
Z-250-MF-200-168 + P-400	200 B5	KUZ-55	28A	55	M16x55	M16x70 <sup>2)</sup>	200	400	32	300	350	25
Z-250-MF-200-168 + special plate	Servomotors, geared motors, Nema,...											
Z-350-MF-B + P-350	180 B5	KUZ-55	38A	48	4x M18x230	M16x60 <sup>2)</sup>	211	350	19	250	300	24
Z-350-MF-B + P-400	200 B5	KUZ-55	38A	55	4x M18x230	M16x60 <sup>2)</sup>	211	400	19	300	350	27
Z-350-MF-B + P-450	225 B5	KUZ-60	38A	60	4x M18x230	8x M16x60 <sup>2)</sup>	243	450	19	350	400	33
Z-350-MF-B + special plate	Servomotors, geared motors, Nema,...											
Z-500-MF-SO	Dimensions on request											
Z-750-MFSO	Dimensions on request											
Z-500-MF-B + special plate	Dimensions on request - Servomotors, geared motors, Nema,...											
Z-750 und Z-1000 motor flange on request												

Material: GGG-50, corrosion-resistant, all screws galvanized nut DIN 934 and spring washers DIN 128. Delivery incl. screws.

1) incl. spring washers

2) incl. nuts and spring washers

3) Threaded bolt 8.8 with nuts and spring washers

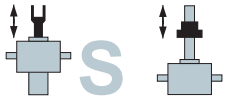

# Three-phase AC motors

## Overview | 0,09 kW - 75 kW

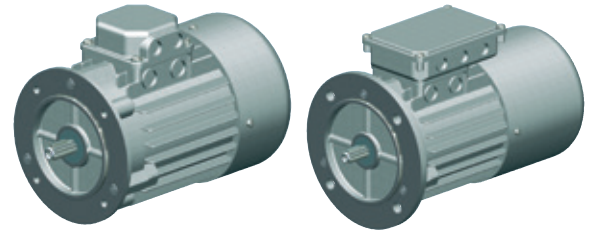

### Technical data

Standard three-phase motors (asynchronous)  
 No-load speed ~1500 rpm (other speeds on request)  
 230/400 V Δ 50 Hz, S1 or S3-75%, ISO F  
 Three-phase AC motors: IP 55  
 Three-phase AC motors with brakes: IP 54

#### Voltage ranges:

220 - 240 V Δ 50 Hz      380 - 415 V VY 50 Hz  
 380 - 415 V Δ 50 Hz      660 - 690 V VY 50 Hz

Size	Power P	Rated speed	Rated torque	Rated current at 400 V	for direct-on-line starting		Breakdown torque to rated torque	Moment of inertia J	Efficiency (at 100% load)	Power factor (at 100% load)	Weight without brake	Weight with brake
IEC	kW	rpm	Nm	A	Starting current to rated current I <sub>s</sub> /I <sub>N</sub>	Starting torque to rated torque M <sub>s</sub> /M <sub>N</sub>	M <sub>k</sub> /M <sub>N</sub>	approx. kgm <sup>2</sup>	η %	cos	approx. kg	approx. kg
56	0,09	1300	0,66	0,35	2,5	1,8	2	0,0002	50	0,76	2,7	4
63	0,18	1330	1,3	0,65	2,3	1,9	1,9	0,0003	58	0,7	4,1	6
63	0,25*	1340	1,81	0,94	2,2	1,7	2,5	0,0004	60	0,76	4,2	6,5
71	0,37	1360	2,6	1,2	2,8	2	2	0,0008	63	0,7	6	8
71	0,75*	1370	5,33	2,1	2,9	2,1	2,4	0,0012	69	0,78	8,3	10,3
80	0,75	1410	5,1	2	4,5	2,2	2,8	0,0020	70	0,7	9,3	13
80	1,5*	1390	10,4	3,4	4,1	3,2	3,2	0,0026	72	0,7	11,5	15,2
90L	1,5	1410	10,3	3,7	4,9	3	3	0,0032	79	0,74	14,4	18
90L	2,2*	1400	15,2	5,2	4,5	2,7	2,7	0,0039	78	0,81	17,5	21,1
100L	2,2	1420	14,8	5,3	4	2,3	2,7	0,0046	83	0,74	19,2	25,5
100L	3	1410	20,3	6,7	3,9	2,3	2,5	0,0056	82	0,79	22,4	28
100L	4*	1420	27	8,9	4	2,2	2,2	0,0065	81	0,82	26,3	31,9
112M	4	1440	27	9,4	3,3	2,5	2,9	0,0133	83	0,75	30,4	38
112M	5,5*	1440	36,4	11,7	3,9	2,1	2,3	0,0139	84	0,83	33	40,6
132S	5,5	1440	36	12	5,8	3	3	0,024	83	0,8	41,9	56
132M	7,5	1440	50	15,4	6,8	3,1	3,1	0,0293	86	0,82	51	66
132M	11*	1445	73,1	24,5	8,2	3,5	3,5	0,0458	83	0,8	74	89
» 160M	11	1460	72,1	20,7	7,6	2,1	2,4	0,0832	89,1	0,86	101	111
» 160L	15	1460	96,2	29,2	7,1	2,4	2,6	0,1506	89,4	0,83	110	120
» 180M	18,5	1465	119	34,3	7,1	2,3	2,6	0,1773	90,4	0,86	135	150
» 180L	22	1475	142	41,1	6,9	2,4	2,6	0,2936	90,9	0,85	145	160
» 200L	30	1475	190	54	6,6	2,1	2,3	0,6345	92,1	0,87	230	253
» 225S	37	1470	238	64,7	7	2,3	2,5	0,3251	92,8	0,89	338	361
» 225M	45	1470	286	77,9	7,4	2,3	2,4	0,7866	92,6	0,9	358	381
» 250M	55	1465	359	94	7,5	2,6	2,6	0,9483	93,4	0,9	482	517
» 250ML	75	1480	484	134	6,3	1,2	2,2	0,9988	94	0,8	535	570

Size 63 to 132 available on short lead times  
 \*Power is higher than the IEC-Norm (progressive)  
 » Size 160 to 355 available on request

### CAUTION

**Overdimensioning** the motor power risks overstressing other components. The effects must be considered not only under load but also for the no-load case.

We supply **motor brakes** as standard for a connection voltage of 230V AC, operating voltage 205 V DC, with bridge rectifiers.

### Ordering example:

**90-P4-1,5-B5-B-2W**

