

SERIES A1100



- ✓ Absolute / relative positioning commands
- ✓ Limited jerk motion commands
- ✓ Time Curves
- ✓ PLC or Stand-Alone Solutions
- ✓ Digital IO's
- ✓ Supports Plug and Play
- ✓ CE / UL / CSA

System Integration

Series A1100 Servo Drives have analog inputs and digital inputs and outputs, serial interfaces, and Bus connections. The user is therefore not dependent on the selection of the higher level controller.

Additionally, the drives can be equipped with optional peripherals, such as reference and end stop switches.

With flexibility and a compact form factor, LinMot Series A1100 Servo Drives provide a complete solution for a flexible drive concept in single and multiple axes applications, with linear motors.

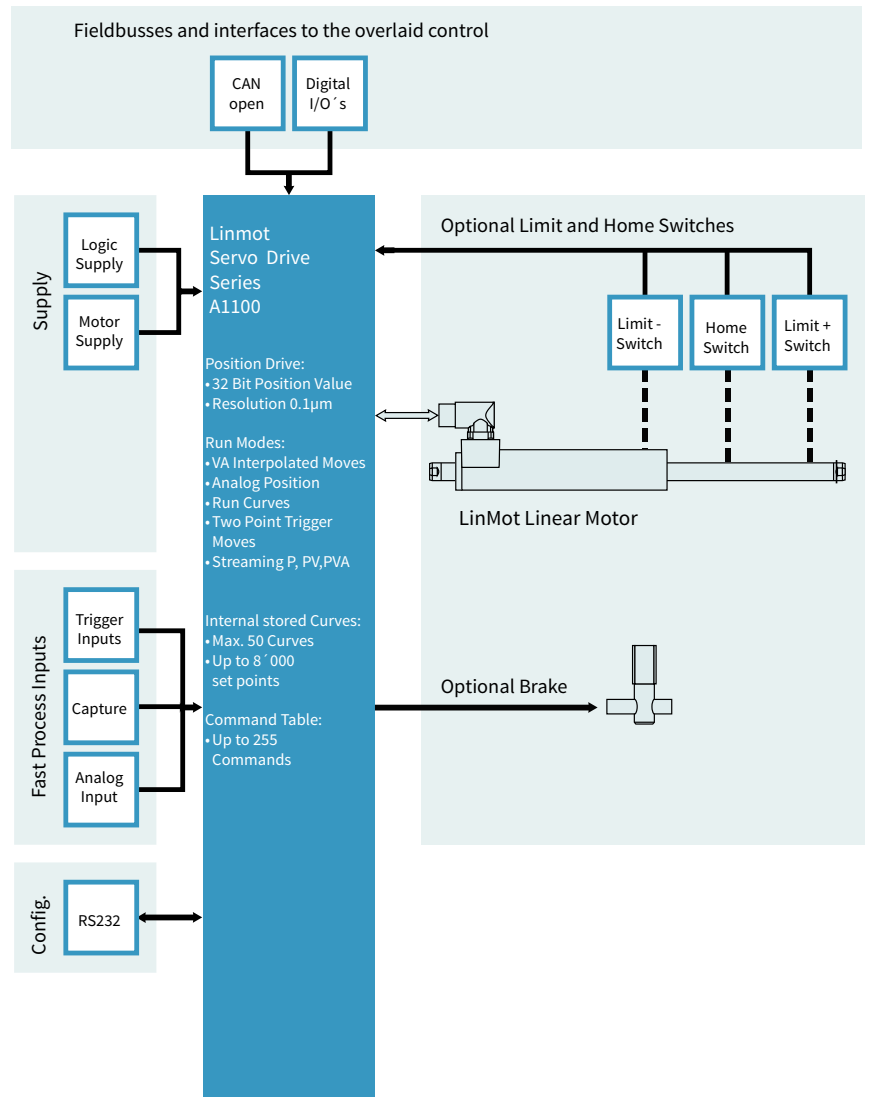

POSITION STREAMING

With a cyclical target value, or “position streaming,” the overarching NC or CNC drive communicates with the Servo Drive through CANopen.

The position and velocity calculated in the overarching drive is transmitted to the Servo Drive cyclically. The P, PV, or PVA mode is available for this transmission.

MOTOR INTERFACES

A1100 Servo Drives provide all necessary interfaces to operate linear motors with optional external peripherals, such as end position and reference switches.

CONFIGURATION

Parameterization and configuration of the Servo Drive is done via RS232.

LinMot Talk user-friendly PC software is available for configuration. In addition to online documentation, LinMot Talk provides extensive debugging tools, such as an oscilloscope and an error inspector, for simple and rapid start-up of the axes.

INTERPOLATED MOVES

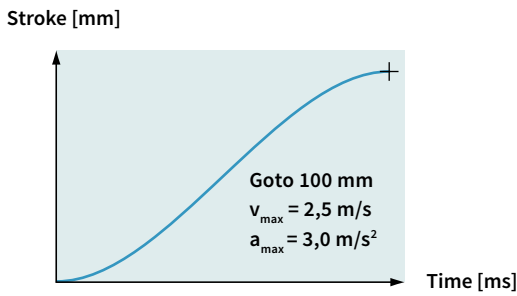

For direct position targets, using absolute or relative positioning, the desired position is reached using acceleration and velocity-limited motion profiles or jerk optimized profiles (jerk limited and Bestehorn). Positioning commands can be invoked via the serial interface, CAN-open or a trigger input.

Stroke range:	±100 m
Position Resolution:	0.1 µm (32Bit)
Velocity Resolution:	1.0 µm/s (32Bit)
Acceleration Resol.:	10.0 µm/s ² (32Bit)

TIME CURVES

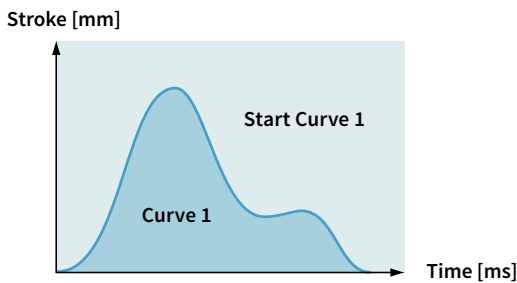

Up to 50 different time curves can be stored in Series A1100 drives, with up to 8,000 individual set points. The motor can thus travel along time curves of any complexity, such as those generated by CAD programs and stored in the drive (Excel CSV format). The time curves can be invoked via the serial interface, fieldbuses or the trigger input.

Stroke range:	±100m
Position Resolution:	0.1 µm (32Bit)
Motion profiles:	Max. 50 Time Curves
Curve points:	Max. 8'000 points

PROFILED MOVES

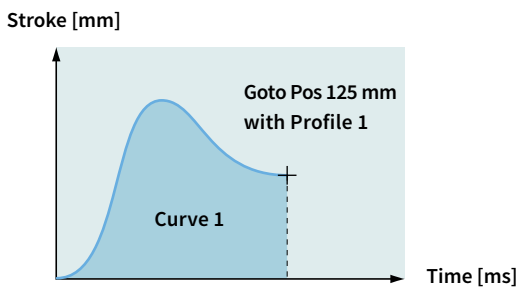

For travel to an absolute position, or shifting by a relative position, any desired motion rules can be stored besides the VA interpolator. They are stored in the drive as motion profiles (Excel CSV format). The positions can be approached, for example, with a sinusoidal motion to optimize power loss, or special reverse optimized motion profiles.

Stroke range:	±100m
Position Resolution:	0.1 µm (32Bit)
Motion profiles:	Max. 50 Time Curves
Curve points:	Max. 8'000 points

SETPOINT STREAMING

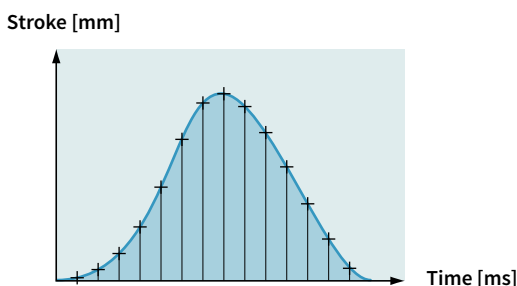

Overlaid NC drives with fieldbus or Ethernet interfaces communicate with the servo drives via "Position Streaming". The position and velocity calculated in the overlaid control is transmitted to the Servo Drive cyclically. The P, PV, or PVA mode is available for this transmission.

Position Resolution:	32 Bit
Velocity Resolution:	32 Bit
Interpolator:	4 kHz
Cycle times:	0.5 - 5 ms

COMMAND TABLE

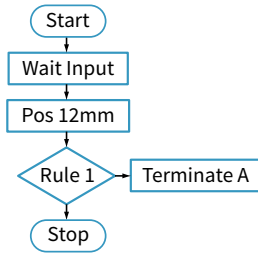

Entire motion sequences with up to 255 individual motion commands can be stored in the Command Table. This is primarily advantageous if complete motion sequences need to be executed very quickly, without dead time from the overlaid PLC. In the Command Table, the programmer has access to all motion commands, internal parameters, and digital inputs and outputs.

Commands: max. 255
Cycle time: 250 µsec

ANALOG POSITION

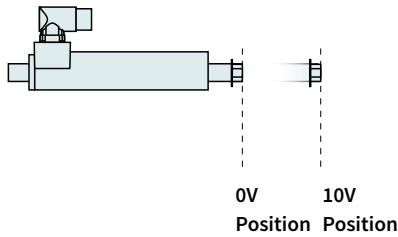

For an analog position target, the linear motor travels to a position proportional to the input voltage. The position is either scanned continuously, or only after a rising edge of the trigger signal. In order to prevent uncontrolled jumps in position, the motor travels to the positions with a programmable maximum acceleration and velocity (VA interpolator).

Inputs: Analog Input X44
Voltage range: 0-10VDC
Resolution: 10 Bit
Scanning rate: 250 µsec

CANopen *Point to Point*

A1100-GP

- » Absolute & Relative Positioning
- » Time based motion profiles
- » Internally stored Motion Sequences
- » Position Streaming
- » Analog Position Target
- » Customer-Specific Functions

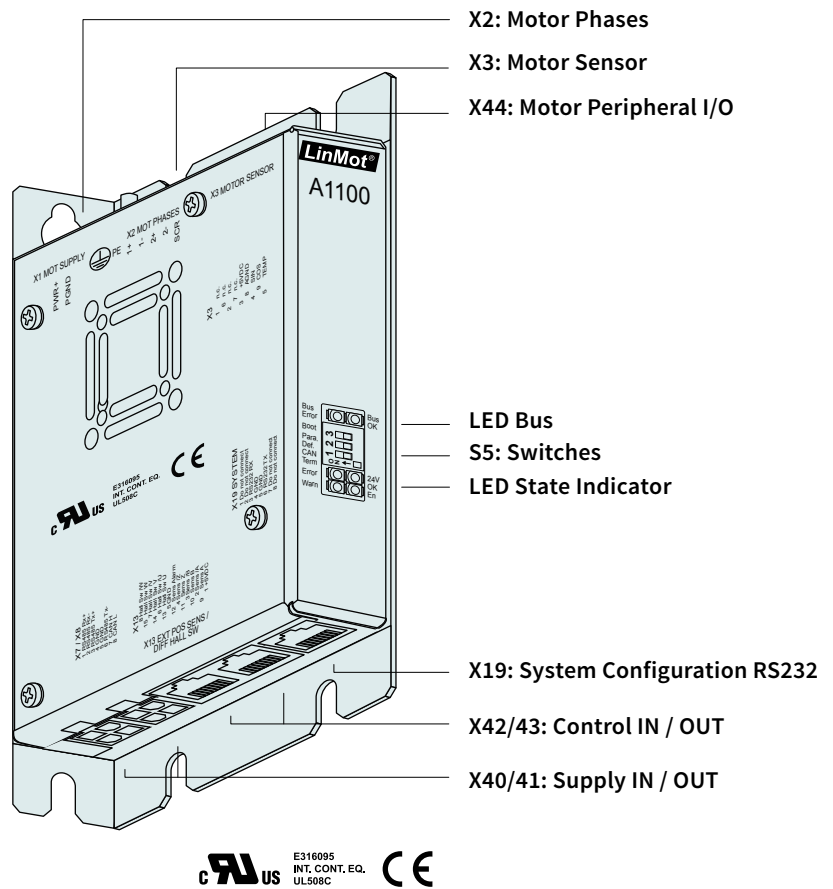

11

CANOPEN

The LinMot A1100-GP drives support the CiA DS301 communications protocol. The following resources are available:
4 T_PDO, 4 R_PDO, 1 T_SDO, 1 R_SDO

The following protocols are also supported by the drives:

- » NMT Error Control (Nodeguarding Protocol or HeartBeat Protocol)
- » PDO (Transmission type 1 to 254)
- » SDO Upload and Download
- » NMT (Start, Stop, Enter PreOp, Reset Node, Reset Communication, Boot-Up Message)

REPLACING PNEUMATICS

Due to their simple controls via digital inputs and outputs, A1100 drives make excellent substitutes for pneumatic cylinders.

Using digital inputs or CAN bus, the linear motor can move to programmable positions. As soon as the linear motor has reached the set position, the In-Position output is actuated.

The linear motor can thus be controlled like a programmable pneumatic cylinder with end position switches.

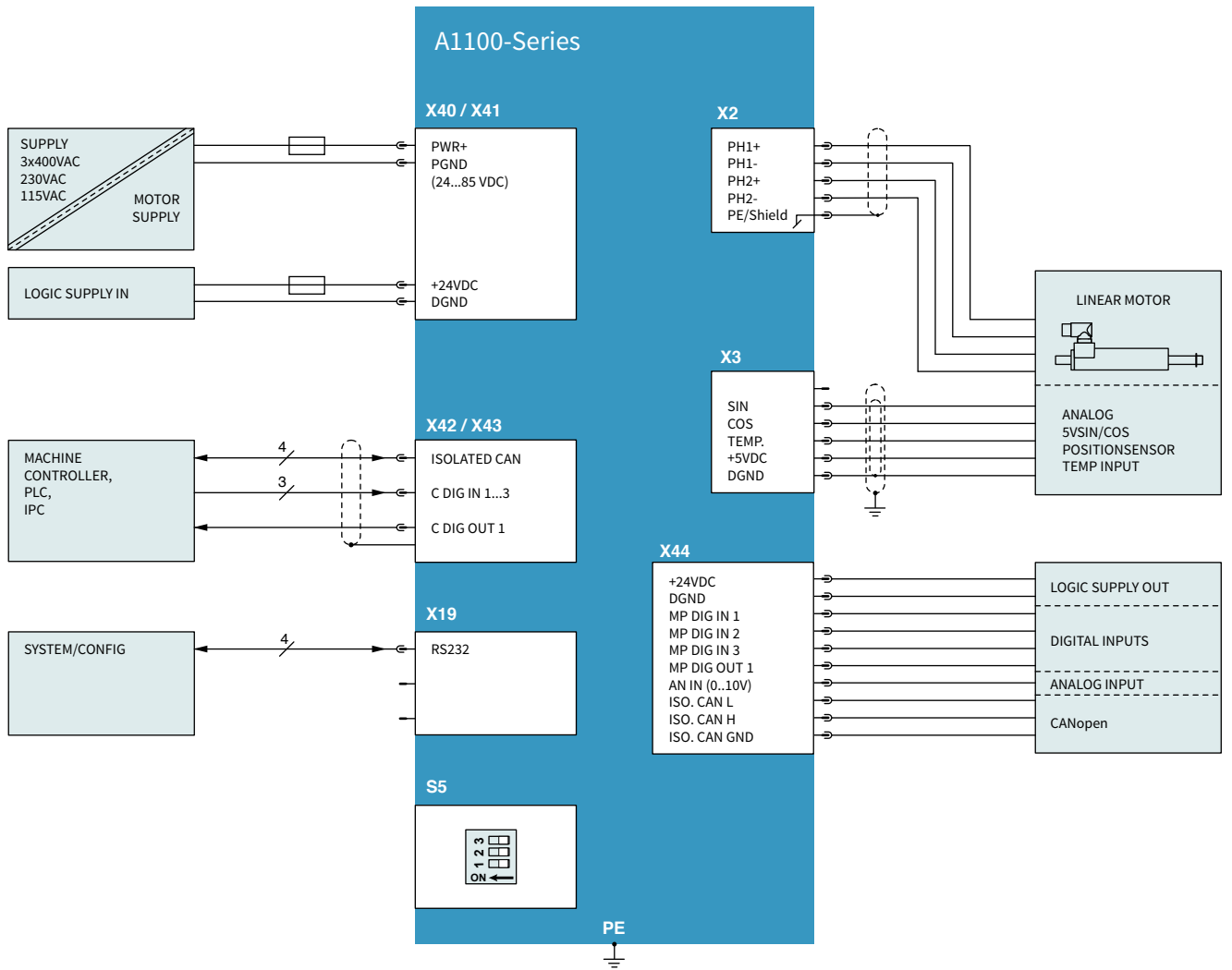

X2 MOTOR PHASES

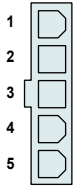

Nr	Designation	LinMot Linear Motor	Color
1	PH1+ /U	Motor Phase 1+	red
2	PH1- /V	Motor Phase 1-	pink
3	PH2+ /W	Motor Phase 2+	blue
4	PH2- /X	Motor Phase 2-	grey
5	SCRN	Shield	

Molex
Mini-Fit Jr.™
Molex Art. Nr.:
50-36-1747

- » Use 60/75°C copper conductors only
- » Cable length <30m
- » 13A max. current per circuit when header is mated to a receptacle loaded with a 45750 Mini-Fit® Plus HCS Crimp Terminal crimped to a 16 AWG wire

X3 MOTOR SENSOR

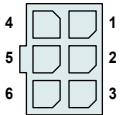

Nr	LinMot Motor
1	DGND
2	Temp
3	Sensor Sine
4	+5VDC
5	(Do not connect)
6	Sensor Cosine

Molex
Mini-Fit 3.0™
Molex Art. Nr.:
43045-0600

- » Use +5V (X3.4) and DGND (X3.1) only for motor internal hall sensor supply (max. 100 mA)
- » Cable length < 30m
- » Caution: Do NOT connect DGND (X3.1) to ground or earth!

MOTOR LINEAR MOTOR WIRING WITH LINMOT MOTOR CABLE (K-, KS- AND KR-TYPES)

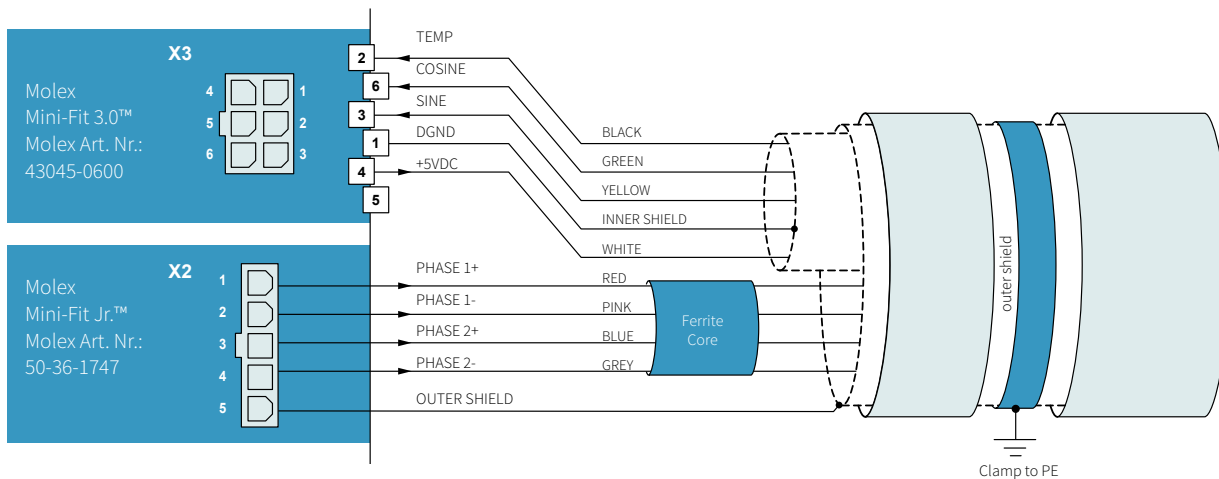

- » For the connection between the linear motor and servo drive, only the specially shielded LinMot cables of type K, KS or KR should be used.
- » The length of the cable can be up to 30 m between the linear motor and the servo drive.
- » Motor cables fabricated by the customer are to be tested with a test voltage of 1500VDC.
- » An improperly fabricated motor cable can damage both the linear motor and the servo drive.
- » The minimum bend radius is to be observed for stationary cables as well as for moving motor cables
- » The motor cable must not be plugged in or unplugged while voltage is still applied.
- » The outer shield of the motor cable has to be clamped to PE as close as possible to the drive.
- » A ferrite core (5mm, 1440hm @ 100MHz, e.g. Würth Elektronik, Art.Nr.: 7427114) has to be mounted around the motor phases as close to the drive as possible.



X40 / X41 SUPPLY IN / OUT

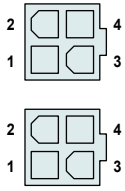

Molex
Mini-Fit Jr.™

Molex Art. Nr.:
50-36-2306

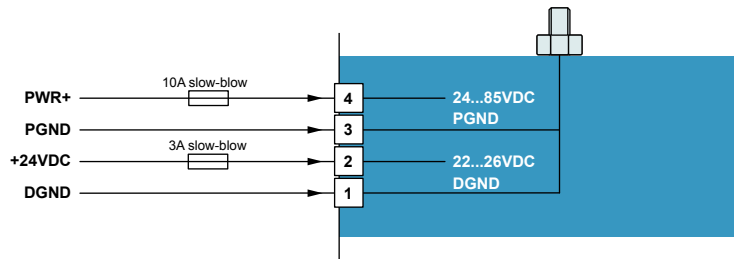

- » Motor Supply: 72VDC nominal, 24...85VDC
- » Absolute max. Rating: 72VDC +20%
- » External Fuse: Motor Supply = 10AT (10A slow blow) / min. 100VDC
Logic Supply = 3AT (3A slow blow) / min. 100VDC
- » If motor supply voltage exceeds 90VDC, the drive will go into error state
- » Use 60/75°C copper conductors only
- » 13A max. current per circuit when header is mated to a receptacle loaded with a 45750 Mini-Fit® Plus HCS Crimp Terminal crimped to a 16 AWG wire

X42 / X43 CONTROL IN / OUT

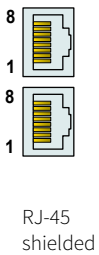

RJ-45
shielded

Nr		
1	C Dig IN 1	Input high voltage: Vin > 16VDC, Input low voltage: Vin < 8VDC
2	C Dig IN 2	Input high voltage: Vin > 16VDC, Input low voltage: Vin < 8VDC
3	C Dig IN 3	Input high voltage: Vin > 16VDC, Input low voltage: Vin < 8VDC
4	CAN GND	
5	CAN GND	
6	C Dig OUT 1	Open Collector Output, 100k Pull-Up to +24VDC
7	Isolated CAN H	
8	Isolated CAN L	
Case	Shield	

- » Use twisted pair (1-2, 3-6, 4-5, 7-8) cable for wiring
- » X42 is internally connected to X43 (1:1 connection)
- » Cable length < 30m.
- » Galvanically isolated CAN transceiver meets the specifications of the ISO11898-2 standard
- » Note: A termination resistor of 120 Ohm can be connected drive internally with the switch S5.1.

X44 MOTOR PERIPHERAL I/O

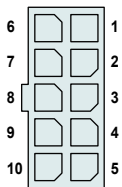

Molex
Mini-Fit 3.0™

Molex Art. Nr.:
43045-1000

Nr		
1	DGND	
2	MP Dig IN 1	Input high voltage: Vin > 16VDC, Input low voltage: Vin < 8VDC
3	MP Dig IN 2	Input high voltage: Vin > 16VDC, Input low voltage: Vin < 8VDC
4	CANGND	Use a separate shielded twisted pair cable for the CAN connection
5	Isolated CAN H	Use a separate shielded twisted pair cable for the CAN connection
6	+24VDC OUT	Max. Current: 2.5A
7	MP Dig OUT 1	Open Collector Output, No Pull-Up, Max. Current: 1.4A
8	MP Dig IN 3	Input high voltage: Vin > 16VDC, Input low voltage: Vin < 8VDC
9	AN IN (0...10V)	Analog Input 0V...10V
10	Isolated CAN L	Use a separate shielded twisted pair cable for the CAN connection

- » Galvanically isolated CAN transceiver meets the specifications of the ISO11898-2 standard
- » The CAN bus on X44 is the same one as on X42/43
- » Note: A termination resistor of 120 Ohm can be connected drive internally with the switch S5.1.
- » Use a separate shielded cable with a twisted pair for CAN L and CAN H when connecting the CAN bus to X44. Clamp the shielding of the cable as close as possible to the drive to PE.
- » Cable length < 30m

X19 SYSTEM

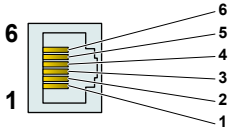

RJ-12 6P6C unshielded

Nr	Description
1	RS232 Tx
2	GND
3	GND
4	RS232 Rx
5	(Do not connect)
6	(Do not connect)

BUS LEDS BUS STATE DISPLAY



BUS State Display	
Green	OK
Red	Error

The use of these LEDs depends on the type of fieldbus which is used. Please see the corresponding manual for further information.

S5



S5.3	Bootstrap (Default = off)
S5.2	Parameter Default (Default = off)
S5.1	CAN Termination (Default = on)

LEDS STATE DISPLAY



State Display	
Green	24V Logic Supply OK
Yellow	Motor Enabled / Error Code Low Nibble
Yellow	Warning / Error Code High Nibble
Red	Error

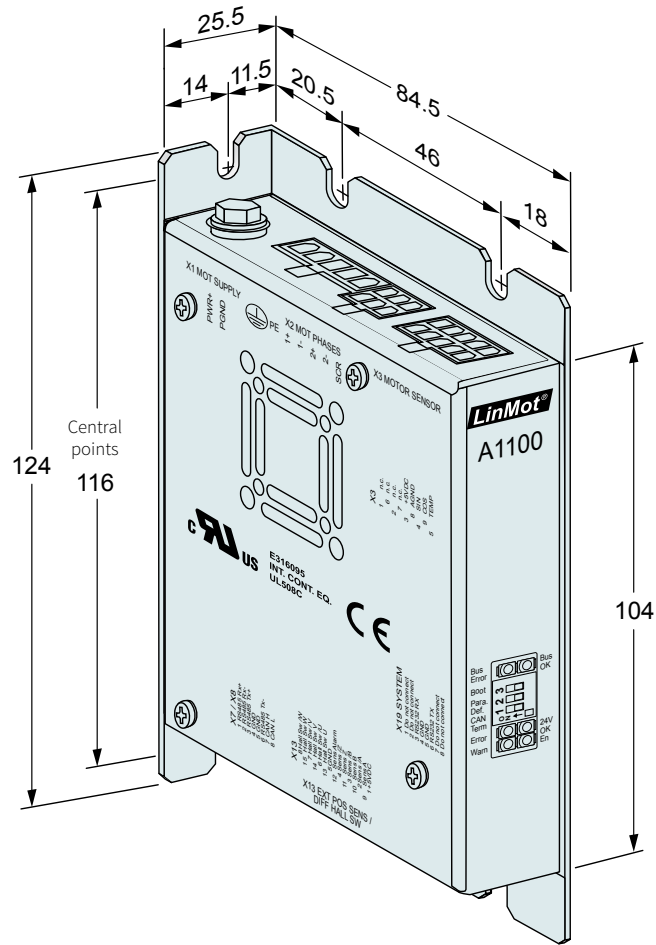

Dimensions in mm
Mounting points for M3 screws

A1100 Single axis drive			
Width	mm (in)	25.5 (1.0)	
Height	mm (in)	124 (4.9)	
Depth	mm (in)	84.5 (3.3)	
Weight	g (lb)	340 (0.75)	
Case	IP	20	
Storage temperature	°C	-25...40	
Transport temperature	°C	-25...70	
Operating temperature	°C	0...40 at rated data (UL) 40...50 with power derating	
Relative humidity	%	95 (non-condensing)	
Pollution	IEC/EN 60664-1	Pollution degree 2	
Max. case temperature	°C	70	
Max. power dissipation	W	30	
Min. distance between drives	mm (in)	20 (0.8)	horizontal
		50 (2)	vertical

Servo Drive		
Item	Description	Part Number
A1100-GP-LC-0S-000	Mini CANopen Drive (72V/8A)	0150-2499

Accessories		
Item	Description	Part Number
DC01-X44-4m	Cable IO 's for A1100/X44, 4 m flying leads	0150-3553
DC01-X40-4m	Cable Supply A1100/X40, 4 m flying leads	0150-3545
DC01-X40/41-0.15 m	Cable IO for A1100/X40-X41, 0.15 m daisy chain	0150-3552