

1. Installation and Disassembly as well as Arrangement of Universal Drive Lines	
1.1 Installation principles	Page 164
1.2 Disassembly	Page 165
1.3 Assembly	Page 165
1.4 Arrangement configurations	Page 166
2. Motion Relationship and Torque	
2.1 Rotation angle of a single joint	Page 167
2.2 Motion and torque characteristics of a single joint	Page 167
2.3 Motion and torque characteristics of a universal joint	Page 168
3. Fluctuation Rate	
3.1 Single joint	Page 169
3.2 Universal joint (2 joints connected in series)	Page 169
3.3 Universal joint with more than two joints	Page 169
4. Offset Angle	
Examples	Page 170
5. Additional Moments on the Universal Joint; Bearing loads on the input and output shaft	
5.1 With Z-arrangement	Page 171
5.2 With W-arrangement	Page 171
5.3 Caused by axial displacement forces	Page 171
6. Fundamental Data for Sizing of Universal Joint	
6.1 Torque	Page 172
6.2 Shock loads	Page 172
6.3 Life expectancy calculation	Page 172
6.4 Life expectancy diagram	Page 173
6.5 Life expectancy diagram, needle bearing	Page 174
6.6 Life expectancy diagram, roller bearing	Page 175
6.7 Speed (rpm) and deflection angle	Page 176
6.8 Critical speeds	Page 176
6.9 Larger tube diameters	Page 177
6.10 Tubing diagram	Page 177
7. Application Principles for Double Joints for Steering Axles	
7.1 Kinematic conditions	Page 178
7.2 Center offset value X and maximum slide movement	Page 179
7.3 Sizing of Double Joints	Page 179
7.4 Loads on the shaft bearing	Page 179
7.5 Torque capacity of double joints as a function of deflection angle	Page 180
8. Hints for application of universal joints	
Needle bearing equipped precision cardan shafts, ball and socket cardan shafts, pin and block cardan shafts	Page 181
9. Transport and Storage – Installation hints	
9.1 Transport and Storage	Page 182
9.2 Installation	Page 182
10. Safety instructions and Maintenance	
10.1 Safety instructions	Page 183
10.2 General maintenance information	Page 183
10.3 Lubrication guidelines	Page 184
10.3.1 Lubricants	Page 184
10.3.2 Maintenance-free Cardan Shafts	Page 184
10.4 Technical information	Page 184
10.5 Control information	Page 184

1. Installation and arrangement of universal drivelines

1.1 Basic installation rules

When a single universal-, cross- or ball joint is rotated uniformly in an angled position, a non-uniform motion occurs at the output side. (See motion characteristics and torques under 2).

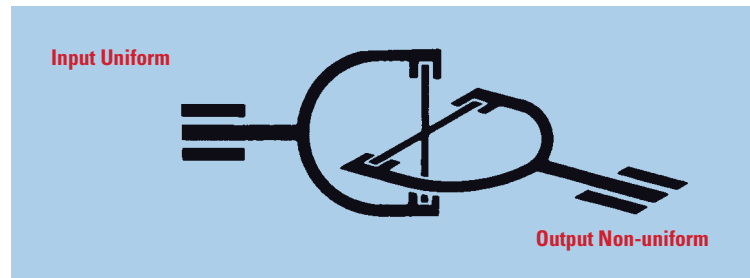

This fluctuation is eliminated when two single joints are connected, forming a driveline. To obtain complete synchronous motion, the following conditions must be met:

- a) Equal deflection angles at both joints ($\beta_1 = \beta_2$)
- b) The two inner forks must be on one plane.
- c) In- and output shaft must also lie on one plane.

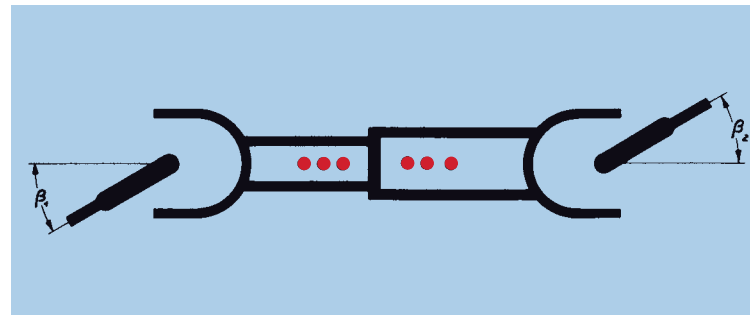

Exception:

If a driveline is angled three-dimensionally, in- and output shafts are not located in one plane. To obtain a uniform output motion, it is necessary in this case to offset the inner forks relative to each other so that they end up in the same plane of deflection created by their joints. Also, the three-dimensional deflection angles must be equal. (Our Engineering Department will gladly assist you in determining the correct angular offset).

Note:

Incorrectly assembled universal joints do not equalize fluctuating output motion. They amplify it. This can lead to early joint bearing and spline failure. Therefore, when assembling the two driveline halves, the marker points on the spline shaft and spline sleeve must face each other.

The cross Journals and the needle bearing cups wear simultaneously. It is therefore necessary to replace both the cross and the needle bearings, if they show signs of wear.

1.2 Disassembly

1. Eliminate the tension between circlips and cups (see picture 1).
2. Remove circlips (with special pliers).
3. Press out one cup at each yoke (see picture 2).
4. Grip cups extending out of the yokes and pull them out (see picture 3). Use aluminium or plastic hammer.
5. Press out and pull off the opposite cup.
6. Remove cross (see picture 4).

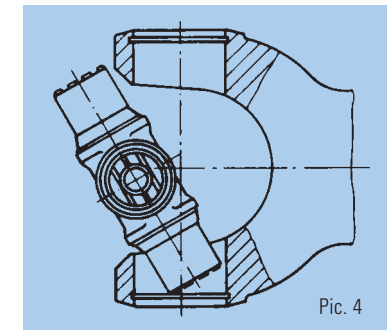
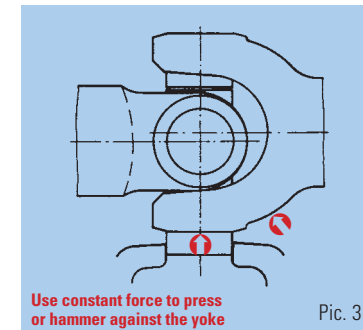
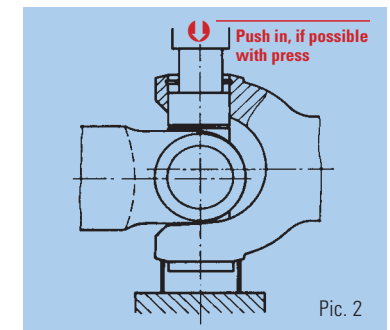
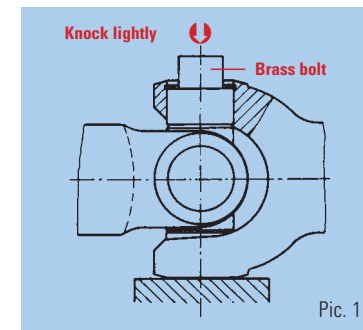

1.3 Assembly.

1. Insert the cross (see picture 4).
2. Press in the bearing cup on one side and secure it with a circlip (see picture 5).
3. Press in and secure the opposite cup (see picture 6).
4. Insert the cross in the second yoke. Then press in the bearing cup and secure it.
5. Tensions in the universal joint can be eliminated by lightly tapping against the yokes with a hammer. The joint will then move more freely.

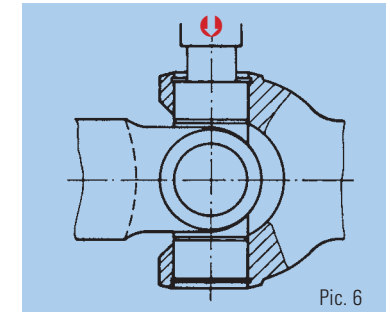
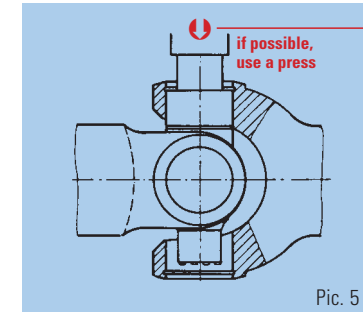

Instructions for Exchanging the Cross Assemblies in Double Joints for Steering Axles:

The bearing cups of the centre piece are fitted with a detaching thread. These cups can therefore be removed with a puller after removing the screw plugs. All other steps for assembling and disassembling are the same as described above.

Attention:

Before pressing in the bearing cups, make sure that all needles are in contact with the inside diameter of the cup. After replacing any worn parts, high-speed shafts must be rebalanced in accordance with rating G16 acc. to DIN ISO 21940. If the shaft is only subjected to low speeds, rebalancing is not necessary. The speed limit lies between 500 and 800 rpm depending on size and design of the shaft. If, for any special reason, high-speed shafts cannot be rebalanced, the individual components of the yoke should be carefully marked before disassembling so that they can be realigned exactly afterwards. In this way the unbalance can be limited to a minimum.

1.4 Arrangement configuration

Z-Configuration:

Input and output shaft are parallel to each other on one plane.

Requirement: $\beta_1 = \beta_2$

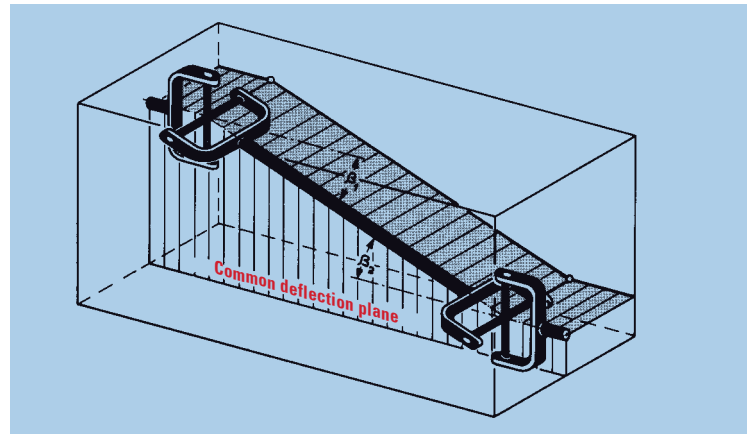

W-Configuration:

Input and output shaft intersect on one plane.

Requirement: $\beta_1 = \beta_2$

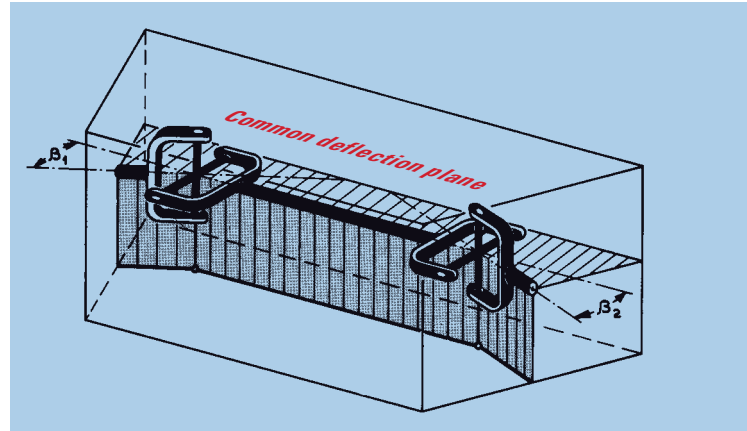

Three-dimensional configuration:

(Combined Z and W configuration)
Input and output shaft cross each other offset in space. No common plane exists. Therefore the inner forks must be offset by the angle γ (See 1.1 „Exception“).

Requirement: $\beta_{R1} = \beta_{R2}$

The resultant three-dimensional deflection angle β_R derived from the vertical and horizontal angular deviation, is calculated as:

$$\beta_R = \arctan \sqrt{\tan^2 \beta_v + \tan^2 \beta_h}$$

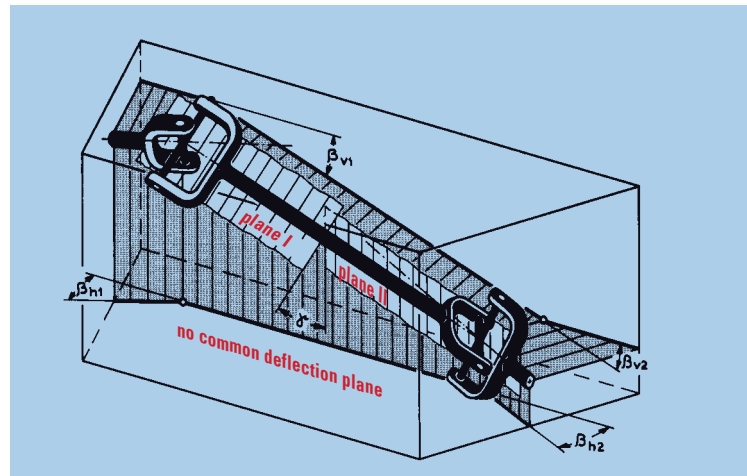

2. Motion relationships and torques

2.1 Rotation angle of a single joint as a function of deflection angle β

φ_1 = Input – rotation angle
 φ_2 = Output – rotation angle

If a single joint is deflected by angle β and rotated in this condition, rotation angle φ_2 of the output shaft differs from rotation angle φ_1 of the input shaft. The relationship between the two rotation angles is as follows:

$$\tan \varphi_2 = \frac{\tan \varphi_1}{\cos \beta}$$

As can be seen from the adjacent diagram, maximum lead occurs at about 45° , maximum lag at about 135° .

Fork position $\varphi_1 = 0^\circ$ is then obtained, when the input fork is located in the deflection plane of the joint.

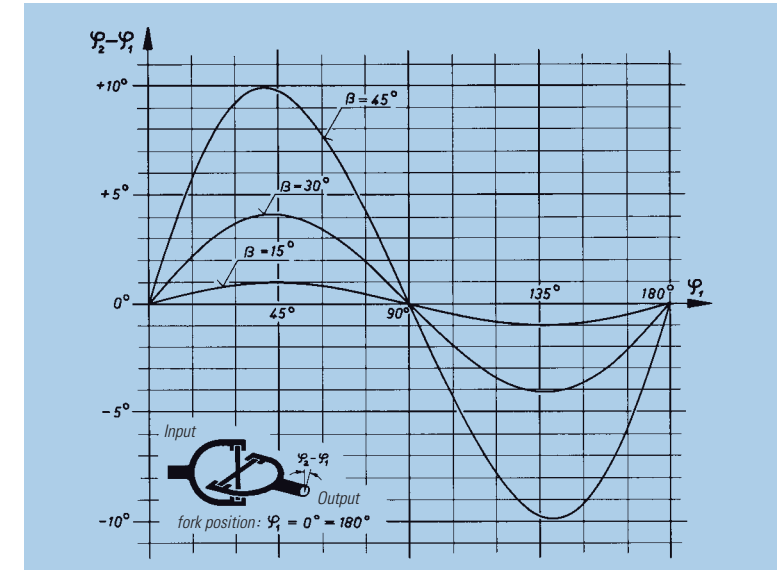

2.2 Motion and torque characteristics of a single joint as a function of deflection angle β

M_{dI} = Input torque
 M_{dII} = Output torque
 ω_I = Input – angular velocity
 ω_{II} = Output – angular velocity

When analyzing the motion and torque characteristics of a singular joint, it is found that with a constant angular velocity- and torque input, a fluctuating motion and torque curve is obtained at the output. The reason for this fluctuation can easily be illustrated by following the torque characteristics at the fork position $\varphi_1 = 0^\circ$ and $\varphi_1 = 90^\circ$ as shown at left. Since the torque can only be transmitted in the spider plane, the spider however, depending on the fork position, is always at a right angle to the input or output axis, output torque fluctuates twice per revolution between $M_{dI} \cdot \cos \beta$ and $M_{dI} / \cos \beta$.

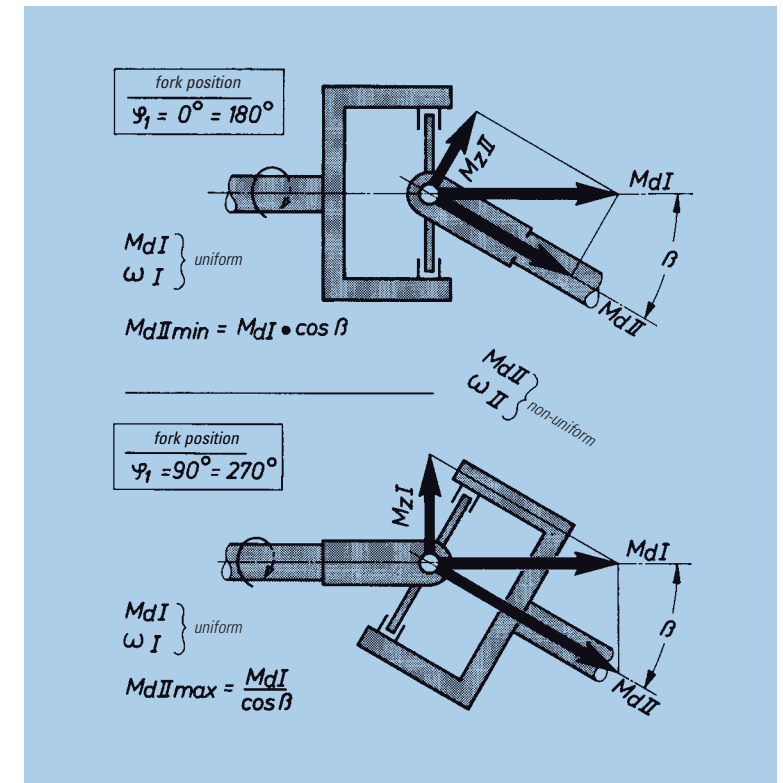

The transmitted power, however, is constant, if you disregard friction losses in the bearings.

Therefore, the following applies:

$$N_I = N_{II} = \text{Constant}$$

$$M_{dl} \cdot \omega_I = M_{dII} \cdot \omega_{II} = \text{Constant}$$

$$\frac{M_{dl}}{M_{dII}} = \frac{\omega_{II}}{\omega_I} = \frac{\cos \beta}{1 - \cos^2 \varphi_1 \cdot \sin^2 \beta}$$

For fork position $\varphi_1 = 0^\circ$ we obtain:

$$\frac{M_{dl}}{M_{dII \min}} = \frac{1}{\cos \beta} = \frac{\omega_{II \max}}{\omega_I}$$

and for fork position $\varphi_1 = 90^\circ$:

$$\frac{M_{dl}}{M_{dII \max}} = \cos \beta = \frac{\omega_{II \min}}{\omega_I}$$

2.3 Motion and torque characteristic of a universal driveline

as a function of deflection angles β_1 and β_2

Section 2.2 illustrates that angular velocity and torque at the output of a single joint follow a sinusoidal pattern with a 180° cycle. Maximum angular velocity $\omega_{II \max}$ coincides with minimum torque $M_{dII \min}$ and vice versa. From this it can be deduced that a uniform output is possible, when a second joint, with a 90° phase shift is connected to

$$\frac{M_{dl}}{M_{dII}} = \frac{\omega_{II}}{\omega_I} = \frac{M_{dII}}{M_{dl}}$$

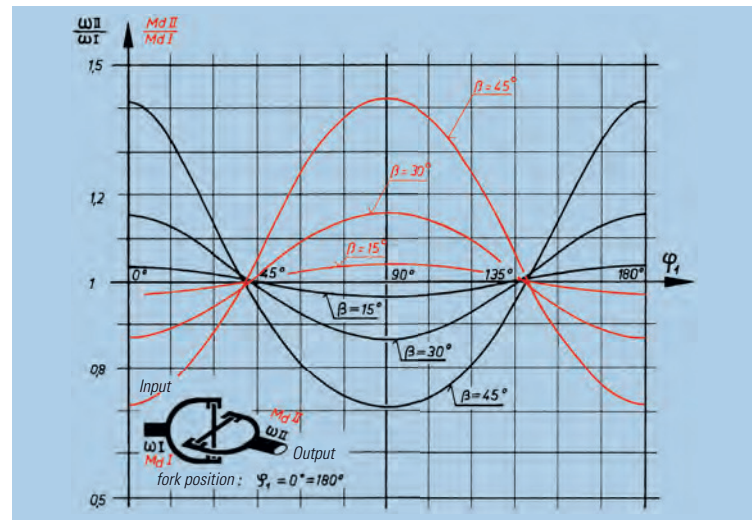

the first joint by means of a shaft. Then, the non-uniform motion of the first joint can be balanced by the non-uniform motion of the second joint. The required 90° phase shift is always met, when the two inner forks happen to be in the deflection plane of their respective joints. Moreover, the two deflection angles β_1 and β_2 of both joints must be the

same. (See also Section 1.1 and 1.4).

With unequal deflection angles, complete compensation is not possible.

For $\beta_2 > \beta_1$ the following applies:

$$\left(\frac{\omega_{II \min}}{\omega_I}\right)_{\max} = \frac{\cos \beta_1}{\cos \beta_2}$$

$$\left(\frac{\omega_{II \min}}{\omega_I}\right)_{\min} = \frac{\cos \beta_2}{\cos \beta_1}$$

$$\left(\frac{M_{dII}}{M_{dl}}\right)_{\max} = \frac{\cos \beta_1}{\cos \beta_2}$$

$$\left(\frac{M_{dII}}{M_{dl}}\right)_{\min} = \frac{\cos \beta_2}{\cos \beta_1}$$

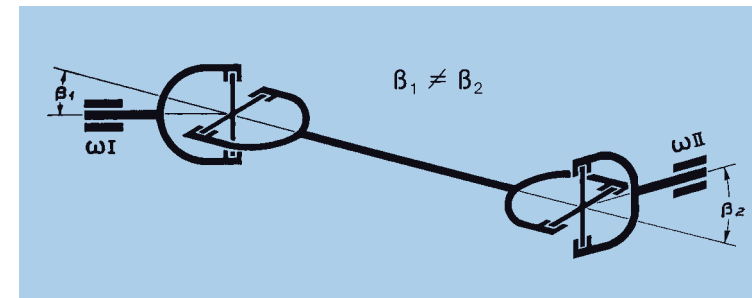

3. Fluctuation rate

3.1 Single joint

As explained under 2.1, on a single joint the output velocity deviates from the input velocity. This means, the speed ratio is not uniform. This non-uniformity (fluctuation) can be calculated as a dimensionless value:

Fluctuation rate

$$U = \frac{\omega_{2 \max} - \omega_{2 \min}}{\omega_1} = \frac{1}{\cos \beta} - \cos \beta$$

3.2 Universal driveline (2 joints connected in series)

If the preconditions listed in Chapter 1 for obtaining a complete motion compensation cannot be met, it must be aimed for that: $U \leq 0,0027$.

3.3 Universal driveline with more than two joints

Design requirements might dictate the use of a universal driveline that employs more than 2 joints. This universal driveline, however, must then incorporate an intermediate bearing.

Here, also, the condition applies:

$$U_{Res} \leq 0,0027$$

Here, U_{Res} expresses the total fluctuation of the driveline.

Observe, when determining U_{Res} :

- Joints with the same fork position get the same sign.
- The fluctuation rate of each joint must be calculated individually U_1, U_2, U_3 .
- The signs must be observed when adding:

$$U_{Res} = \pm U_1 \pm U_2 \pm U_3$$

Since the rate of fluctuation is a function of deflection angle β , a limiting condition can be set in regard to the resulting deflection angle β_{Res}

$$\beta_{Res} = \sqrt{\pm \beta_1^2 \pm \beta_2^2 \pm \beta_3^2} \leq 3^\circ$$

β_{Res} corresponds to the deflection angle of a single joint if it were to replace the entire driveline.

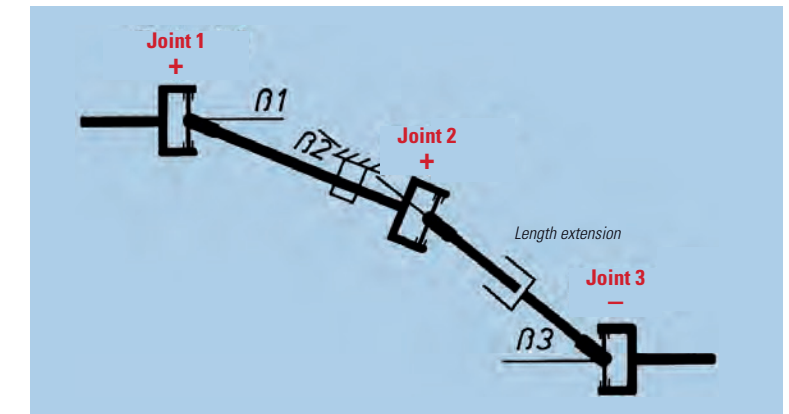

4. Offset angle

On drivelines with three-dimensional deflection angles, input and output shaft are not located in one plane. This results, if no special measures are taken, in a non-uniform output motion. The constantly repeating acceleration and deceleration unleashes inertia forces which can greatly reduce the life of the joints.

However, not only the driveline, the driven equipment also is subjected to these forces and vibration caused by them. To avoid this, the inner forks must be offset relative to each other such that each fork ends up in the plane of deflection of its joint. The angle between both deflection planes is called offset angle γ

and it can be obtained as follows.

Example 1

$$\tan \gamma_1 = \frac{\tan \beta_{h1}}{\tan \beta_{v1}} ; \tan \gamma_2 = \frac{\tan \beta_{h2}}{\tan \beta_{v2}}$$

Offset angle $\gamma = \gamma_1 - \gamma_2$

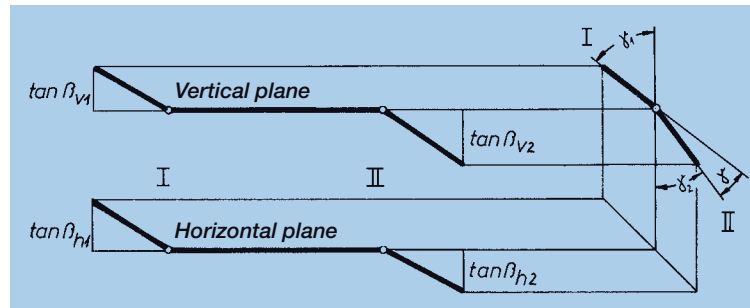

Example 2

$$\tan \gamma_1 = \frac{\tan \beta_{h1}}{\tan \beta_{v1}} ; \tan \gamma_2 = \frac{\tan \beta_{h2}}{\tan \beta_{v2}}$$

Offset angle $\gamma = \gamma_1 + \gamma_2$

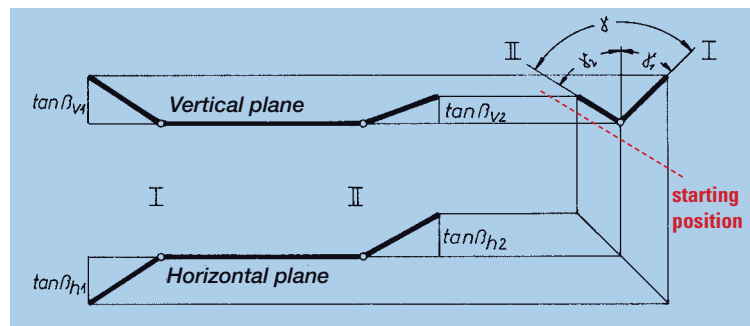

As shown by the graphic illustrations, in both examples two directions of rotation are possible:

Example 1:

- Rotate joint 1 counter clockwise by the offset angle
- Rotate joint 2 clockwise by the offset angle.

The direction for viewing is, in both cases, from joint 1 to joint 2.

Example 2:

- Rotate joint 1 counter clockwise by the offset angle
- Rotate joint 2 clockwise by the offset angle.

The direction for viewing is, in both case, from joint 1 to joint 2.

To determine the turning direction of the offset angle, you always have to take the graphic illustration.

Only in this way is it possible to find the right direction of rotation and to determine whether the offset angle γ_1 and γ_2 have to be summed or have to be subtracted

5. Additional moments on the drive line; Bearing loads on the input and output shaft

In Section 2.2 it was shown that the torque is transmitted only in the spider plane and that depending on the fork position, the spider can be perpendicular either to the input axis or the

output axis. What additional forces and moments this causes on the driveline as well as on the bearings of the input and output shaft, is

explained briefly in the following chapter.

5.1 With Z-Arrangement

The adjacent illustration shows the location and direction of the additional forces and moments on drivelines having a Z-arrangement, in particular for yoke angles $\varphi_1 = 0^\circ$ and $\varphi_1 = 90^\circ$. This shows clearly, that the driveline center part is stressed by the torque which fluctuates between $M_{dl} \cdot \cos \beta$ and $M_{dl} / \cos \beta$ in torsion and by the additional periodically alternating, moment M_{ZII} in bending.

(See also Section 6.8).

Likewise, input and output shaft are stressed by M_{ZI} and M_{ZIII} periodically alternating in bending. The resulting bearing loads A and B vary twice per revolution between 0 and maximum value.

Bearing loads on input and output shaft with Z-arrangement

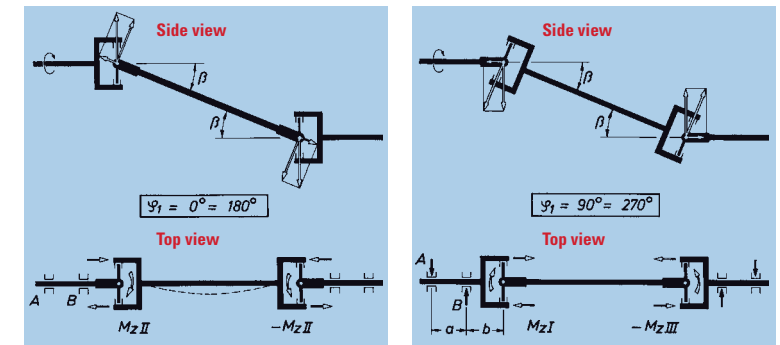

Driveline-center part stressed in bending

$$A = B = 0$$

Driveline-center part stressed in bending

$$A_{\max} = B_{\max} = \frac{M_{dl} \cdot \tan \beta}{a} \quad [N]$$

5.2 With W-Arrangement

According to the adjacent illustration, with the W-arrangement, an additional force, "S" is introduced, caused by the additional moments M_{ZII} acting in the same direction. The maximum force value occurs at fork position $\varphi_1 = 0^\circ$, and it is transmitted to the input and output shaft by the faces of the spider pins.

Bearing loads on input and output shaft with W-arrangement

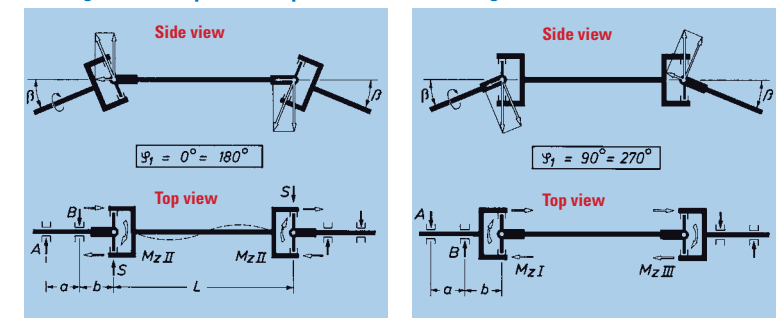

Input and output shaft stressed in bending

$$A = \frac{2 \cdot M_{dl} \cdot \sin \beta \cdot b}{L \cdot a} \quad B = \frac{2 \cdot M_{dl} \cdot \sin \beta \cdot (a+b)}{L \cdot a}$$

Input and output shaft stressed in bending

$$A = B = \frac{M_{dl} \cdot \tan \beta}{a} \quad [N]$$

5.3 Caused by axial displacement forces

If a driveline with an adjustable spline is being changed in length while under torque, in both cases, Z- or W configuration, addition bearing loads are introduced, resulting from the friction caused in the spline. The axial dis-

placement force P_a responsible for these bearing loads is calculated as follows:

$$P_a = 2 \cdot M_{dl} \cdot \mu \left(\frac{1}{d_m} + \frac{\sin \beta}{\ddot{U}} \right) \quad [N]$$

d_m is the spline pitch diameter, \ddot{U} the spline

overlap. Depending on configuration and lubrication, the coefficient of friction for steel on steel must be assumed to range from 0.11 to 0.15. Plastic coated splines have considerably better sliding characteristics. Here, the friction value is approximately 0.08. Rilsan coated splines are available from size 0.109 up.

6. Fundamental data for sizing of universal drivelines

To size universal drivelines properly, various conditions and factors must be considered. In view of the multitude of possible applications, exact, generally valid rules cannot be

provided. The following information is therefore used for the first rough determination of size. In case of doubt, we will gladly compute the required joint sizes for you and, in this

context, we like to refer to the technical questionnaires starting on page 189.

6.1 Torques

The max. permitted torques $M_{d_{max}}$ stated for the individual drive-shaft sizes apply normally only for short-term peak loads.

$M_{d_{nom}}$: Nominal torque for pre-selection on the basis of the operating moment.

$M_{d_{lim}}$: Limit torque that may be transmitted temporarily from the universal-drive-joint at limited frequency without functional damage.

The respective permissible torque has to be calculated individually depending on the remaining operating data, such as shock loads, angle of deflection, rotation, etc. (See item 6.2 and 6.3)

6.2 Shock loads

Depending on the type of power input or installation, a driveline can be subjected to shock loads considerably above the rated torque. To take those into account, shock service factors must be implemented. Following are some shock-service factors for the most common drives

Prime mover	with flexible coupling	without flexible coupling
Turbine or electric motor	1	1 to 1,5
Gasoline engine, 4 and more cylinders	1,25	1,75
Gasoline engine, 1 to 3 cylinders	1,5	2
Diesel engine, 4 and more cylinders	1,5	2
Diesel engine, 1 to 3 cylinders	2	2,5

Of course, not only the drives, but, in many instances, also the driven equipment is responsible for shock loads. Because of the magnitude of different possibilities, general data valid for every use cannot be supplied.

6.3 Life expectancy – calculation

The decisive factor with regard to life expectancy of universal drivelines is usually the joint bearing. Therefore, in order to determine the individually required joint size, the life expectancy diagram shown later on should be used. This diagram allows to:

- determine the theoretical life expectancy of a selected driveline as a function of prevailing operating conditions, or
- to determine the required joint size for a given life expectancy.

In this case, the rated input torque is multiplied by the appropriate service (shock) factor and the M_d such obtained entered in the following diagram. Other factors, such as correction - or deflection angle factor do not have to be considered since they are already incorporated in the diagram.

On machines or vehicles with changing operating conditions, at first, the individual life expectancy values (for each condition) must be determined from the diagram. Then the overall life expectancy L_{hR} can be calculated as follows:

$q_1, q_2 \dots$ = time share in [%]
 $L_{h1}, L_{h2} \dots$ expressed in 10^3 [Hours]

$$L_{hR} = \frac{100000}{\frac{q_1}{L_{h1}} + \frac{q_2}{L_{h2}} + \dots + \frac{q_n}{L_{hn}}} \text{ [Hours]}$$

6.4 Life expectancy-Diagram

In view of the multitude of applications, it is not possible to determine the suitability of a driveline by tests. Therefore, the selection and analysis of the required joint size is done by calculations. These are based on the computation of the dynamic load carrying capacity of full rotation needle - and roller bearings according to ISO recommendation R 281. The life expectancy diagrams shown in the catalogue are based on this recommendation and also on an equation formula especially suited for obtaining nominal life expectancy on universal joints. The thus obtained life expectancy lists the hours of operation that will be reached or exceeded by 90% of a larger number of equivalent universal joint bearings.

There are also methods of obtaining the modified life expectancy. In this case varying survival probabilities, material quality and operating conditions are taken into account. The present technical know how does not allow statements to be made about variations in life expectancy performance resulting from differences in steel quality (grain, hardness, impurities). For this reason, no guidelines have been set in the International Standards.

All pertinent operating conditions, such as operating temperature, lubrication intervals, the type of grease used and its viscosity in operation, must also be considered. Since these factors vary from case to case, it is not possible to determine the modified life

expectancy and accordingly, a life expectancy diagram valid for universal use.

The two following life expectancy diagrams will allow you to roughly determine the nominal life expectancy.

If the deflection angle is smaller than $\beta = 3^\circ$, $\beta = 3$ should be used. Otherwise, the obtained result will be less accurate.

If it is necessary to determine the life expectancy accurately, kindly consult the ELBE Engineering Department.

6.5 Life expectancy diagram, Needle bearing

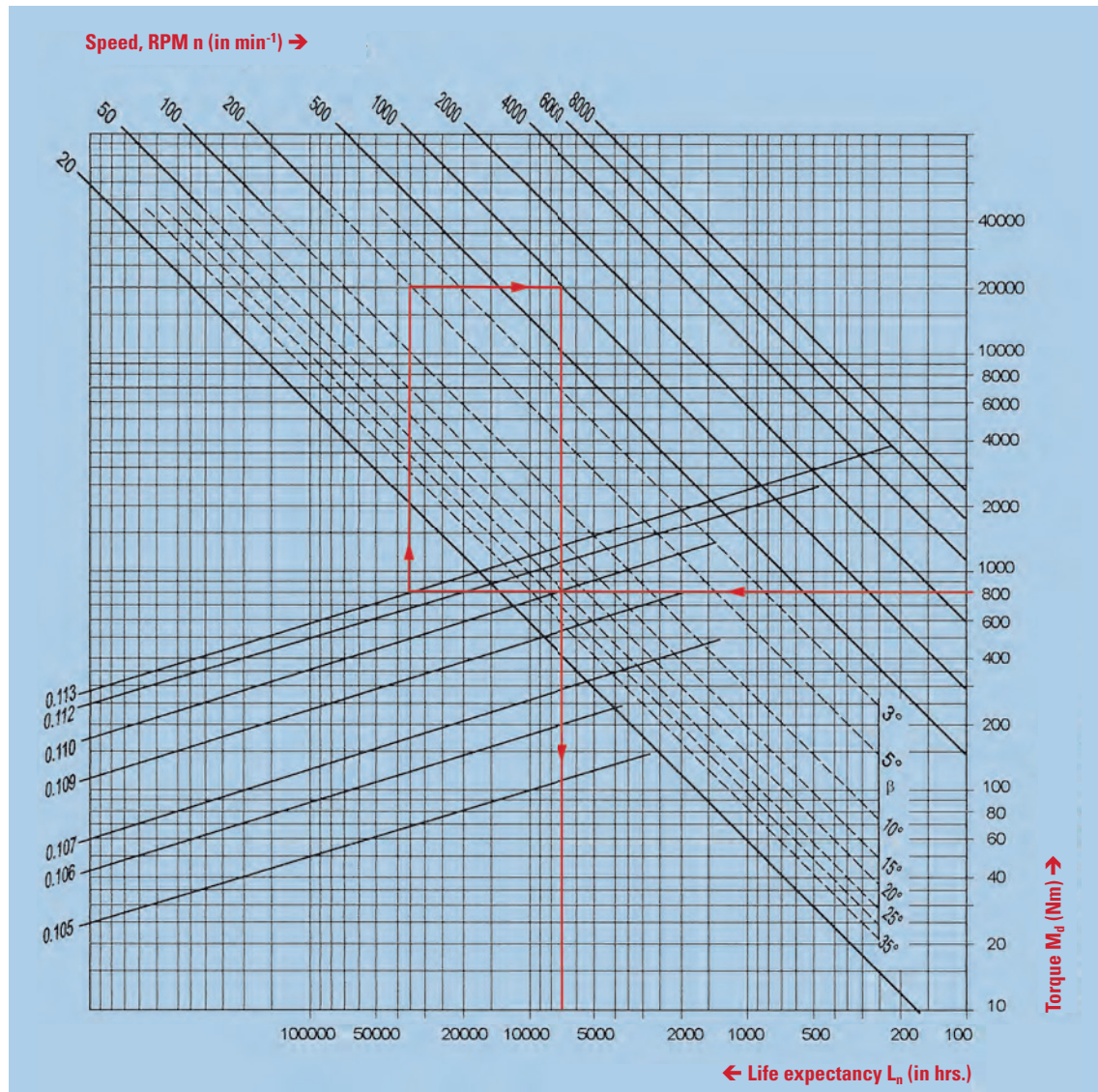

Example

Universal driveline 0.113

Torque	M_d	=	800 Nm	} →
Deflection angle	β	=	5°	
RPM	n	=	1000 min ⁻¹	

Life expectancy = 6900 hrs.

Procedure:

Torque → Joint size → Deflection angle → RPM → Life expectancy

6.6 Life expectancy diagram, Roller bearing

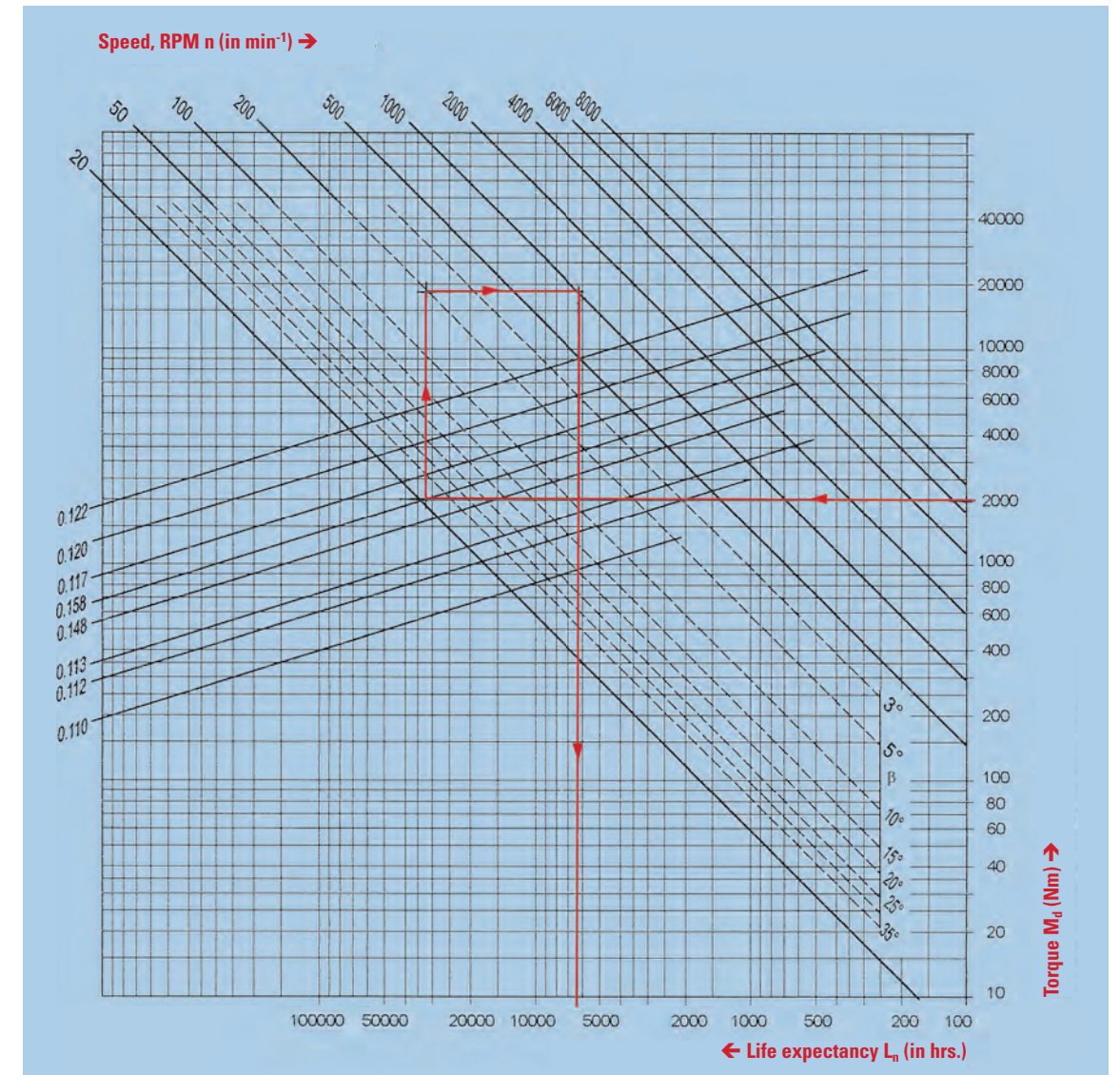

Example

Universal driveline 0.158

Torque	M_d	=	2000 Nm	} →
Deflection angle	β	=	5°	
RPM	n	=	1000 min ⁻¹	

Life expectancy = 7000 hrs.

Procedure:

Torque → Joint size → Deflection angle → RPM → Life expectancy

6.7 RPM and deflection angle

As shown in 2.3 by taking certain precautions, a constant output can be obtained on a universal driveline. The center part, however, still retains a non-uniform motion; it is subjected twice per revolution to an acceleration and deceleration. The resulting acceleration torque caused this way is a function of the mass moment of inertia of the driveline's

center part as well as of rpm and deflection angle. When regarding smoothness of operation and wear, the product of rpm and deflection angle should not be too high. For use in general mechanical engineering, appropriate guide values can be taken from the diagram below, which is designed for universal drivelines having a standard tubing of up

to 1500 mm length. For vehicle drive trains, these guide values must often be exceeded. Here, at most, up to 1.5 times the diagram value can be permitted.

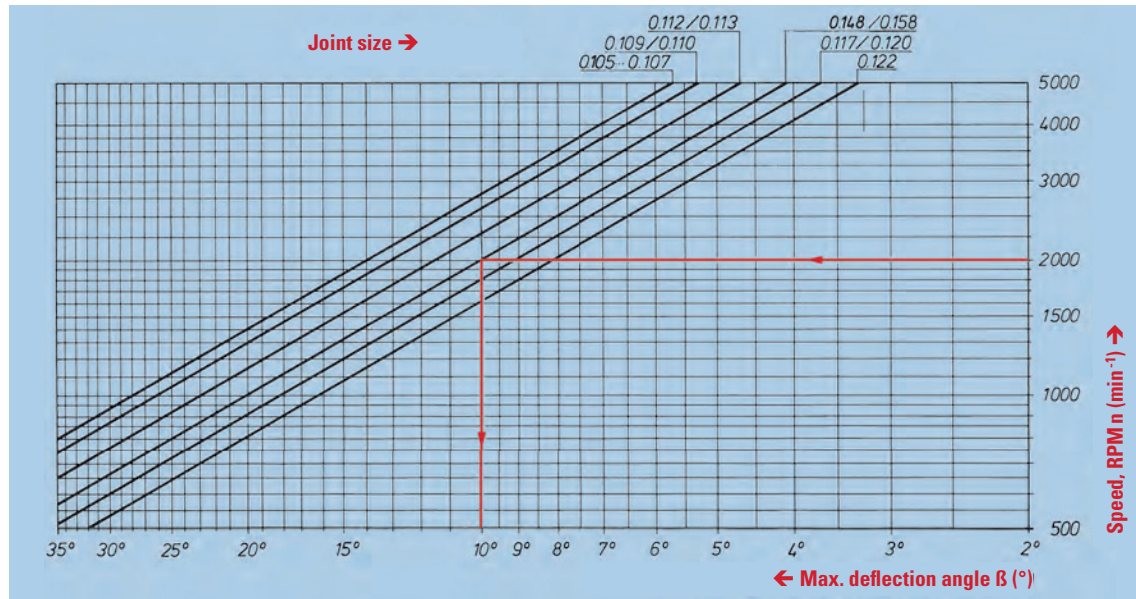

6.8 Critical speeds

As shown in 5.1, the center part of the angled driveline, when transmitting torque, is stressed periodically in bending by additional moment M_{Zil} . This incites the center part to vibrate. If the frequency of this bending vibration approaches the natural frequency of the driveline, maximum stress in all components, buckling of the shaft and development of noise will result.

To avoid this, long and fast running drivelines must be checked for critical bending vibration speeds. The critical, first order bending vibration speed of a driveline employing tubing can be roughly calculated as follows:

$$n_{kr} \approx 1,21 \cdot 10^8 \frac{\sqrt{D^2 + d^2}}{L^2} \text{ [min}^{-1}\text{]}$$

D = Tubing-outside diameter [mm]
d = Tubing-inside diameter [mm]
L = Center part length in [mm]

Drivelines are used in the subcritical zone only. For reasons of safety, it must be ensured that the maximum operating speed is far enough away from its system's resonance (critical) speed. Therefore, the following applies:

$$\text{Max. Operating Speed } n_{max} \approx 0,65 \cdot n_{cr} \text{ [RPM]}$$

6.9 Larger tubing diameters

The critical bending vibration speed of a driveline is, as can be seen from the critical rpm formula, a function of tubing diameters and length of center part. By going to larger tubing diameters, the critical speed of a driveline can be increased. However, the diameter increase must remain within defined limits since a certain relationship between tubing dimensions and joint size must be adhered to.

The dimension sheets of the different driveline models list the possible tubing dimensions for each size. In all the cases where a single driveline is insufficient, multiple arrangements with intermediate bearings must be used.

It must be noted that larger tubing diameters are feasible only above a certain shaft length. The following minimum lengths can be used as an angle line.

Flange diameter [mm]	Up to 65	75 to 100	120 to 180
Min. length S [mm]	650	950	1250

6.10 Tubing diagram

For determining the required tubing diameter when maximum operating speed n_{max} and center part length L are given.

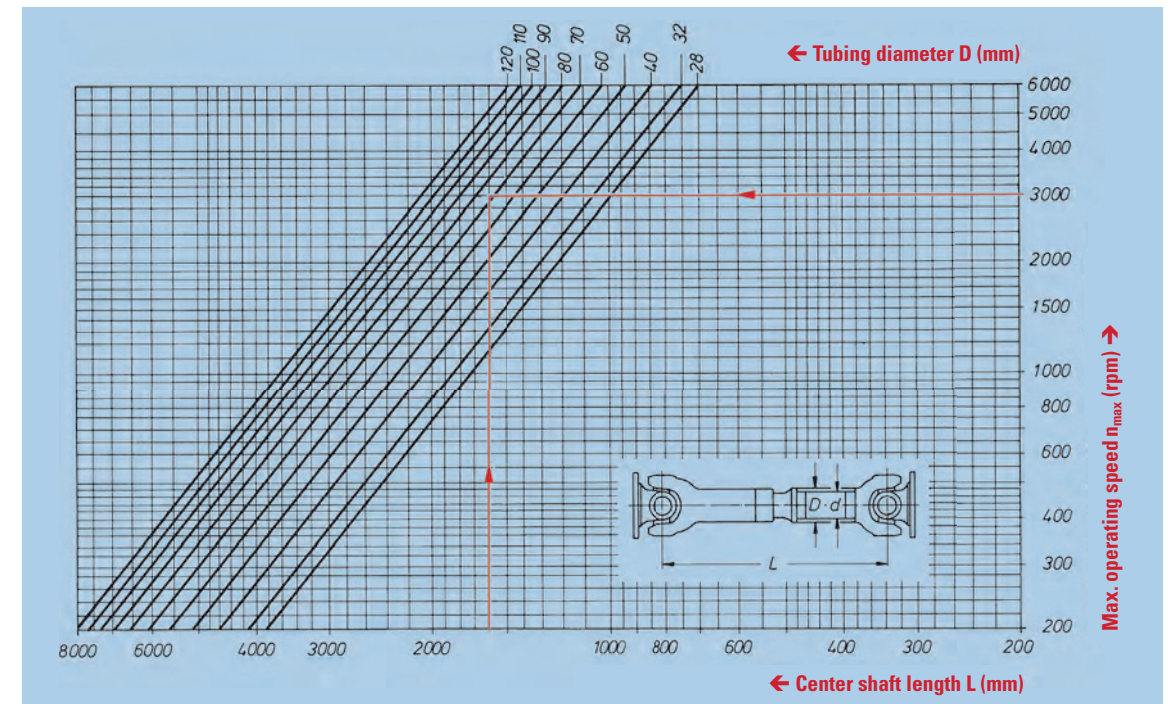

Example:

Center shaft length L = 1600 mm } Obtained: Tubing diameter ≥ 70 mm
Max. operating speed n_{max} = 3000 RPM

7. Application principles for double joint shafts in steering axles

The double joint shafts of series 0.400.5 and 0.500.3 are intended for use in powered steering axles only.

7.1 Kinematic conditions

As shown in the sketch below, when steering is activated, the axle system is rotated around pin center **D**. The double joint deflects at its two joint pivot points **A** and **B**. Since shaft II is fixed axially, shaft I must move in the direction **S**. This causes unequal joint deflection angles β_1 and β_2 , and therefore, also a non-uniform (fluctuating) output motion. The fluctuation can be kept very small provided joint center **C** is offset toward the fixed side by the

compensation value **X**. This way, at a certain deflection angle (= synchronous motion angle β_x) completely uniform motion is obtained, i.e., the two joint deflection angles β_1 and β_2 are equal. $\beta_x = 30^\circ$ bis 35° would be an appropriate synchronous motion angle to select

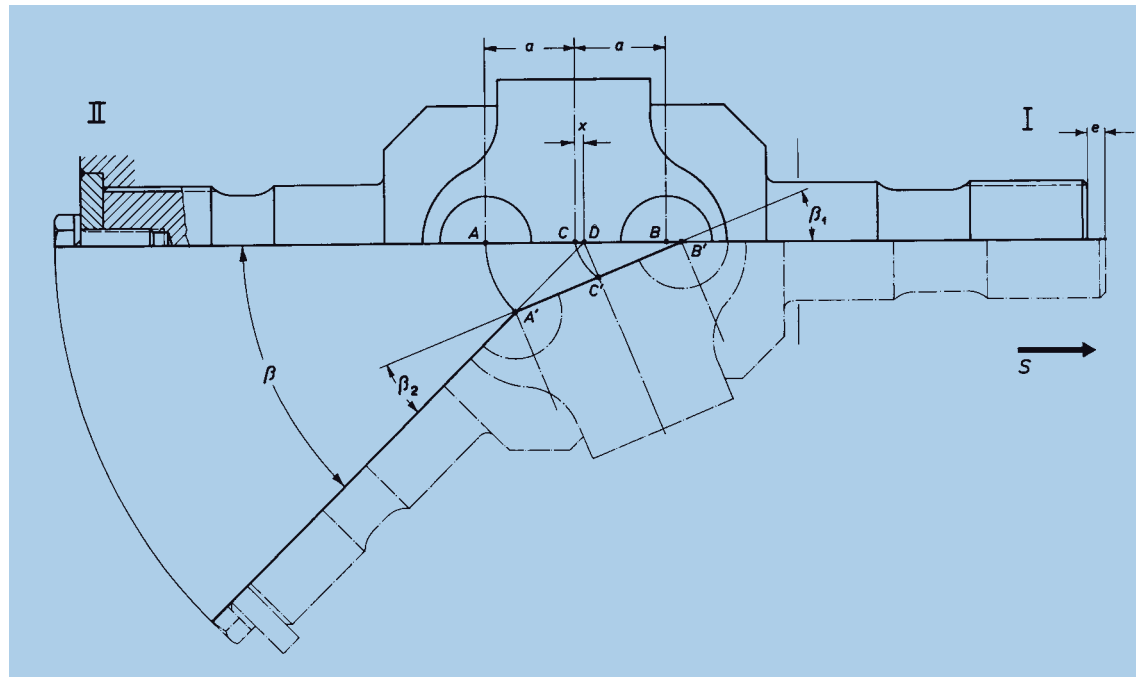

- A = } Joint pivot point
- B = }
- C = center of the double joint
- D = rotation pin center
- a = distance of a joint point from the center of the double joint
- e = axial movement of floating shaft
- X = center offset on installation
- β_x = uniform motion angle (synchronous)
- β = total deflection angle
- β_1 = } deflection angle of each individual joint
- β_2 = }

7.2 Center offset value **x** and max. slide movement **e**

$$X = \frac{a}{\cos \frac{\beta_x}{2}} - a$$

The center offset **X** required for smooth output can be derived from distance **a** and synchronous motion angle β :

Calculated center offset value **X** for individual joint sizes:

Series 0.400, synchronous motion angle $\beta_x = 35^\circ$

Joint size	0.408	0.409	0.411	0.412
Deflection angle β°	50	50	50	50
x [mm]	1,5	1,7	2,0	2,2

Series 0.500, synchronous motion angle $\beta_x = 32^\circ$

Joint size	0.509	0.510	0.511	0.512	0.513	0.514	0.516	0.518
Deflection angle β°	42 47	50	42 47	42 47	42 47	42	42 47	42 47
x [mm]	1,3 1,3	1,6	1,5 1,6	1,6 1,7	1,7 1,8	2,0	2,1 2,2	2,2 2,3

Sliding motion **e** at deflection angle β , and also as a function of distance **a** and uniform motion angle β_x , can be calculated as follows:

$$e = 2a \left(\frac{\sin^2 \frac{\beta}{2} + \sqrt{\cos^2 \frac{\beta_x}{2} - \sin^2 \frac{\beta}{2} \cdot \cos^2 \frac{\beta}{2}}}{\cos \frac{\beta_x}{2}} - 1 \right)$$

Max. slide motion **e** for the individual joint sizes:

Series 0.400, synchronous motion angle $\beta_x = 35^\circ$

Joint size	0.408	0.409	0.411	0.412
Deflection angle β°	50	50	50	50
e [mm]	6,5	7,2	8,3	9,2

Series 0.500, uniform synchronous motion angle $\beta_x = 32^\circ$

Joint size	0.509	0.510	0.511	0.512	0.513	0.514	0.516	0.518
Deflection angle β°	42 47	50	42 47	42 47	42 47	42	42 47	42 47
e [mm]	4,5 6,0	7,9	5,2 6,9	5,8 7,8	6,1 8,1	7,0	7,3 9,7	7,8 10,5

7.3 Sizing of double joint shafts

Max. possible torque should be used for determining the required joint size. This could be the input torque, calculated from prime mover output, gear ratio and power distribution, or also the tire slippage torque, derived from allowable axle loading, static tire radius and coefficient of friction. The lower of the two values represents the maximum operating torque which should be used for determining the

proper joint size. The double joint shaft selected this way will have adequate life expectancy, since the time percentage of maximum loading is usually low.

7.4 Loads on the shaft bearing

Double joint shafts, when not centered, must have a bearing support at both shaft halves right next to the joint with one shaft half fixed axially and the other floating axially. When torque is being transmitted, additional forces occur which must be taken into account when sizing the bearings.

7.5 Torque capacity of double joints as a function of deflection angle

Under torque, different force conditions exist at the joint spider pins and center piece with the double joint in an angled position than in a straight position. The reason for this is that the torque to be transmitted is not distributed evenly over the joint spider pins any longer. Also, as mentioned in Chapter 5, an additional moment occurs. This additional moment must be combined with the torque to be transmitted.

This resulting moment leads to higher compression loads and to a larger bending stress within the joint spider pins. The diagram below allows to take these factors into account. It shows the percentage the maximum allowable torque must be reduced in relation to the deflection angle.

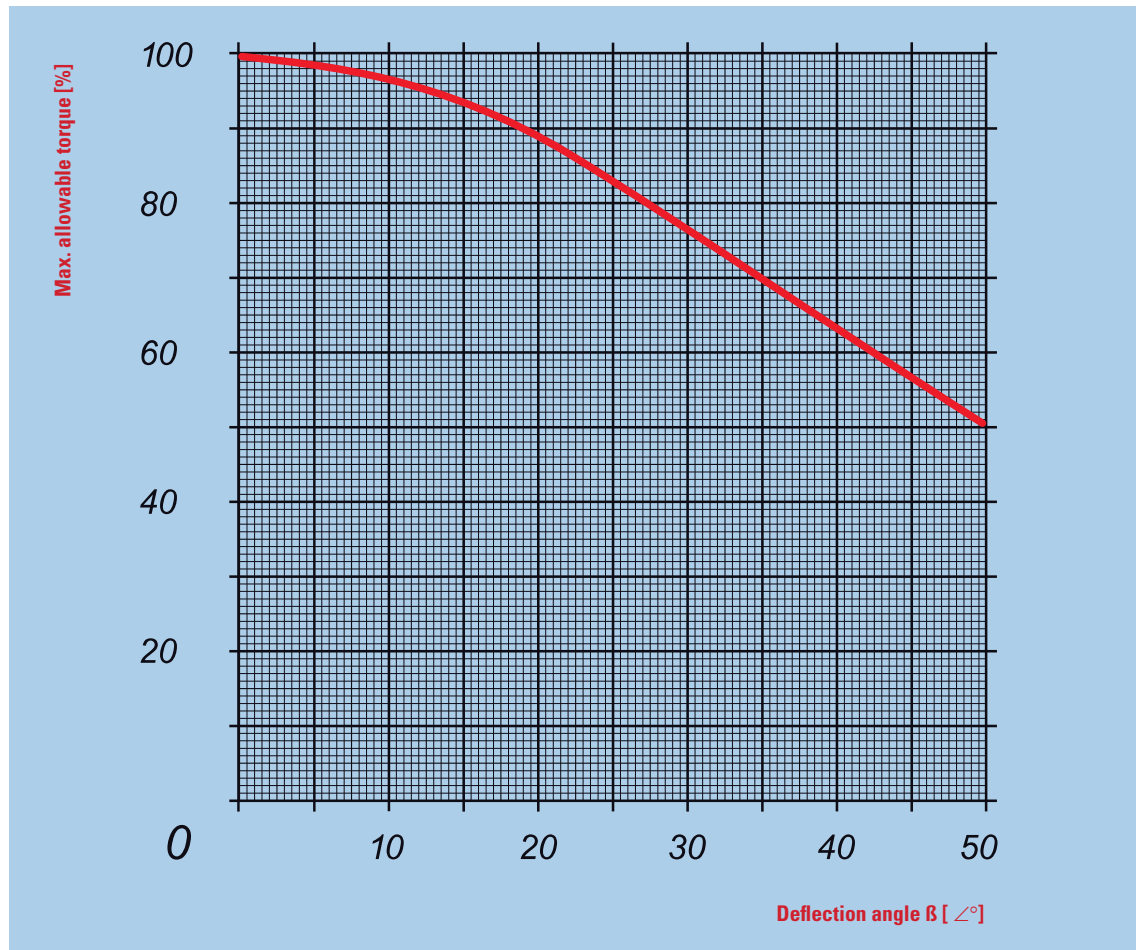

8. Hints for the application of pin and block cardan joints, ball and socket cardan joints

Torque calculation for needle bearing equipped precision cardan shafts, pin and block cardan joints, ball and socket cardan joints, single

The values $M_{d,max}$ listed in the diagram represent limit values that may not be exceeded. They are admissible to the full extent only at small rotation speed and minor angle of deflection respectively during intermittent operation.

The transmissible torque varies depending on the size of the angle of deflection.

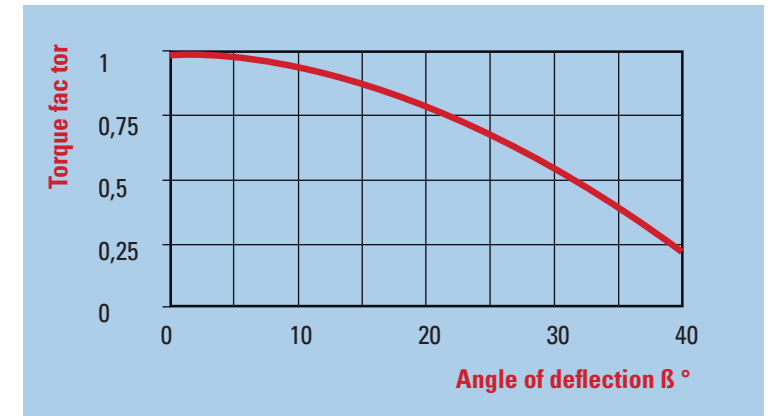

Needle bearing equipped precision cardan joints

Permitted max. operation moments of the needle bearing equipped precision cardan joints (Torque in Nm)..

Joint type	Speed (r.p.m.)						
	250	500	1000	2000	3000	4000	5000
0.616	11	10	8	6	5,5	5,1	4,8
0.620	28	25	19	15	14	12,5	12
0.625	35	30	25	20	18,5	17	16
0.632	70	60	50	40	37	34	32
0.640	150	130	100	80	74	68	64
0.650	220	190	150	120	110	100	95
0.663	450	400	310	250	220	200	190

Pin and Block cardan joint, Ball and socket cardan joint, single

The empirical formula on the right can be used for the rolled calculation of the required joint size.

At	$M_{d,max}$	Speed x bending angle ≤ 500
At 0,5 x	$M_{d,max}$	Speed x bending angle ≤ 5000

Recommendations for maintenance

An adequate lubrication shall be ensured for universal and ball-and-socket joints in permanent operation. Where drip oiling is not feasible, the joints have to be once daily lubricated (for lubricating points see arrow). Joints may also be enveloped in bellows; such bellows for these tow joint types may be ordered from us.

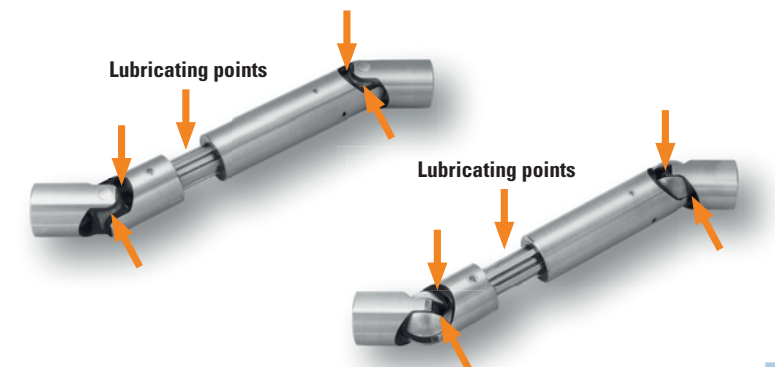

For utilization of cardan shafts under extreme climatical conditions (high and low temperatures) consult us first.

9. Transport and storage – installation information

Our universal drivelines are delivered ready for installation. If not otherwise specified by the customer, they are balanced dynamically at $n = 2000$ RPM according to classification Q 16 of the VDI recommendation 2060.

9.1 Transport and storage

To retain the high degree of balance, the drivelines must be protected during transportation or storage from blows or jolts. It is recommended to transport them in horizontal position. When transporting them vertically, appropriate measures must be taken to avoid separation of the driveline halves. A horizontal position is also preferred for storage of the driveline, since doing so eliminates tipping over and possible damage. Never store drivelines on the floor, but if possible, on wooden shelves. In case of prolonged storage, blank metal parts must be checked for corrosion, and if necessary, treated again with a corrosion inhibiting oil.

9.2 Installation

Before installing drivelines, all traces of rust inhibitor, dirt and grease must be removed from the flange surfaces to preserve the coefficient of friction vital for torque transmission.

Drivelines should not be separated at the splines and the halves interchanged, otherwise the quality of balance is greatly impaired. For the same reason, balance plates should not be removed. Prior to installing drivelines, it must be checked that they are assembled correctly, which means that the marking arrows on the splined shaft and splined hub must face each other (See also notation on Page 170).

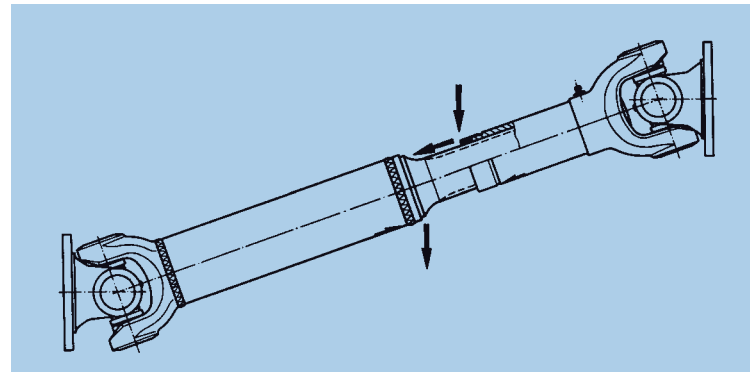

These drivelines should be arranged such that the spline, whenever possible, is protected from dirt and moisture. As a rule, this means installing the driveline according to the sketch above, where the spline seal points downwards so that spray water hitting it runs away from the spline.

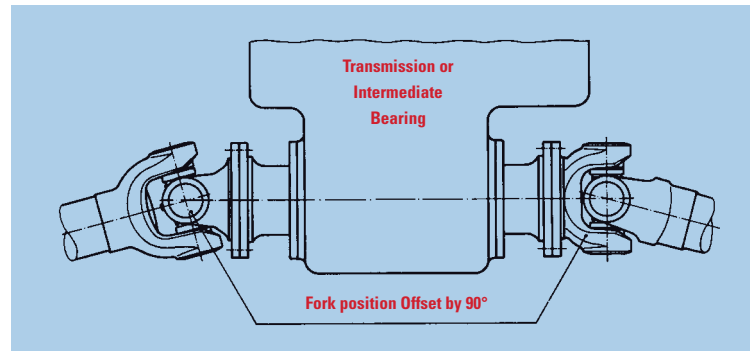

If two or more drivelines are arranged in series behind each other, it is recommended that they be mounted offset to each other by 90° . Doing so will at least partially cancel the outside effect of the mass acceleration forces caused by the fluctuation motion of the driveline center parts.

The necessary bolting hardware for flange mounting can also be supplied by us on re-

quest. For bolt grades and necessary bolt torques, see page 74. When torquing down the bolts, if possible, a torque wrench should be used and the torque should be applied evenly in a crosswise pattern.

Our drivelines are delivered grease-packed, ready for installation. However, after prolonged storage, it is advisable to reapply grease before putting them into service.

10. Safety instructions and Maintenance

10.1 Safety instructions

The operator has to take corresponding safety precautions that will exclude dangers to persons and material by rotating drive shafts or their components.

- On working on the drive-shafts the **drive has to be in quiescent condition** – set down engine and secure, so that the drive can't be activated unauthorised by a third person.
- Installation, assembly and maintenance work may be performed only by **competent personnel**.
- When installing and disassembling and when transporting of the drive shafts don't reach into the joints to avoid contusions caused by **tilting flanges or components**. Take suitable measures to avoid that drive-shafts-shares **slide apart unintentionally** and cause injuries or damage.
- Fast mode or/and long shafts should be lined with protection devices like safety shackle and guard and protected against touching or point potential dangers explicitly out.
- Don't place weights onto shafts in standstill, don't place, hang or fasten tools or other objects on the shafts.

The user or operator has to observe the legal safety regulations and has to make arrangements before beginning the maintenance-work.

To avoid damages or dangers observe the following **basic information**:

- The permitted **operating speed** may not be exceeded.
- Don't exceed the permitted **angle of deflection**.
- In case of shafts with **length extension** the maximum permitted X-value may not be exceeded. It is recommended to use 1/3 of the complete length extension.
- The drive shaft has to be checked regularly for modified **running noises** and **vibrations** and if necessary to check the changing of the **joint slackness** and of the length extension in standstill.
- The **balance status** of drive shafts may not be changed.
- Don't make modifications or unauthorized repairs without the **written approval** of the manufacturer, as dangers for humans and material result and any claim of warranty becomes void.

- Drive shafts may not be cleaned with **pressure water** or **steam jet** to avoid damage of the seals and to prevent the penetration of water and dirt.
- When cleaning don't use **aggressive cleanser**.
- **Protect plastics-coated profiles** and sliding surfaces against mechanical, thermal and chemical damages. Sliding surfaces for seals have to be covered before colouring.
- The drive shafts may only be installed in fluid or solid media with written approval of the manufacturer.
- **Local heating** of the drive shafts (e. g. flame cleaning of colour residues) must not be carried out to avoid significant changes of the true running characteristics.

10.2 General maintenance information

ELBE drive shafts will be delivered as fully finished power units, are ready for use greased and balanced. To guarantee the characteristics specified in the documentation, the condition upon delivery may not be changed.

Above-average load, variations in temperature and the effect of dirt and water render it necessary to observe shorter maintenance intervals to guarantee the safe and efficient application.

The maintenance-cycle of the drive shafts depends particularly on the application conditions.

We recommend coordinating the inspection intervals of the drive shafts with the ones of other machine parts or with the service inter-

Application field Joint	control and maintenance intervals	length extension
Commercial vehicles in street application	50.000 km or 1 year	maintenance-free
Commercial vehicles in street- and territory application	25.000 km or 6 months	maintenance-free
Commercial vehicles in pure construction-site and territory application	10.000 km or 1 month	maintenance-free or 100 hours
Earth-moving and construction machines	250 operating hours or 1 month	maintenance-free or 100 hours
Stationary plant and machines construction	500 operating hours or 3 months	maintenance-free or 3 months

vals of the machine or of the vehicle.

Inspection and maintenance are required at least once a year.

10.3 Lubrication guidelines

ELBE cardan-drive-shafts are normally equipped with 3 cone-grease-nipples DIN 71412. Thereby every joint will be greased over per grease nipple, the third nipple serves for relubrication of the spline profile.

This nipple is omitted for plastic-coated length extensions.

10.3.1 Lubricants

- Temperature range -30°C up to max. +70°C: For relubrication of the drive shafts use only **lithium-saponified greases** of consistency class 2 with penetration 265/295 and drop point approx. 180°C. The lubrications may not contain **MoS₂**-additives.
- Temperature range up to approx. +250°C, (**High-temperature-version**): use HT-greases of the consistency 2. Special versions up to +250°C are partly available.
- Temperature range from approx. -60°C up to +110°C (**low-temperature-version**): use TT-greases of the consistency 1 or 2

10.3.2 Maintenance-free Cardan Shafts

- **Maintenance-free** versions of our shafts are possible in certain applications.
- However, the following **factors** in application and operating conditions are important to **consider**:
 - High ambient temperatures
 - Unfavorable angle/speed ratios
- **Furthermore, deterioration of the lubrication** needs to be considered. Since no relubrication is possible, we **recommend periodic replacement of the spider units**.

10.4 Technical information

- Before lubricating **clean grease nipples!**
- The relubrication of the spline-length-extension should be carried out **at compressed length** S_{min} or in the shortest operation status (vehicle loaded). Non-observance may result in excess axial forces.
- Air vent may not be taken off or be replaced by standard grease nipples.
- The lubricant may not be pressed in with excessive pressure or with hard lubrication impact.
- Max. permitted **lubrication pressure: 20 bar**.
- The cross units have to be relubricated over the grease nipples in the centre of the cross or on the bottom of a bearing housing of the cross. It must be ensured that grease is pressed in until it **leaks from all four seals of each bearing**.
- This is the only way to ensure that all four bearings have received fresh grease.
- Some versions of double drive-shafts are equipped with a grease nipple on the centre piece of the joint, over which both cross joints can be relubricated at the same time through lubrication ducts (**central lubrication**).
- Drive shafts that are stored more than 6 months have to be lubricated before starting.

10.5 Control information

- Fittings and connection flanges have to be checked for firm connection.
- Drive shafts should be checked in operation for abnormal noises or vibrations, to determine the cause and initiate repair work.
- Before lubrication, check the driveshaft for looseness in the joints or splines.
- The connection side of the drive shaft flanges and companion flanges must be cleaned before installation. They must not be greased or oiled.
- Corrosion inhibitors and paint residues must be thoroughly removed. Possible light transportation damage should be corrected (nicks and scratches).
- Companion flanges have to be checked for face and OD runout.