

S 500 kN
Z-500-S | translating screw

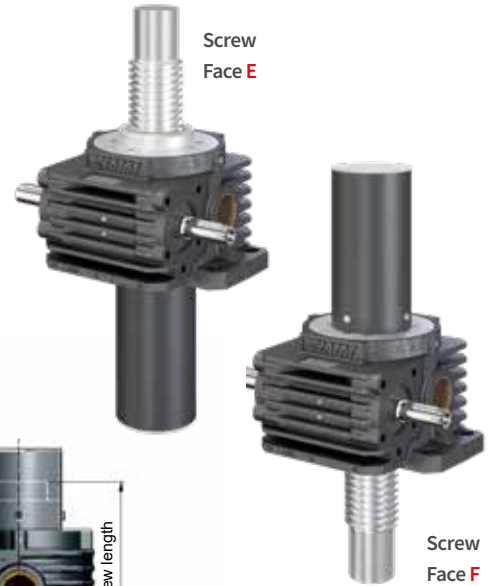

Opening for protective tube SRO

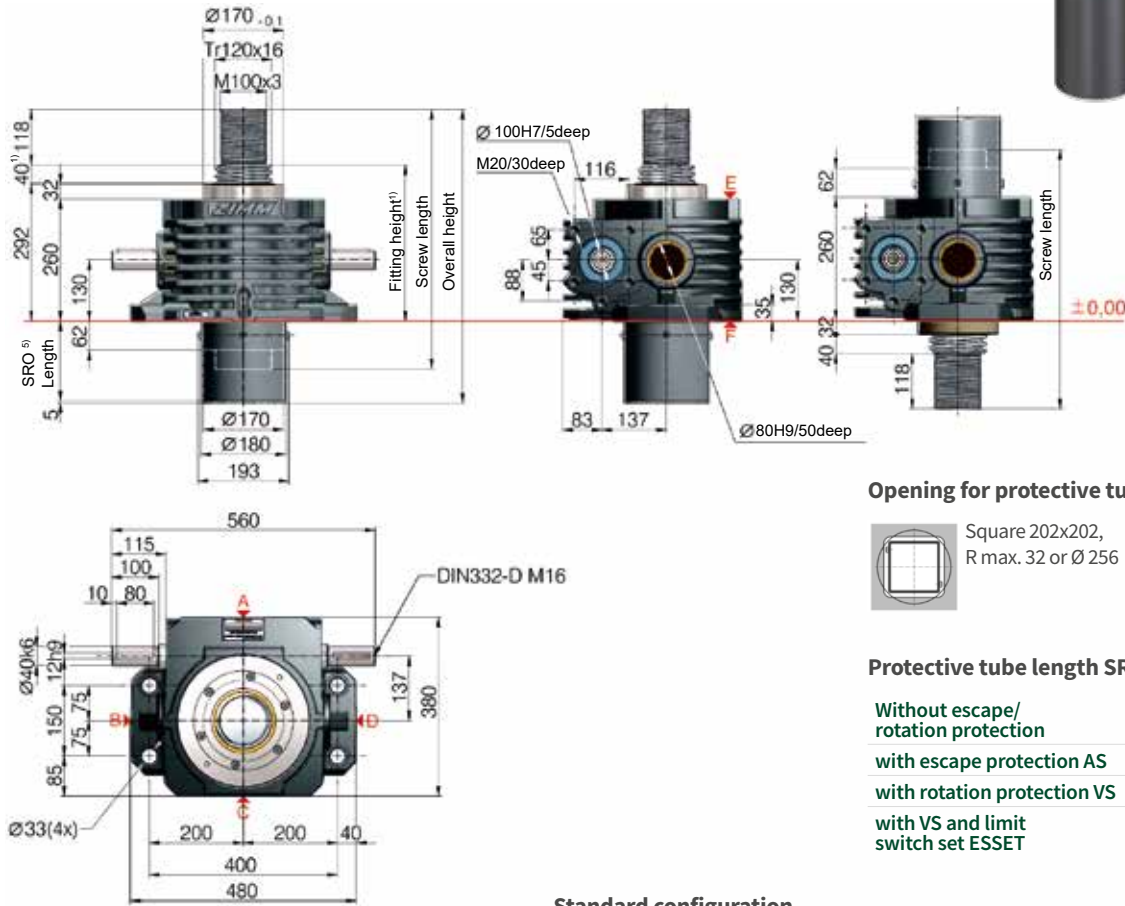
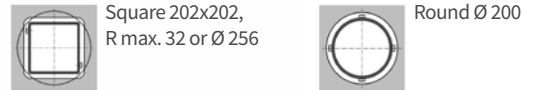

Protective tube length SRO with Tr 120x16-Screw

Without escape/rotation protection	157 + stroke	Ø 180
with escape protection AS	197 + stroke	Ø 180
with rotation protection VS	197 + stroke	□ 180 x 180
with VS and limit switch set ESSET	197 + stroke	□ 180 x 180

Standard configuration

Code	Gearbox (series)	Size	Version (variant)	Ratio	Screw	Stroke per drive shaft rotation
Z-500-SN	Z	500	S (translating screw)	N (normal) 10,66:1	Tr 120x16	1,50 mm
Z-500-SL				L (low) 32:1		0,50 mm

500 kN

Duty cycle thermal limit (S + R)

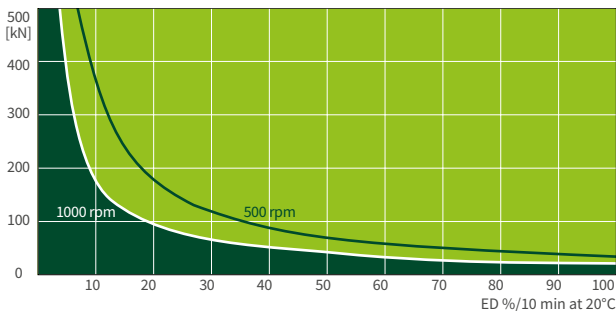

These curves are for guidance under standard industrial conditions (ambient temperature 20°C etc.) and correct maintenance (lubrication etc.). They are based on the ZIMM standard trapezoidal thread Tr 120x16. With the use of a ball screw, the operation cycles can be many times longer.

Screw jack mounting Z-Series

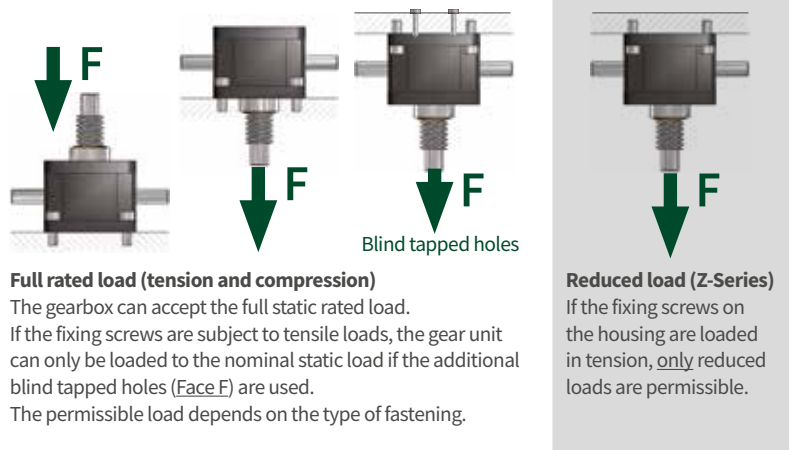

Full rated load (tension and compression)

The gearbox can accept the full static rated load. If the fixing screws are subject to tensile loads, the gear unit can only be loaded to the nominal static load if the additional blind tapped holes (Face F) are used. The permissible load depends on the type of fastening.

Reduced load (Z-Series)

If the fixing screws on the housing are loaded in tension, only reduced loads are permissible.



R 500 kN

Z-500-R | rotating screw

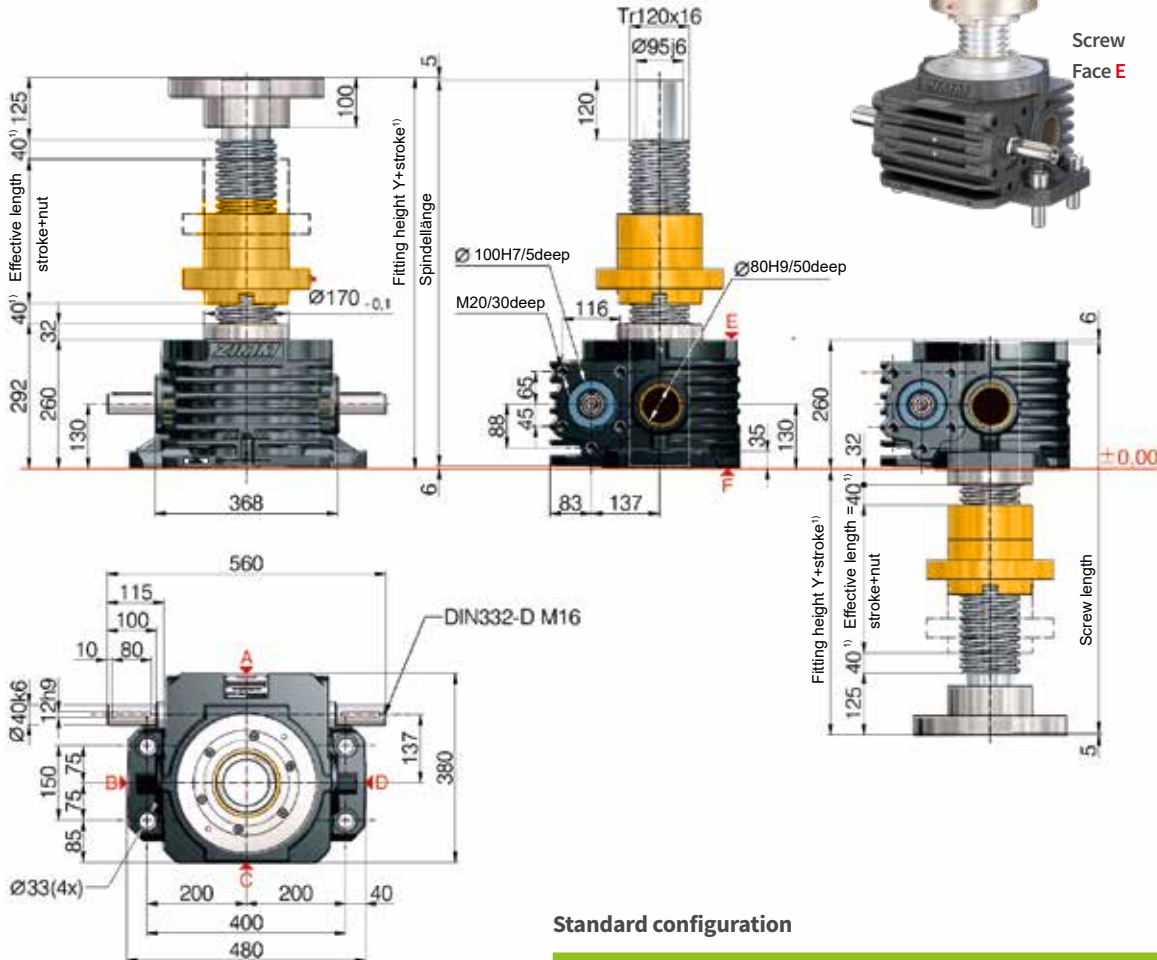

Standard configuration

Code	Gearbox (series)	Size	Version (variant)	Ratio	Screw	Stroke per drive shaft rotation
Z-500-RN	Z	500	R (rotating screw)	N (normal) 10,66:1	Tr 120x16	1,50 mm
Z-500-RL				L (low) 32:1		0,50 mm

Technical data serie Z-500-S / Z-500-R

max. compressive/tensile force, static:	500 kN (50 t)
max. compressive/tensile force, dyn.:	see duty cycle curves
Input speed:	1000 rpm / max. 1000 rpm (depending on the load and duty cycle)
Screw size standard:	Tr 120x16 ²⁾
Gear ratio:	10,66:1 (N) / 32:1 (L)
Housing material:	GGG-50, corrosion-resistant
Worm shaft:	steel, case-hardened, ground
Weight of screw jack body:	168 kg
Weight of screw/m:	77 kg
Gearbox lubrication:	synthetic gear oil
Screw lubrication:	grease lubrication
Gearbox operating temperature:	max. 60°C, higher on request
Moment of inertia:	N: 310,2 kg cm ² / L: 127,8 kg cm ²
Input torque (at 1000 rpm):	max. 408 Nm (N) / max. 170 Nm (L)
Drive-through torque:	max. 1940 Nm
Drive torque M _G (Nm):	F (kN) x 1,24 ^{3,4)} (N-Normal) F (kN) x 0,50 ^{3,4)} (L-Low)
Breakaway torque:	Drive torque M _G x 1,5

Make a plan to keep a safe distance of at least 40 mm between gearbox and nut or between nut and threaded end!

Detailed calculation of the fitting dimensions (bellows, screw, protective tube...) can be conveniently determined with our online configurator: www.zimm.com

Important information:

- 1) If a bellows, spiral spring or double pitch is used more fitting space is required
- 2) Tr 120x16 is standard, also available: double-pitch, INOX, left-handed, increased screw Tr 140x20 (only for the R-Version)
- 3) factor includes efficiency, ratio and 30% safety
- 4) for a 16 mm screw pitch
- 5) to calculate the length of our protective tube length SRO simply use our online configurator: www.zimm.com