

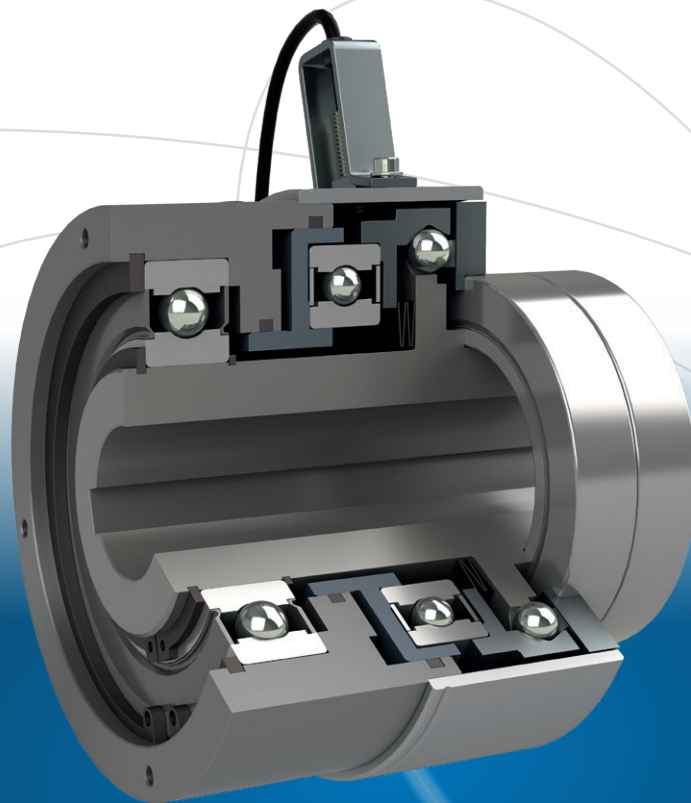

*your reliable partner*



**EAS<sup>®</sup>-Sp**  
**EAS<sup>®</sup>-Sm/Zr**

## Contents

	Page
Summary of constructional designs EAS <sup>®</sup> -Sp / EAS <sup>®</sup> -Sm / EAS <sup>®</sup> -Zr	3
<b>EAS<sup>®</sup>-Sp pneumatically controllable torque limiting clutches</b>	
<b><i>Torque range: 4 to 2500 Nm</i></b>	
Description	4
Data sheets	
• EAS <sup>®</sup> -Sp standard	6
• EAS <sup>®</sup> -Sp torsionally rigid	7
Technical explanations	8
Installation examples	9
<b>EAS<sup>®</sup>-Sm / EAS<sup>®</sup>-Zr electromagnetically controllable torque limiting clutches</b>	
<b><i>Torque range: 6 to 375 Nm</i></b>	
Description	10
Data sheets	
• EAS <sup>®</sup> -Sm/EAS <sup>®</sup> -Zr standard	12
• EAS <sup>®</sup> -Sm/EAS <sup>®</sup> -Zr with cover	12
• EAS <sup>®</sup> -Sm/EAS <sup>®</sup> -Zr torsionally rigid	13
Technical explanations	14
Limit switch installation	14
Installation examples	15
<b>Electrical accessories</b>	
EAS <sup>®</sup> -Sp control unit <span style="color: red;">No longer available</span>	16
EAS <sup>®</sup> -Sm / EAS <sup>®</sup> -Zr control unit <span style="color: red;">No longer available</span>	19
Limit switch	
• Mechanical operation	22
• Contactless, magnetic field-resistant	23

## Total Quality Management

### Product Quality

Every delivery which leaves our firm has been subjected to a careful quality inspection, meaning that you are able to rely 100 % on *mayr*<sup>®</sup> products. If required, we pre-adjust our clutches and brakes accurately to the requested values and confirm the product characteristics with an Inspection Report.

### Quality Management

*mayr*<sup>®</sup> uses the term quality to describe its products and services. Certification of our quality management confirms the quality-consciousness of our colleagues at every level of the company.

Our integrated management system is certified according to **DIN EN ISO 9001:2015 (Quality)** and **DIN EN ISO 14001 (Environment)** and complies with the **OHSAS 18001/OHRIS (Occupational Health and Safety)** demands.

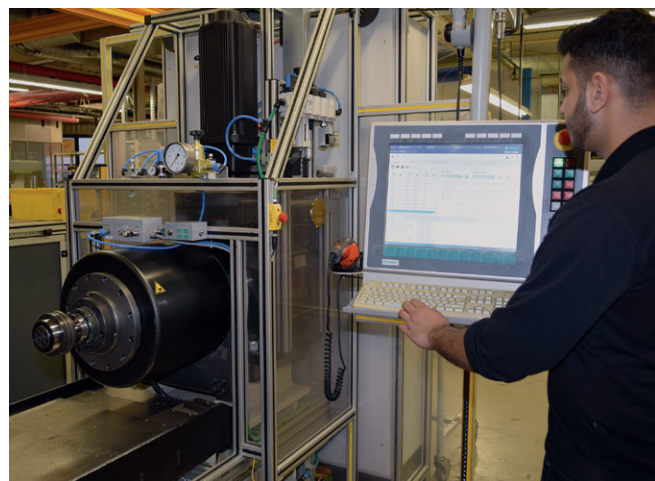
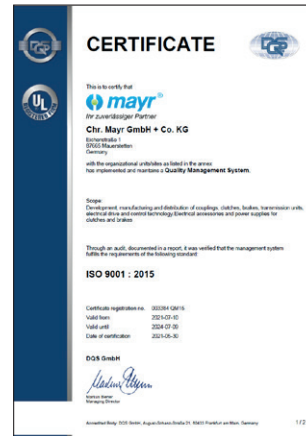

All products are subject to comprehensive inspections and tests regarding loads. Only after having passed the strongest long-time tests and when they fully meet all the technical requirements and proof their reliability they are included in our delivery programme.

## Your advantages when using electromagnetically or pneumatically controllable torque limiting clutches with switching function:

- The clutches precisely limit the torque to the value determined by the supply current or air pressure and reduce damage, costly repairs and downtimes in case of overload.
- During operation the transmittable torque can be exactly adapted to the production cycle via the current level or the pneumatic pressure. Your machine is optimally protected in every production phase.
- The immediate readiness for service in the event of a failure reduces the downtimes of your system to a minimum.
- The clutches are remotely controllable by using current or air pressure as actuating or regulating mediums and can be included in complex control systems: a decisive advantage for usage in automated machinery.
- Specifically designed control units ensure easy operation and guarantee optimum usage of the full functional features of the clutches.
- The comprehensive range with the wide variety of functional principles and constructional variations offer a suitable design for your application.

## Summary of constructional designs EAS®-Sp / EAS®-Sm / EAS®-Zr

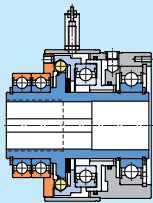
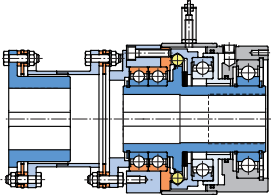
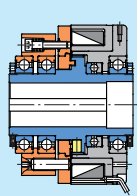
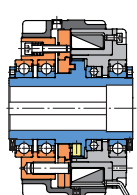
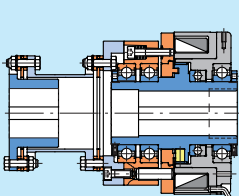
<b>EAS®-Sp Standard</b>		Torque: 4 to 2500 Nm  Sizes 01 to 5 Type 450.125._	<ul style="list-style-type: none"> <li>• Clutch disconnects input and output in case of overload or via an external control.</li> <li>• Synchronous re-engagement via compressed air after each full turn:               <ul style="list-style-type: none"> <li>- Re-engagement EAS®-Sp after 360°</li> </ul> </li> <li>• Backlash-free torque transmission</li> </ul> See installation examples, Figs. 1 to 3, page 9	<b>Page 6</b>
<b>EAS®-Sp Torsionally rigid</b>		Torque: 15 to 2500 Nm  Sizes 0 to 5 Type 456.125.8	<ul style="list-style-type: none"> <li>• Clutch/ROBA®-D torsionally rigid flexible all-steel coupling combination</li> <li>• Coaxial shaft connection for compensation of misalignments</li> </ul>	<b>Page 7</b>
<b>EAS®-Sm EAS®-Zr Standard</b>		Torque: 6 to 375 Nm  Sizes 0 to 4 Type 400.036.0 Type 400.038.0	<ul style="list-style-type: none"> <li>• Electrical torque limiting clutch with switching function Torque adjustment via an adjustable DC voltage</li> <li>• Clutch disconnects the drive in case of overload or when the current is switched off:               <ul style="list-style-type: none"> <li>- Re-engagement EAS®-Sm after 360°</li> <li>- Re-engagement EAS®-Zr after 15°</li> </ul> </li> <li>• Flange construction for assembly of pulley, toothed wheels etc., with any additional support bearing supplied by the customer</li> </ul>	<b>Page 12</b>
<b>EAS®-Sm EAS®-Zr with cover</b>		Torque: 6 to 375 Nm  Sizes 0 to 4 Type 400.036.2 Type 400.038.2	<ul style="list-style-type: none"> <li>• The cover prevents contamination of the air gaps between the magnetic part and the armature disk, and between the armature disk and the transmission flange.</li> <li>• Also the cover serves for mounting a contactless limit switch (proximity switch, see pages 14 and 23).</li> </ul> See installation example, Fig. 7, page 15	<b>Page 12</b>
<b>EAS®-Sm EAS®-Zr Torsionally rigid</b>		Torque: 6 to 375 Nm  Sizes 0 to 4 Type 436.036._ Type 436.038._	<ul style="list-style-type: none"> <li>• Clutch/ROBA®-D torsionally rigid flexible all-steel coupling combination</li> <li>• Coaxial shaft connection to compensation of misalignments</li> </ul> See installation example, Fig. 8, page 15	<b>Page 13</b>

## The cyclic, pneumatically switchable and controllable torque limiting clutch EAS<sup>®</sup>-Sp

- Simple attachment of the drive elements
- Low mass moment of inertia
- Long service life and maintenance free
- High switch-off accuracy
- Integrated mechanically protected limit switch

### Connection for control unit

- Motionless compressed air supply
- ON/OFF switching function, multi-start function
- Releases in case of overload
- Controllable operating pressure
- Indication possibility of the functional condition

### Integrated limit switch

- Extremely short switch-off times
- In case of overload, the limit switch detects the axial disengaging movement of the control element quickly and precisely.
- The limit switch emits a signal to release the clutch and to disconnect the drive or for further control functions.
- Mechanical protection

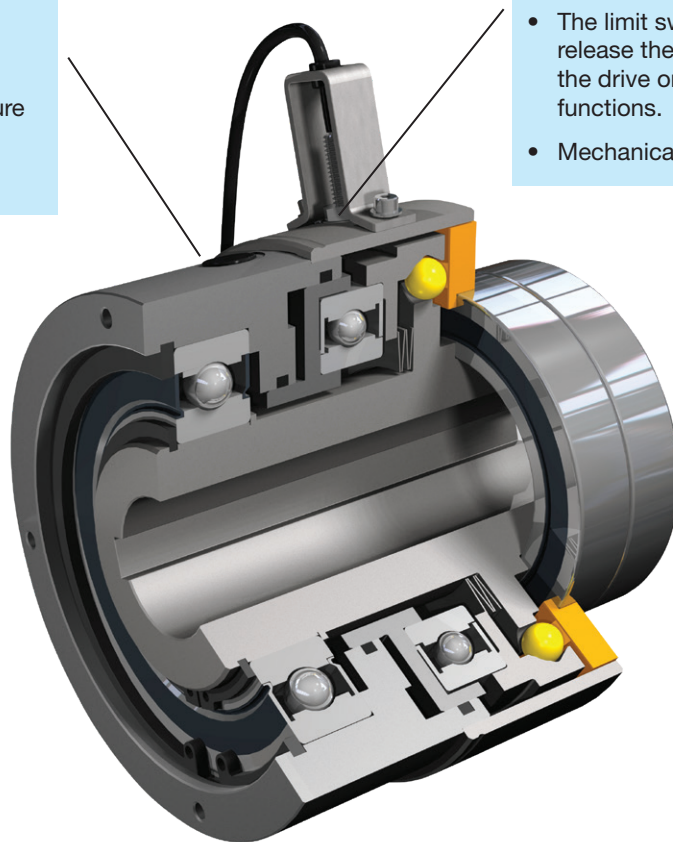

### Torque transmission and limitation

- The limit torque is determined by the existing pressure.
- Controllable torques are transmitted from the hub to the pressure flange and further to the output element via the patented backlash-free principle.
- When the limit torque is exceeded, the controlled pressure is exceeded. The limit switch is damped due to the axial movement of the control element. Input and output are disconnected.

### Output flange

- The corresponding output element (toothed wheel, pulley etc.) can be attached easily and precisely onto the pressure flange.
- The double bearing also allows the installation of wide output elements.
- Precise running accuracy



The screw quality and the tightening torque for the fixing screws of the drive element are to be selected so that the set limit torque can be safely transmitted using frictional locking.

## The backlash-free principle

The backlash-free torque transmission:

- Balls in radially and axially arranged recesses on the hub and on the pressure flange.
- The balls are pressed simultaneously into recesses of the hub and pressure flange, and therefore transmit the torques backlash-free in both rotational directions, also in case of reverse rotational direction.

## The functional principle

1. Overload function:

During operation, the clutch transmits the torque determined by the pneumatic pressure. When the torque is exceeded (due to overload) the clutch disengages, input and output are disconnected.

Simultaneously, the integrated limit switch (PNP NC contact) is damped and emits an impulse to the EAS<sup>®</sup>-Sp control unit. The clutch is de-pressurized or the drive is switched off.

2. Switching function:

The clutch can be switched pneumatically.

The torque is transmitted from input to output when the clutch is pressurized.

The clutch and therefore also the drive can be switched on or switched off via the pneumatic system.

3. Control function:

The limit torque for overload on the clutch can be adjusted continuously via the compressed air supply and can be changed during operation.

## Application of the EAS<sup>®</sup>-Sp torque limiting clutch

- In all kinds of automated machines
- With constantly changing operating conditions
- With changing cycles and cycle speeds

## Use of the EAS<sup>®</sup>-Sp torque limiting clutch

- In packaging machinery
- In filling machinery
- In printing machinery
- In washing/cleaning machines
- In materials handling equipment
- In general machine construction

Years of experience in the field of torque limiting clutches, and consistent improvement and development of our products allow us to offer you the optimum clutch for your particular application.

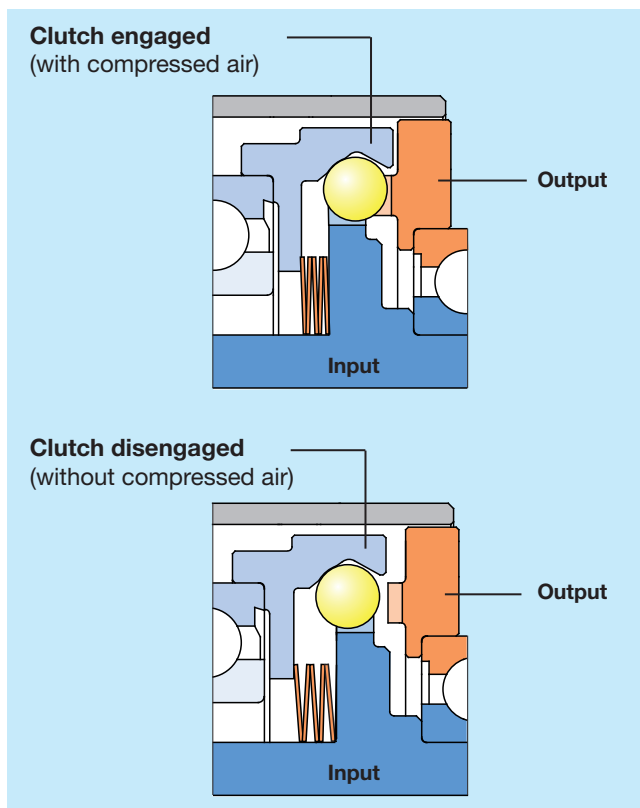

**EAS®-Sp  
Standard**

**Type 450.125.\_  
Sizes 01 to 5**

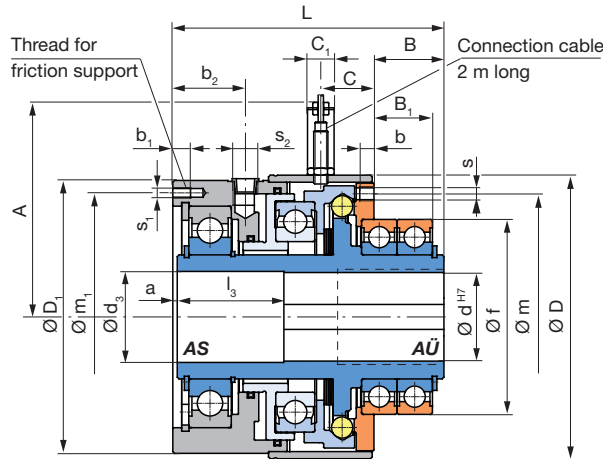

Limit switch is included in the delivery.

Technical Data			Size						
			01	0	1	2	3	4	5 <sup>2)</sup>
Limit torque for overload	$M_G$	[Nm]	4 – 40	15 – 75	25 – 150	50 – 200	100 – 500	200 – 1000	500 – 2500
Max. speed <sup>1)</sup>	$n_{max}$	[rpm]	5000	4000	2500	2000	2000	1500	500
Mass moment of inertia with $d_{max}$	Hub side	$I$	0.280	0.562	2.127	4.887	10.375	34.797	199.991
	Flange side	$I$	0.180	0.345	0.904	2.109	5.018	16.141	91.811
Weight with $d_{max}$	$m$	[kg]	2.5	3.7	7	9.7	15	29.5	82

The operating pressure of the clutch ranges between 1 and 6 bar; you can find the exact data in the diagram, page 8.

Dimensions [mm]	Size						
	01	0	1	2	3	4	5
A	81	88	101	108	123	143	186
a	0	1	1.5	2	2.5	2	5
B	15	28	33.5	36	39.5	47	64
B <sub>1</sub> <sup>3)</sup>	11	24	28	30	33	40	54
b	5.5	5.5	6.5	8	8	11	15
b <sub>1</sub>	10	8	8	10	10	12	15
b <sub>2</sub>	23.5	30	36.5	39	41	52	68
C	18.5	18.5	23.5	28.5	30	37.5	51.5
C <sub>1</sub>	- <sup>4)</sup>	15	15	15	15	15	15
D	76	90	115	130	160	200	285
D <sub>1</sub>	72	90	112	130	154	191	275

Dimensions [mm]	Size						
	01	0	1	2	3	4	5
d <sub>3</sub>	23	23	36	43	51	66	97
f <sub>HS</sub> <sup>5)</sup>	47	62	80	95	110	140	200
L	87	105	126	135	153	185	260
l <sub>3</sub>	30	40	50	55	60	70	100
m	56	72	92	110	139	172	250
m <sub>1</sub>	65	82	102	122	140	178	256
s	6 x M5	6 x M5	6 x M5	6 x M6	6 x M8	6 x M10	6 x M12
s <sub>1</sub>	4 x M5	4 x M4	4 x M5	4 x M5	4 x M6	4 x M8	4 x M10
s <sub>2</sub>	G 1/8"	G 1/8"	G 1/8"	G 1/8"	G 1/4"	G 1/4"	G 1/4"

We reserve the right to make dimensional and constructional alterations.

- 1) The speed for re-engagement or for synchronous switching operation depends on the mass to be accelerated and the load torque (see "Technical Explanations" page 8).
- 2) Size 5 not in stock
- 3) Mounting tolerance + 0.1
- 4) Without initiator guard bracket
- 5) Tolerance user-side H7
- 6) The position of the keyway to the mounting bore "s" in the pressure flange is not defined. Defined position available on request.

Bores [mm]	Size						
	01	0	1	2	3	4	5
d <sub>min</sub> DIN 6885/1	10	12	15	20	20	25	38
d <sub>max</sub> DIN 6885/1	20	22	35	42	50	65	95

**Order Number**

__ / 4 5 0 . 1 2 5 . __ / __ / __ / __				
▲	▲	▲	▲	▲
<b>Sizes</b> 01 to 5	for Sizes 0 – 5 for Size 01, torque $M_G = 8 - 40$ Nm for Size 01, torque $M_G = 4 - 20$ Nm	<b>0</b> <b>H</b> <b>L</b>	Hub bore $\varnothing d^{H7}$	Keyway <sup>6)</sup> acc. DIN 6885/1
				<b>AS</b> Counterbore stator element-side <b>AÜ</b> Counterbore transmission flange-side

**EAS®-Sp**  
**Torsionally rigid**

**Type 456.125.8**  
**Sizes 0 to 5**

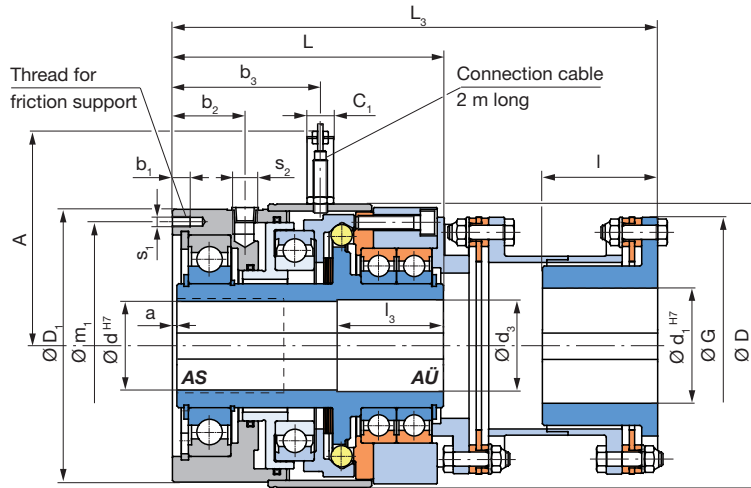

Limit switch is included in the delivery.

Technical Data			Size					
			0	1	2	3	4	5 <sup>2)</sup>
Limit torque for overload	$M_G$	[Nm]	15 – 75	25 – 150	50 – 200	100 – 500	200 – 1000	500 – 2500
Max. speed <sup>1)</sup>	$n_{max}$	[rpm]	4000	2500	2000	2000	1500	500
Nominal torques, torsionally rigid coupling	$T_{KN}$	[Nm]	50	100	200	400	1000	2500
Mass moment of inertia with $d_{max}$	Hub side	$I$ [10 <sup>-3</sup> kgm <sup>2</sup> ]	0.562	2.127	4.887	10.375	34.797	199.991
	Flexible side	$I$ [10 <sup>-3</sup> kgm <sup>2</sup> ]	3.795	5.426	17.592	35.087	111.144	299.397
Weight with $d_{max}$	$m$	[kg]	6	10	15.8	24	48.5	114.5

The operating pressure of the clutch ranges between 1 and 6 bar; you can find the exact data in the diagram, page 8.

Dimensions [mm]	Size					
	0	1	2	3	4	5
A	88	101	108	123	143	186
a	1	1.5	2	2.5	2	5
$b_1$	8	8	10	10	12	15
$b_2$	30	36.5	39	41	52	68
$b_3$	58.5	69	70.5	83.5	100.5	144.5
$C_1$	15	15	15	15	15	15
D	90	115	130	160	200	285
$D_1$	90	112	130	154	191	275

Dimensions [mm]	Size					
	0	1	2	3	4	5
$d_3$	23	36	43	51	66	97
G	92	102	128	145	180	215
L	105	126	135	153	185	260
$L_3$	169	194	219	247	306	421
l	40	45	55	65	80	90
$l_3$	40	50	55	60	70	100
$m_1$	82	102	122	140	178	256
$s_1$	4xM4	4xM5	4xM5	4xM6	4xM8	4xM10
$s_2$	G 1/8"	G 1/8"	G 1/8"	G 1/4"	G 1/4"	G 1/4"

We reserve the right to make dimensional and constructional alterations.

Bores [mm]	Size						
	0	1	2	3	4	5	
d	$d_{min}$ DIN 6885/1	12	15	20	20	25	38
	$d_{max}$ DIN 6885/1	22	35	42	50	65	95
$d_1$	$d_{1min}$ DIN 6885/1	8	12	15	20	26	38
	$d_{1max}$ DIN 6885/3	38	45	-	-	-	-

1) The speed for re-engagement or for synchronous switching operation depends on the mass to be accelerated and the load torque (see "Technical Explanations" page 8).

2) Size 5 not in stock

**Order Number**

_ / 4 5 6 . 1 2 5 . 8 / _ / _ / _ / _ / _					
▲	▲	▲	▲	▲	▲
Sizes 0 to 5	Hub bore $\varnothing d^{H7}$	Keyway <sup>6)</sup> acc. DIN 6885/1	Hub bore $\varnothing d_1^{H7}$	Keyway <sup>6)</sup> acc. DIN 6885/1 6885/3	AS Counterbore stator element-side AÜ Counterbore transmission flange-side

Example: Order Number 1 / 456.125.8 / 30 / 6885/1 / 43 / 6885/3 / AÜ

## Technical Explanations

### Operating speeds

The speeds mentioned on pages 6 and 7 are operating speeds which refer to the engaged condition of the clutch.

The re-engagement speed of the EAS®-Sp clutches depends on the corresponding clutch size or mass moments of inertia of the flanged drive element. Re-engagement or connection of the clutch under load should not take place.

**Please contact our application engineers regarding your special application.**

### Torque adjustment

Adjusting and altering the torques can be accomplished by altering the air pressure. The torque capacity is proportional to the air pressure (see also "Torque curves static" below).

It is recommended to maintain a constant compressed air pressure. Using the EAS®-Sp control unit enables the torque to be simply and rapidly adjusted.

### Electrical connection

The clutch together with the integrated limit switch can be connected via the EAS®-Sp control unit.

You can find Technical Data and Explanations on the control unit from page 16 onward.

### Securing the clutch onto the shaft

The EAS®-Sp clutches are supplied with finish bores and keyways according to DIN 6885. The clutch is mounted onto the shaft using a suitable device, and axially secured using a press cover (Fig. 1, page 9), set collars or locking rings.

EAS®-Sp clutches can be supplied with a cone bushing (Fig. 2, page 9) or shrink disk (Fig. 3, page 9) as special designs.

**Please contact our place of manufacture.**

### Attaching the friction support

The stator element of the clutch must not rotate.

A support is required to absorb the low friction torque caused by the roller bearings of the stationary stator element.

The friction support must not transmit any appreciable forces (distortions) onto the clutch.

### Torque curves static



The values stated in the diagrams are reference values, which are subject to certain tolerances.

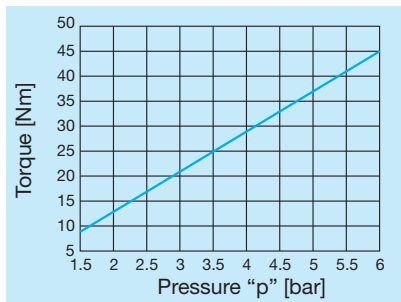

EAS®-Sp 01/450.125.H

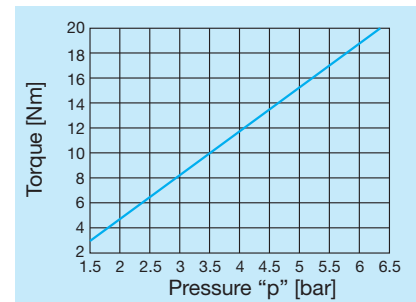

EAS®-Sp 01/450.125.L

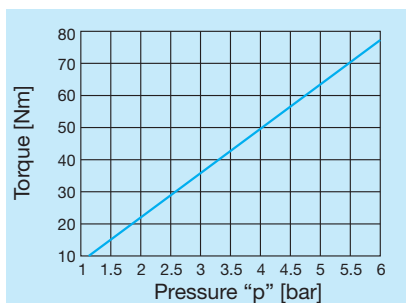

EAS®-Sp 0/45\_.125\_..

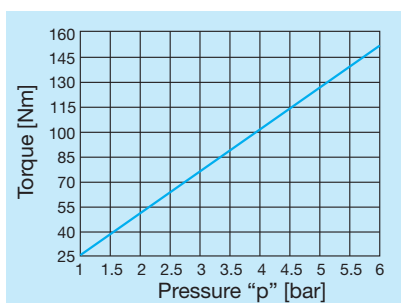

EAS®-Sp 1/45\_.125\_..

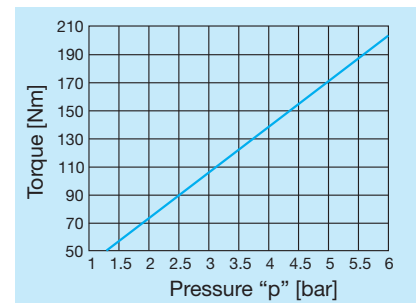

EAS®-Sp 2/45\_.125\_..

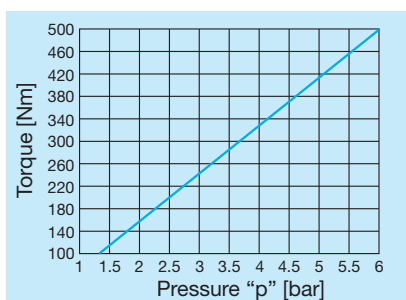

EAS®-Sp 3/45\_.125\_..

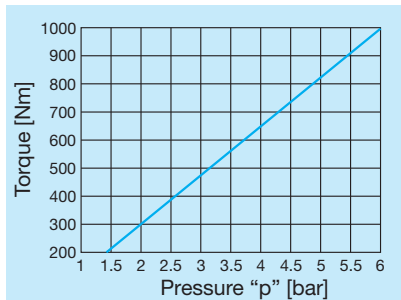

EAS®-Sp 4/45\_.125\_..

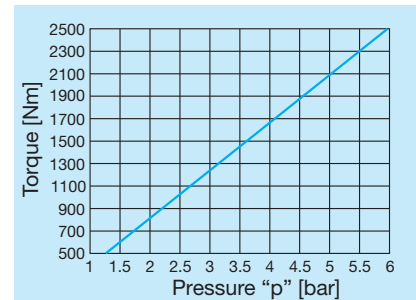

EAS®-Sp 5/45\_.125\_..



## Switching examples

### 1-pressure system

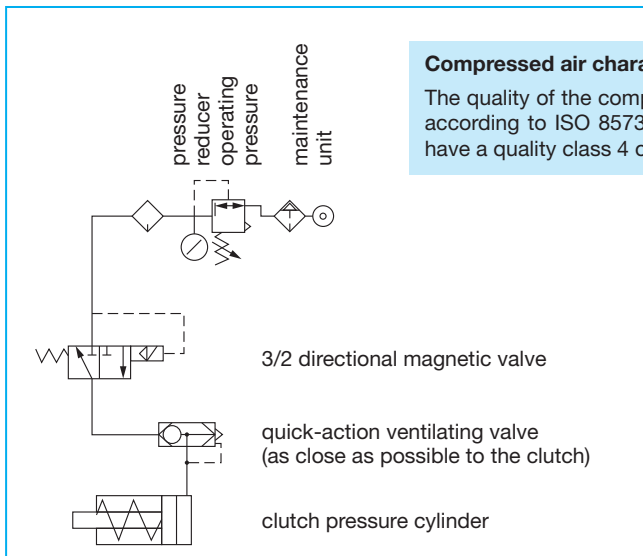

**Compressed air characteristics**  
The quality of the compressed air according to ISO 8573 -1 should have a quality class 4 or higher.

### 2-pressure system

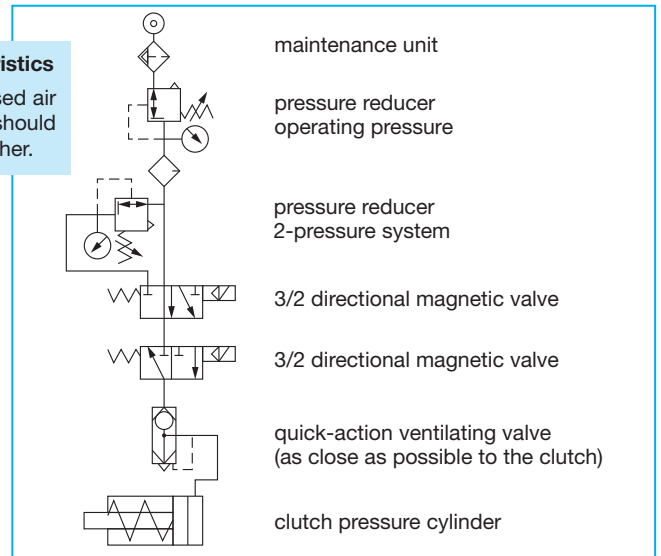

## Installation examples

### EAS<sup>®</sup>-Sp clutch used in textile machines

The EAS<sup>®</sup>-Sp clutch is mounted onto the shaft end of a draw-off roll.

The clutch is axially secured via a press cover and a hexagon head screw, screwed into the threaded centre hole of the shaft.

The friction support absorbs the frictional torque of the roller bearings between the stator element and hub and stops the stator element from rotating.

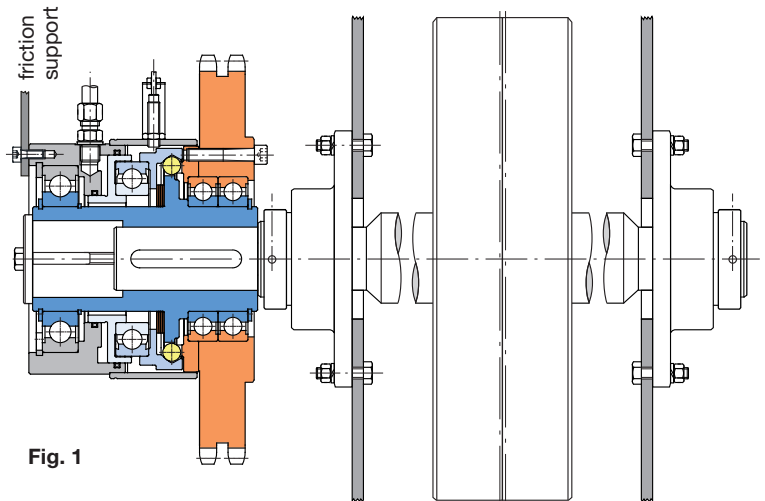

Fig. 1

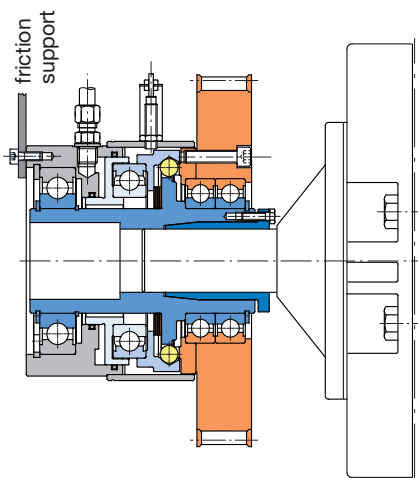

Fig. 2

### EAS<sup>®</sup>-Sp clutch mounted onto shaft end

The clutch is axially secured via a cone bushing and allows a backlash-free torque connection from shaft to hub. The friction support stops the stator element from rotating.

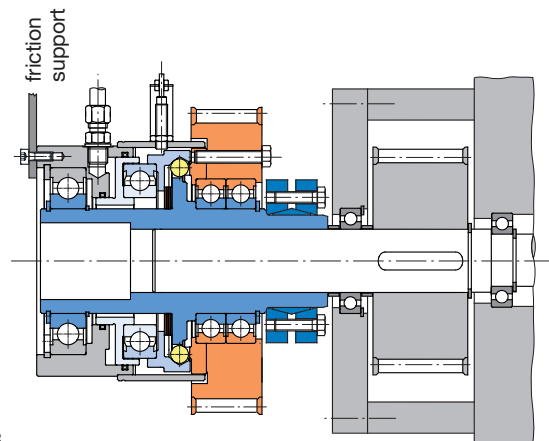

Fig. 3

### EAS<sup>®</sup>-Sp clutch used in a conveyor system

The clutch is axially secured via a shrink disk and allows a backlash-free torque connection from shaft to hub. The friction support stops the stator element from rotating.

## The electromagnetically switchable and controllable control clutch EAS<sup>®</sup>-Sm/Zr

- Combined electromagnetic torque limiting clutch and electrically switchable clutch
- Controllable and adjustable
- Continuous torque adjustment possible during operation
- Synchronous switch-on and switch-off functions of drives in a low speed range (0 – 100 rpm)
- On application of several clutches, individual operation and control of different drives and shafts within one system are possible.
- Optimised drive control by means of the EAS<sup>®</sup>-Sm/Zr control units
- Also available as simple measuring clutch for checking the torques in drive lines

### EAS<sup>®</sup>-Sm/Zr control unit

- Continuous adjustment of the coil current and, therefore, of the limit torque, even during operation
- Overexcitation for shortening the switching time or to achieve higher torques for a short time, e.g. to generate higher flywheel masses with higher speeds.
- Control of the synchronous switch-on and switch-off functions
- Temperature monitoring

### Torque adjustment

The limiting torque is adjusted continuously via the coil current. By doing so the armature disk is attracted magnetically. Armature disk and hub are connected positively.

A uniform and exact torque is maintained due to the *mayr*<sup>®</sup>-EAS<sup>®</sup>-Sm/Zr control unit with constant current control.

Fluctuations in the supply voltage or changes in coil temperature do not influence the torque (within the operating temperature).

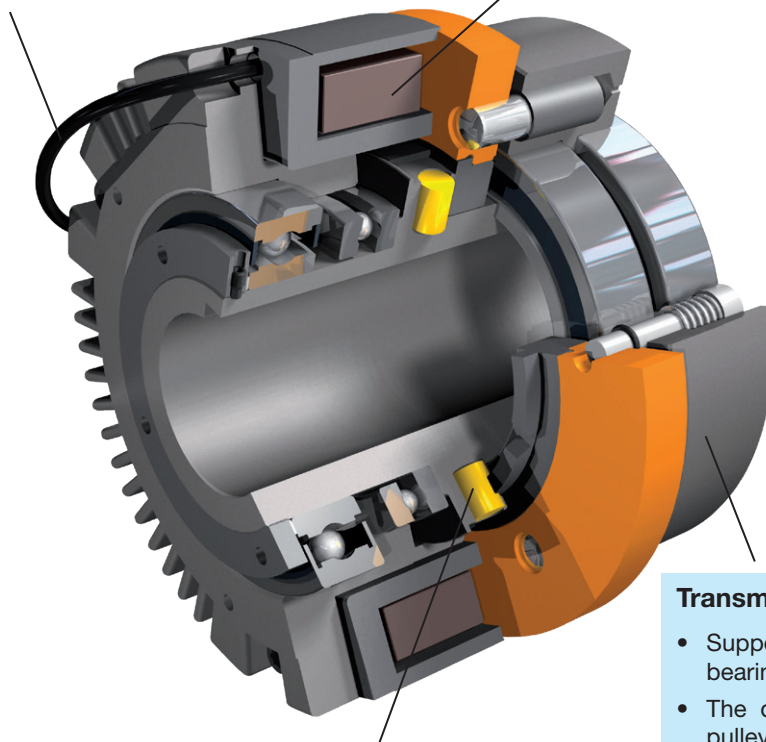

### Torque transmission and limitation

- Adjustable torques are transmitted from the hub to the armature disk and further to the transmitting flange via the *mayr*<sup>®</sup>- precision rollers.
- When the limit torque is exceeded, the pre-set magnetic force is exceeded. The armature disk disengages. The *mayr*<sup>®</sup>-limit switch is then actuated. Input and output are disconnected.

### Transmitting flange

- Supported radially by two deep groove ball bearings
- The drive elements e.g. toothed wheels, pulleys, can easily and precisely be attached.
- Precise axial run-out and shaft run-out



The screw quality and the tightening torque for the fixing screws of the drive element are to be selected so that the set limit torque can be safely transmitted using frictional locking.

## The cyclic, switchable and controllable torque limiting clutch EAS<sup>®</sup>-Sm

- Engagement is guaranteed only at one specific point due to the phased *mayr*<sup>®</sup>-synchronous geometry of the *mayr*<sup>®</sup>-precision rollers and roller detents.
- The EAS<sup>®</sup>-Sm/Zr control unit takes over the clutch control, regulation and monitoring functions at 96 VDC coil nominal voltage.

Versatile adaptation of cycles and processes for a complete system or single system areas are possible.

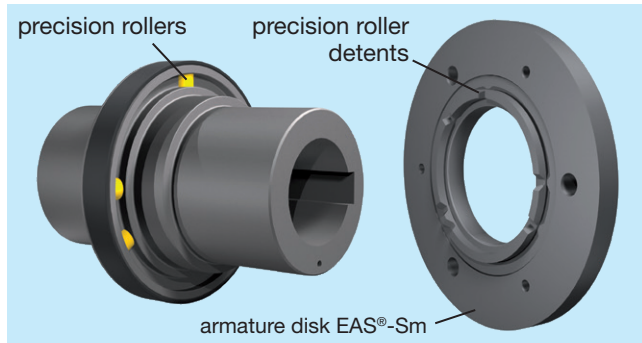

### Functional principle of the EAS<sup>®</sup>-Sm electromagnetic clutch

The EAS<sup>®</sup>-Sm disengages when the pre-set limit torque is reached.

- After a defined cycle is left out and after removal of the overload, the clutch re-engages after 360° at the same point as it disengaged.
- The standard cycle corresponds to 360°. Other cycles, for example 180° are also available.

## The instantly operational, switchable and controllable EAS<sup>®</sup>-Zr control clutch

- Uniform and constant torque transmission due to precision manufacture of the roller detents.
- Prompt readiness for operation of the machine and system after removal of the overload is guaranteed by using the EAS<sup>®</sup>-Zr.
- Switch-on/off with the EAS<sup>®</sup>-Sm/Zr control unit.
- Applications in all types of automated machines.
- Adaptable to constantly changing overloads and cycle speeds.

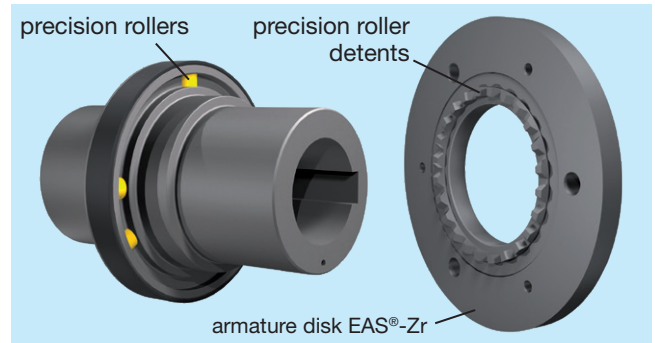

### Functional principle of the EAS<sup>®</sup>-Zr electromagnetic clutch

- The EAS<sup>®</sup>-Zr disengages when the pre-set limit torque is reached. After removal of the overload, re-engagement is made at the next convenient roller detent.
- The *mayr*<sup>®</sup> limit switch is responsible for:
  - immediate drive switch-off
  - or further control functions

### Energised magnetic coil

- As standard with 24V / 96V direct voltage
- Armature disk attracted by the magnetic force
- The level of the magnetic force is determined by the air gap and coil current.
- The air gap is set optimally manufacturer-side.
- The coil current is continuously adjustable, even during operation.

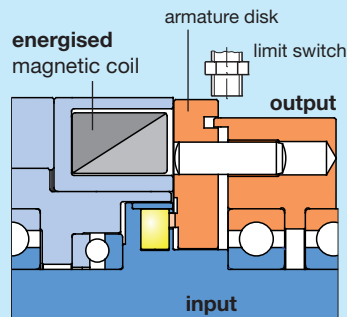

### De-energised magnetic coil

- Input and output are disconnected.

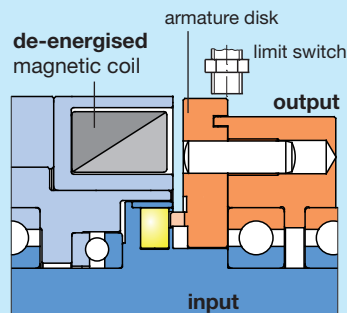

### Application of the EAS<sup>®</sup>-Sm/Zr torque limiting clutches

- in all kinds of automated machines
- with constantly changing overloads
- with changing cycles and speeds
- in packaging machinery
- in filling machinery
- in printing machinery
- in cleaning machinery
- in materials handling equipment

### The EAS<sup>®</sup>-Sm/Zr control clutches in equipment and systems, which are used for

- cycling
- positioning
- controlling
- checking
- A control-technical standard for
  - ... sequences
  - ... processes
  - ... adaptations

**EAS<sup>®</sup>-Sm/Zr  
Standard**

**Type 400.03\_.\_  
Sizes 0 to 4**

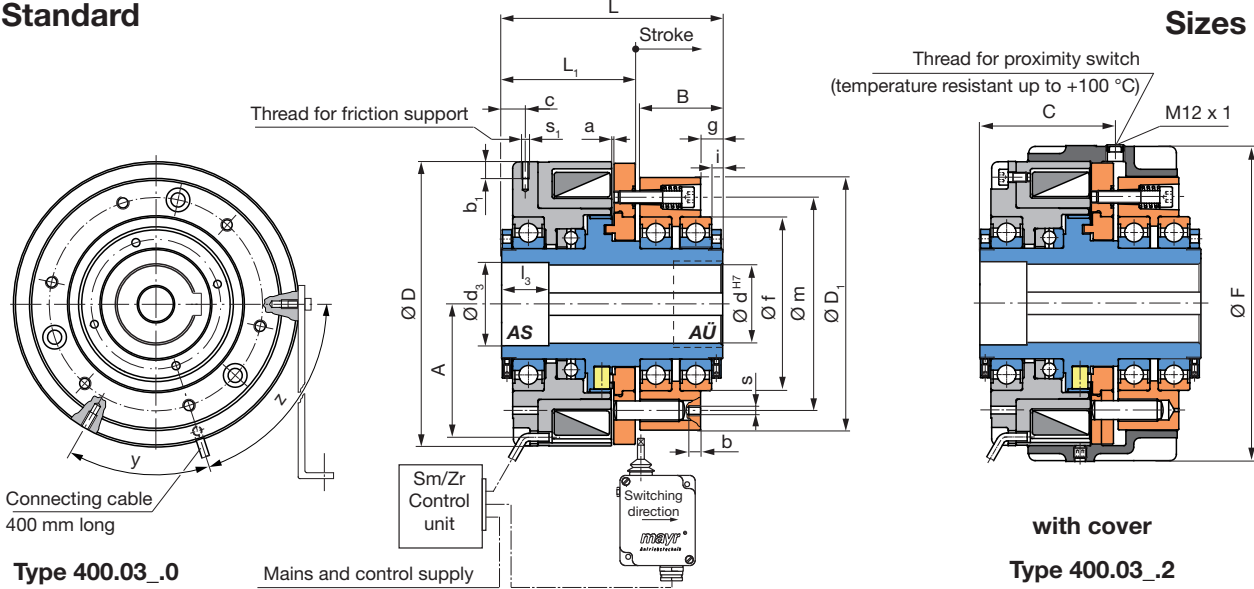

Type 400.03\_0

Mains and control supply

with cover  
Type 400.03\_2

Technical Data			Size				
			0	1	2	3	4
Limit torque for overload	$M_G$	[Nm]	6 – 25	12 – 50	25 – 100	50 – 200	100 – 375
Max. speed <sup>1)</sup>	$n_{max}$	[rpm]	4000	3000	2500	2000	2000
Electrical power	$P_{20}$	[W]	36	46	56	73	105
Mass moment of inertia with $d_{max}$	Hub side	$I$ [10 <sup>-3</sup> kgm <sup>2</sup> ]	0.35	1.3	3.05	5.93	11.77
	Flange side	$I$ [10 <sup>-3</sup> kgm <sup>2</sup> ]	1.99	4.31	8.35	1.603	3.624
Weight <sup>2)</sup> with $d_{max}$	$m$	[kg]	4.0	6.0	9.0	13.7	20.2
Stroke		[mm]	1.8	2.3	2.5	3.0	3.5

Dimensions [mm]	Size				
	0	1	2	3	4
A	53	63	72.5	84.5	99
$a_{min}$ <sup>3)</sup>	0.25	0.25	0.3	0.3	0.35
B	37.5	41	47.5	52.5	58
$b^{6)}$	13.5	13.5	16	21	26
$b_1$	8	10	10	10	16
C	62	68	76.5	86	95
c	11.5	11.5	14	15	17
D	115	135	155	180	210
$D_1$	100	120	135	160	185
F	130	150	170	200	230

Dimensions [mm]	Size				
	0	1	2	3	4
$f_{h6}$ <sup>5)</sup>	62	80	95	110	125
g	12	12	14	14	17
i	6	6	7	7	9
L	100	110	125	140	155
$L_1$	60.3	66.3	74.8	84.3	93.3
m	80	100	115	135	155
$s^{6)}$	6 x M5	6 x M5	6 x M6	6 x M8	6 x M10
$s_1$	2 x M5	2 x M5	2 x M5	2 x M5	2 x M6
y	48°	48°	48°	48°	48°
z	72°	72°	72°	72°	72°

- 1) The speed for re-engagement or for switching operation depends on the mass to be accelerated and the load torque (see "Technical Explanations" page 14).
- 2) Without cover
- 3) Nominal dimension adjusted manufacturer-side
- 4) Smaller bores on request
- 5) Tolerance user-side H7
- 6) Min. screw-in depth 2.5 x s
- 7) The position of the keyway to the mounting bore "s" in the pressure flange is not defined. Defined position available on request.

Bores [mm]	Size				
	0	1	2	3	4
d pilot bore <sup>4)</sup>	9	14	18	22	24
$d_{max}$ DIN 6885/1	22	35	42	50	60

We reserve the right to make dimensional and constructional alterations.

Counterbores [mm]	Size				
	0	1	2	3	4
Counterbore	$d_3$	20 23 26 37 37 37 47	-	37 47 51 37 47 67	-
	$l_3$	65 45 65 45 25 60 40	-	75 55 25 90 70 40	-
on bore d	over	9 14 14 19 28 19 28 38	22 28 38	24 28 38 55	
	up to	14 22 19 28 35 28 38 42	28 38 50	28 38 55 60	

**Order Number**

EAS <sup>®</sup> -Sm clutch	<b>6</b>	Counterbore coil carrier-side	<b>AS</b>
EAS <sup>®</sup> -Zr clutch	<b>8</b>	Counterbore transmission flange-side	<b>AÜ</b>
_ / 4 0 0 . 0 3 _ . _ / _ / _ / _ / _ / _			
Sizes 0 to 4	Standard with cover 0	Voltage [VDC] 24 96	Hub bore $\varnothing d^{H7}$
	with limit switch 2		Keyway <sup>7)</sup> acc. DIN 6885/1
			with limit switch see pages 22 – 23

Example: Order Number 1 / 400.036.0 / 96 / 30 / 6885/1 / AS / with limit switch 055.000.5

### EAS®-Sm/Zr Torsionally rigid

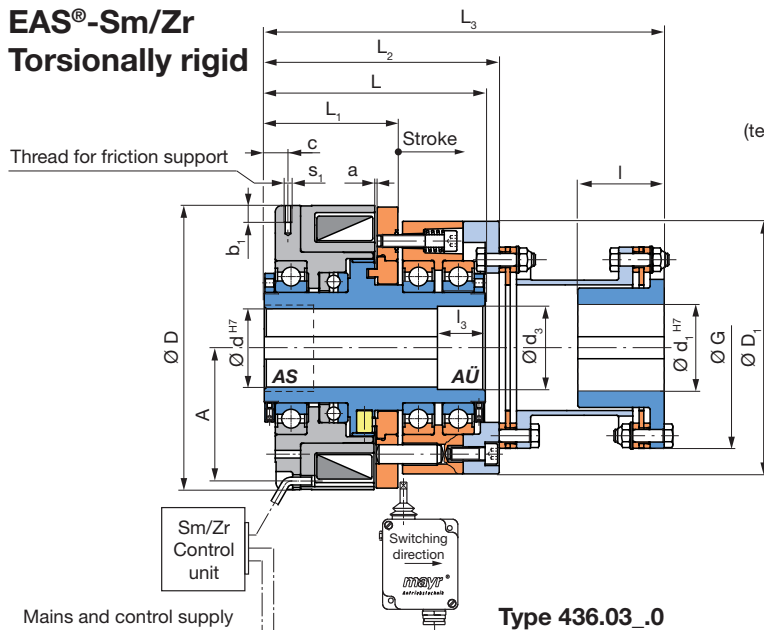

### Type 436.03 \_. Sizes 0 to 4

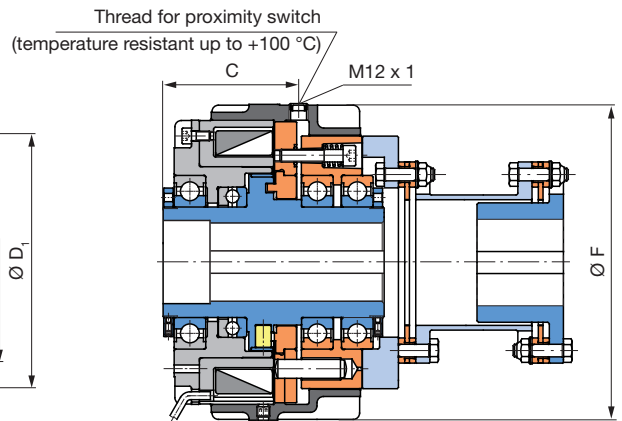

with cover

Type 436.03 \_0

Type 436.03 \_2

Technical Data			Size				
			0	1	2	3	4
Limit torque for overload	$M_g$	[Nm]	6 – 25	12 – 50	25 – 100	50 – 200	100 – 375
Nominal torques, torsionally rigid coupling			30	50	100	200	400
Max. speed <sup>1)</sup>	$n_{max}$	[rpm]	4000	3000	2500	2000	2000
Electrical power	$P_{20}$	[W]	36	46	56	73	105
Mass moment of inertia with $d_{max}$	Hub side	$I$	0.35	1.3	3.05	5.93	11.77
	Flexible side	$I$	3.7	7.8	14.1	28.96	64.42
Weight <sup>2)</sup> with $d_{max}$	$m$	[kg]	5.5	8.0	11.5	18.2	27.0
Stroke		[mm]	1.8	2.3	2.5	3.0	3.5

Dimensions [mm]	Size				
	0	1	2	3	4
A	53	63	72.5	84.5	99
$a_{min}$ <sup>3)</sup>	0.25	0.25	0.3	0.3	0.35
$b_1$	8	10	10	10	16
C	62	68	76.5	86	95
c	11.5	11.5	14	15	17
D	115	135	155	180	210
$D_1$	100	120	135	160	185
F	130	150	170	200	230
G	80	92	102	128	145
L	100	110	125	140	155
$L_1$	60.3	66.3	74.8	84.3	93.3
$L_2$	106	116	130	149	162
$L_3$	173	193	217	254	287
l	35	40	45	55	65
$s_1$	2 x M5 2 x M5 2 x M5 2 x M5 2 x M6				

Bores [mm]	Size	Size				
		0	1	2	3	4
d pilot bore <sup>4)</sup>		9	14	18	22	24
$d_{max}$ DIN 6885/1		22	35	42	50	60
$d_{1min}$ DIN 6885/1		8	8	12	15	20
$d_1$ DIN 6885/1		23	35	42	55	65
$d_{1max}$ DIN 6885/3		28	38	45	-	-

Counterbores [mm]	Size	Size														
		0		1		2		3		4						
Counterbore	$d_3$	20	23	26	37	37	37	47	-	37	47	51	37	47	67	-
	$l_3$	65	45	65	45	25	60	40	-	75	55	25	90	70	40	-
on bore d	over	9	14	14	19	28	19	28	38	22	28	38	24	28	38	55
	up to	14	22	19	28	35	28	38	42	28	38	50	28	38	55	60

- 1) The speed for re-engagement or for switching operation depends on the mass to be accelerated and the load torque (see "Technical Explanations" page 14).
  - 2) Without cover
  - 3) Nominal dimension adjusted at the factory
  - 4) Smaller bores on request
- We reserve the right to make dimensional and constructional alterations.

### Order Number

EAS®-Sm clutch	6	Counterbore coil carrier-side						AS
EAS®-Zr clutch	8	Counterbore transmission flange-side						AÜ
<p>___ / 4 3 6 . 0 3 ___ . ___ / ___ / ___ / ___ / ___ / ___ / ___ / ___</p>								
Sizes 0 to 4	Standard with cover 0	2	Voltage [VDC] 24 96	Hub bore Ø d <sup>H7</sup>	Keyway acc. DIN 6885/1	Hub bore Ø d <sup>H7</sup>	Keyway-acc. DIN 6885/1 6885/3	with limit switch see pages 22 – 23

Example: Order Number 1 / 436.036.0 / 96 / 30 / 6885/1 / 35 / 6885/1 / AÜ / with limit switch 055.000.5

## Technical explanations

### Operating speeds

The speeds mentioned on pages 12 and 13 are operating speeds which refer to the clutch in engaged condition.

The re-engagement speed of the EAS<sup>®</sup>-Sm/Zr clutches depends on the corresponding clutch size or on the mass moments of inertia of the flanged drive elements. Re-engagement or connection of the clutch under load conditions should not take place.

**Please contact our application engineers regarding your special application.**

### Torque adjustment

Adjusting and altering the torque can be accomplished by altering the coil voltage.

The torque capacity is proportional to the coil current, independent of the coil temperature. A consistent coil current should therefore be maintained.

Using the EAS<sup>®</sup>-Sm/Zr control unit enables the torque to be simply and rapidly adjusted and controlled. The consistent current regulator on the control unit guarantees exact and consistent torque. Coil fluctuations do not affect the set torque (within the operational temperature).

### Electrical connection

The supply voltage for the magnetic coil depends on the design, 24 VDC or 96 VDC being standard.

For monitoring the coil temperature there is a PTC resistor in the coil (please see Installation and Operational Instructions B.4.9.GB).

The clutch together with the limit switch can be connected via the Sm/Zr control unit. You can find Technical Data and Explanations on the control unit from page 19 onward.

### General installation guidelines

The EAS<sup>®</sup>-Sm/Zr is a permanently energised switchable and controllable torque limiting clutch. In connection with this, it should be mentioned that magnetic fields can encroach on the clutch supports or drive elements, and affect their function.

After actuating the mechanical limit switch, the clutch output should stop immediately, as otherwise the lever mounted on the limit switch will be worn down due to grinding of the armature disk, meaning that the function of the clutch or limit switch can no longer be guaranteed.

To avoid clutch failures in max. torque ranges caused by thermal overload, the ambient temperature for the clutch should not exceed 40 °C.

The permitted ambient temperature increases during operation with low torque.

### Securing the clutch onto the shaft

EAS<sup>®</sup>-Sm and EAS<sup>®</sup>-Zr clutches are supplied with finish bores and keyways according to DIN 6885.

The clutch is mounted onto the shaft using a suitable device and axially secured using a press cover, set collars or locking rings.

### Attaching the friction support

The magnetic element of the clutch must not rotate freely. A support is required to absorb the low friction torque caused by the roller bearing on the static magnetic part (Figs. 7 and 8, page 15).

The friction support must not transmit any appreciable forces (distortions) onto the clutch.

## Limit Switch Installation

### Contactless sensing with limit switch Type 055.009.6 – magnetic field-resistant –

#### Installation into EAS<sup>®</sup>-Sm/Zr clutch with cover

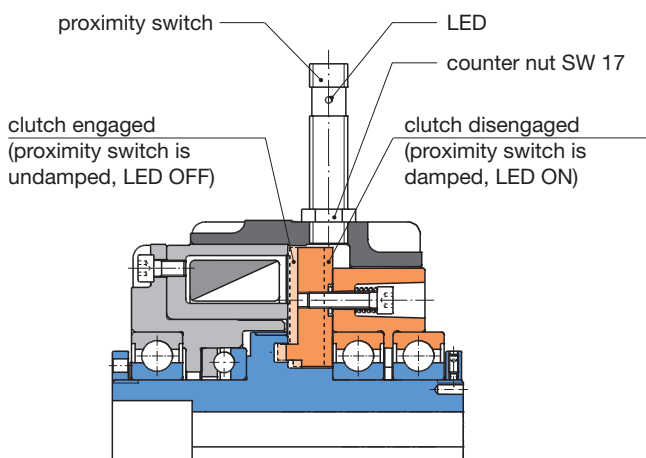

Fig. 4

Screw in proximity switch (without connection cable) with disengaged clutch up to contact, and then turn it back again by approx. 1 1/4 revolutions.

Lock it with a counter nut against loosening.

#### Mounting onto the EAS<sup>®</sup>-Sm/Zr clutch without cover

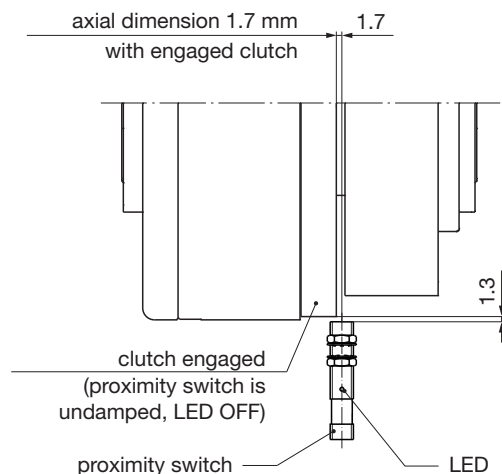

Fig. 5



Incorrect limit switch installation causes faulty operation, i.e. no monitoring of the overload.

## Mechanical sensing with limit switch Type 055.000.5 – light metal housing –

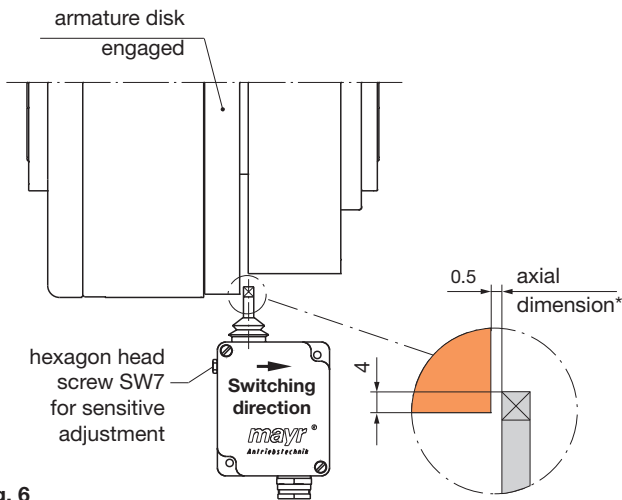

Fig. 6



Incorrect limit switch installation causes faulty operation, i.e. no monitoring of the overload. If the clutch is disengaged and the drive is running, the switch lever is worn down due to grinding. In this case, a contactless switch should be used (see “Mounting onto the EAS<sup>®</sup>-Sm/Zr clutch without cover”, page 14).

\* The axial dimension 0.5 mm is adjusted with an engaged clutch and can be sensitively adjusted using a hexagon head screw SW7.

## Installation Examples

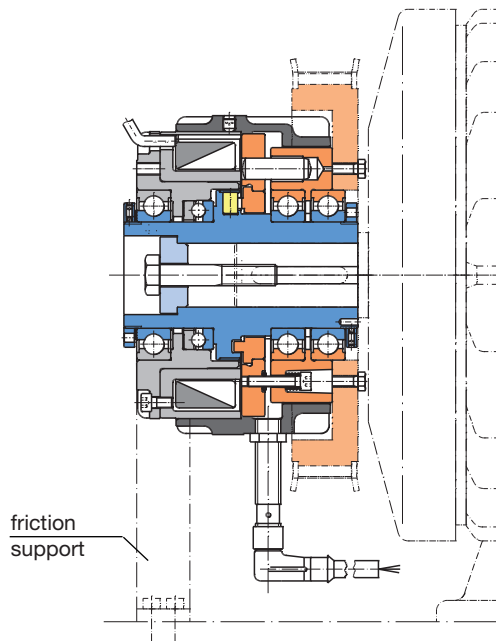

Fig. 7

### EAS<sup>®</sup>-Sm clutch with cover

The clutch is axially secured to the shaft via a press cover and a screw, screwed into the threaded centre hole in the shaft.

The cover prevents contamination of the air gaps between the magnetic part and the armature disk and the armature disk and the transmission flange.

Free axial movement of the armature disk must be ensured.

The cover serves as a mounting point for the contactless proximity switch (the proximity switch is set in the factory). The friction support absorbs the frictional torque of the roller bearings between the hub and the magnetic part and stops the magnetic part from rotating.

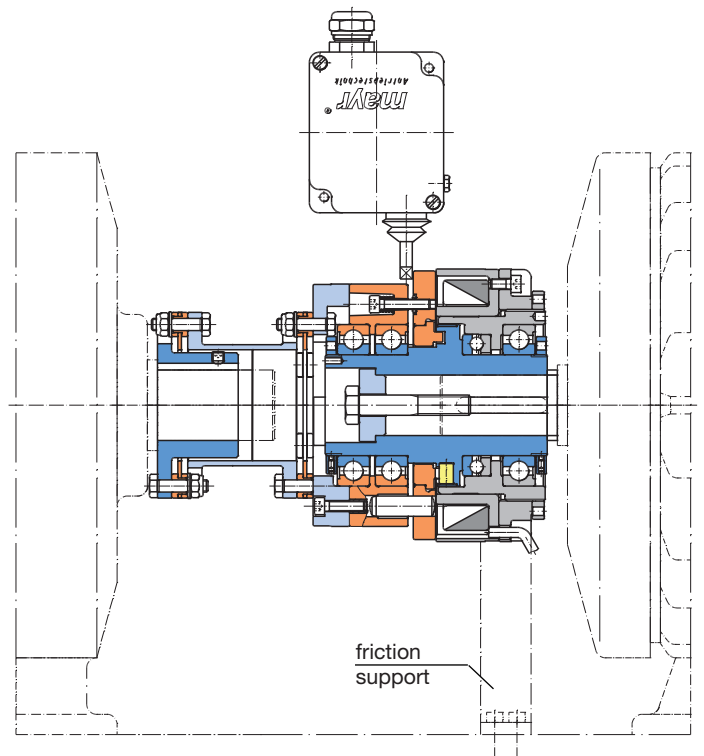

Fig. 8

### EAS<sup>®</sup>-Sm clutch combined with a torsionally rigid, flexible all-steel coupling

The EAS<sup>®</sup>-Sm clutch is axially secured onto the motor shaft by a press cover and screw. A set screw secures the torsionally rigid coupling hub onto the gear box shaft. The torsionally rigid, flexible coupling compensates for radial, axial and angular shaft misalignments. When the clutch disengages, the armature disk moves axially and operates the limit switch.

The friction support stops the magnetic part from rotating.

## EAS<sup>®</sup>-Sp control unit Type 009.000.2

### Application

This unit is used to monitor, control and to signal overload on pneumatically controllable overload clutches with switching functions.

### Function

The EAS<sup>®</sup>-Sp control unit monitors the switching condition of the clutch and emits a signal when the set torque is exceeded. It controls pneumatic valves which are used to lock or to open the compressed air supply or to switch from engagement pressure 2 to torque pressure 1.

**Switching valve** opens or closes the compressed air supply to the clutch; connections V2a / V2b

**Pressure valve** switches over between engagement pressure 2 and torque pressure 1; connections V1a / V1b

Both connections are resistant against short-circuiting.



### Electrical connection

24 VDC/Gnd +24 VDC input voltage  
(special design: 2 change-over contacts)



Installed protection against incorrect polarity!  
To set up the voltage supply in the EAS<sup>®</sup>-Sp control unit, the correct connection voltage polarity is necessary.

- ON Start button / (+) connection for PLC control
- OFF Stop button / (-) connection for PLC control
- Gnd1 (+) Connection for PLC control
- End Limit switch signal
- Gnd (-) Connection for limit switch
- 12 V (+) Output voltage for ON/OFF contacts and limit switch
- V1a / V1b Pressure valve 24 VDC
- V2a / V2b Switching valve 24 VDC
- 14 - 11 - 12 **Overload signalling relay**, floating change-over contacts, max. contact load 250 VAC / 10 A



Do not apply any external voltage to the 12 V terminal.

### Dimensions (mm)

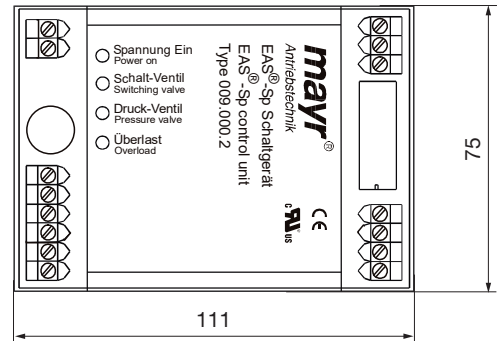
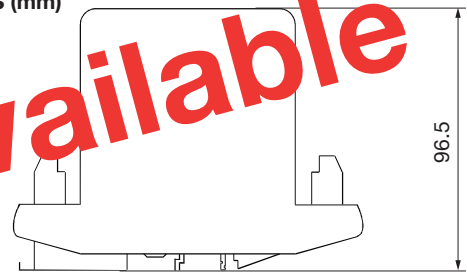

No longer available

### Functional sequence

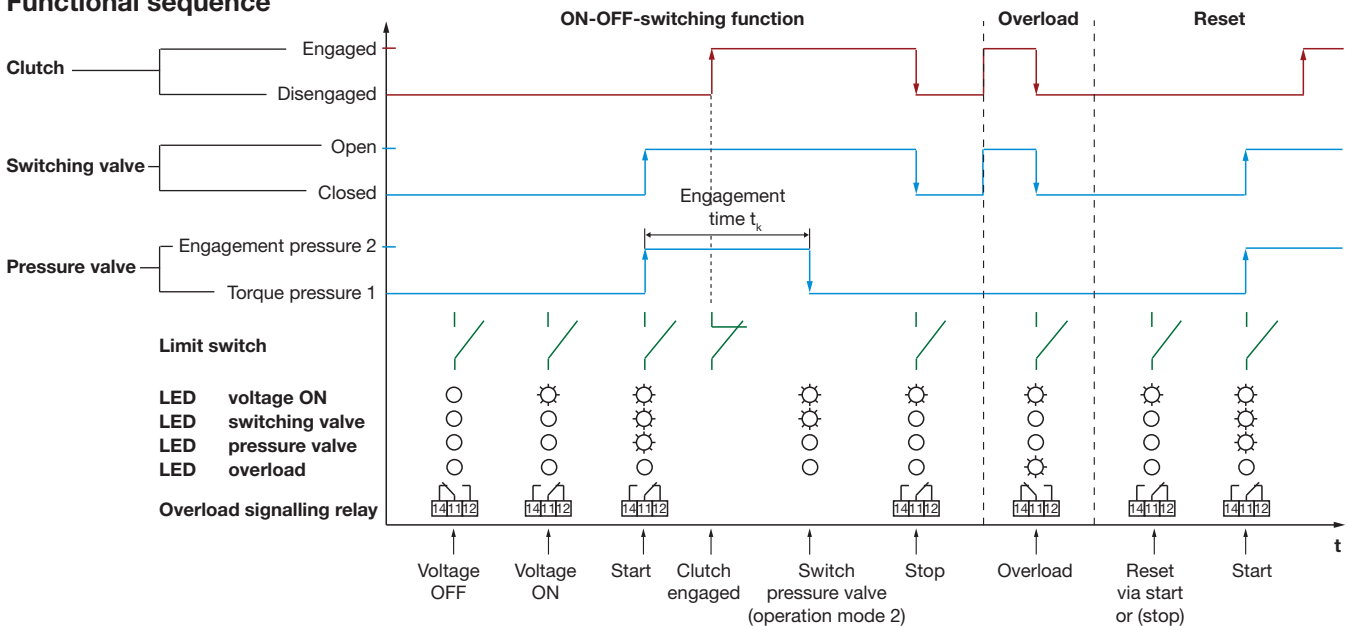



## Installation

The unit is installed using a snap fastener attached to the housing, which can be attached to all DIN EN mounting rails.



Power connections are to be laid interference-free! The control wires (ON – OFF – Gnd1 – End – Gnd2 –12 V) are to be laid separately and at a sufficient distance from the high voltage current or pulsating wires (PE / L1 / N).

## Adjustments

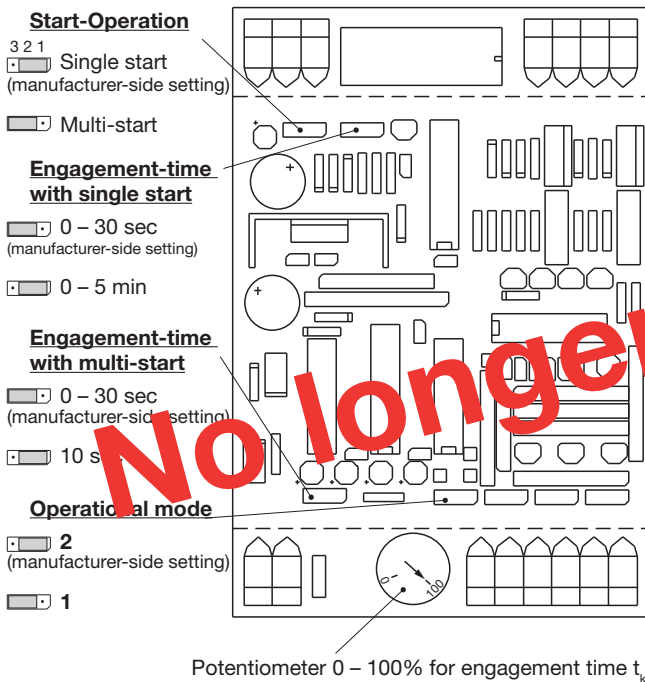

To avoid disorders or malfunctions, the operational modes are to be observed before making adjustments.

## Engagement time $t_k$

Adjustments of the engagement time  $t_k$  are to be carried out using the external potentiometer 0 – 100 %.

**Adjustment of the engagement times for the following operational conditions:**

### 1. Single start (manufacturer-side setting)

- Coding bridge: “Engagement time for single start” (Manufacturer-side setting) 0 – 30 s (for speeds > 2 rpm)
- Changing the coding: 0 – 5 min. (for speeds < 2 rpm)

### 2. Multi-start (by changing the settings)

- a. Single start operation (for first impulse-start)**
  - Coding bridge: “Engagement time for single start” (Manufacturer-side setting) 0 – 30 s
  - Changing the coding: 0 – 5 min.
- b. Multi-start operation (second and additional impulses)**
  - (Manufacturer-side setting) 0 – 30 s
  - Changing the coding: 10 s

## Operational mode 1 (Please observe the settings)

Switch over from engagement pressure 2 to torque pressure 1, if the clutch is engaged and the limit switch is actuated. The remaining engagement time is set to zero.

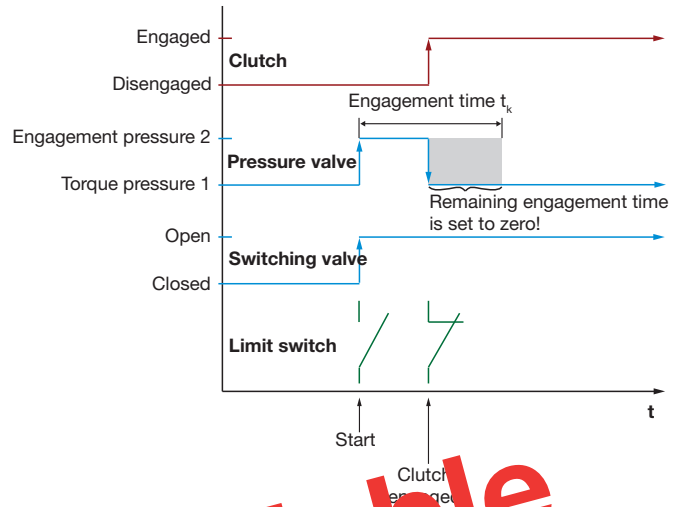

## Operational mode 2 (Manufacturer-side setting)

Switch over from engagement pressure 2 to torque pressure 1 when the engagement time  $t_k$  has passed and the clutch remains engaged.



Clutch-ratchetting during the engagement time  $t_k$  causes disconnection of the clutch and emission of an overload signal.

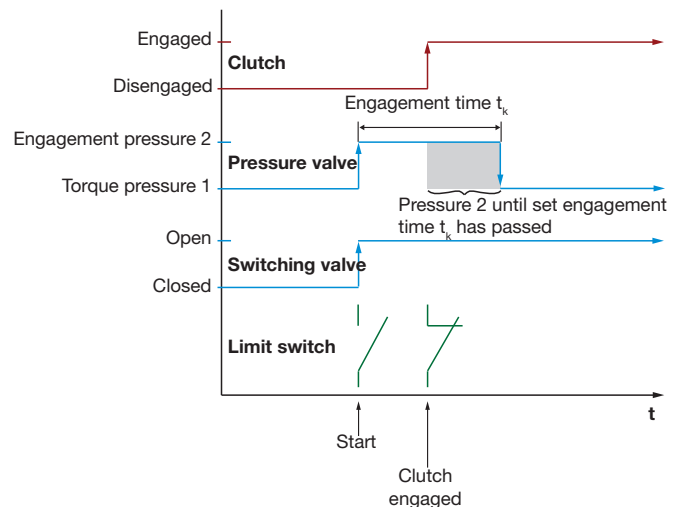

## Multi-start (Please observe the settings)

The multi-start allows repetition of the engagement pressure 2 switch-on during functional operation.

Application possibilities in operational modes 1 or 2 and only with the 2-contact functional control.

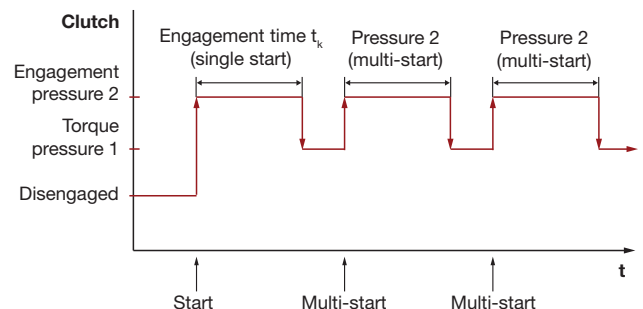

### Connection example

#### Control elements / Control functions

Application	Function
	<b>2 contacts</b>  <b>Start:</b> close ON contact <b>Stop:</b> open OFF contact
	<b>PLC control</b>  <b>Start:</b> + 24 VDC <b>Stop:</b> 0 VDC  PLC control 10 – 30 VDC
	<b>1 contact</b>  <b>Start:</b> close contact <b>Stop:</b> open contact

### Connection example

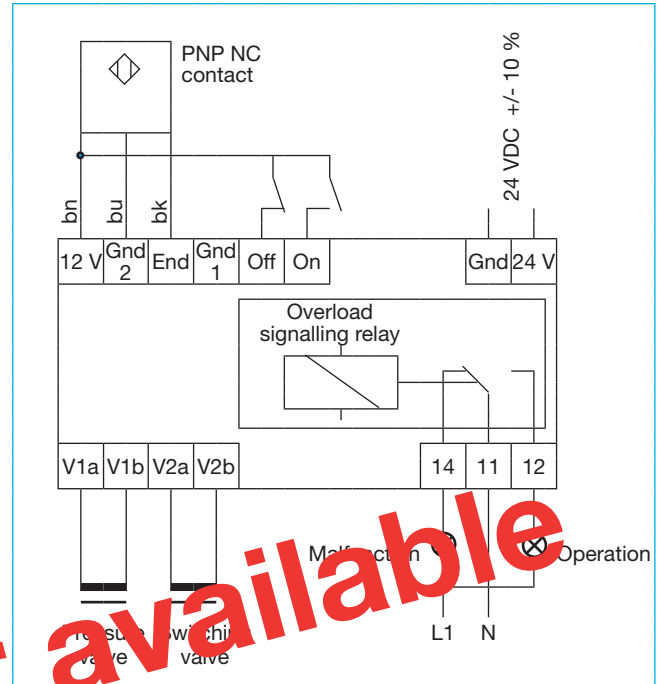

#### Limit switch (monitoring)

Application	Function
	<b>1 contact</b>  <b>Clutch engaged:</b> Contact closed <b>Clutch disengaged:</b> Contact open
	<b>PLC control</b>  <b>Engaged:</b> + 24 VDC <b>Disengaged:</b> 0 VDC  PLC control 10 – 30 VDC
	<b>PNP NC contact</b>  <b>Clutch engaged:</b> Sensor undamped <b>Clutch disengaged:</b> Sensor damped  PNP NC contact: 3-wire sensor, 10 – 30 VDC

No longer available

#### Technical data

Input voltage	+24 VDC, +/-10 %
Connection pressure valve	+24 VDC / 0.5 A, resistant against short-circuits
Connection switching valve	+24 VDC / 0.5 A, resistant against short-circuits
Current consumption	max. 1 A / 100 % duty cycle
No-load supply power	< 1 W
Protection	IP 20
Operating temperature	0 up to +50 °C
Storage temperature	-20 up to +70 °C
Max. clampable conductor cross section	0.14 - 2.5 mm <sup>2</sup> / AWG 26-14
Weight	210 g
Overload signalling relay	floating change-over contacts, max. contact load 250 VAC / 10 A
Conformity markings	UL-Standard UL 508 CSA-Standard C22.2 No. 14-M91
Short-circuit-resistant coil connections	If a short-circuit occurs, the electronic monitoring registers this and switches off the affected coil voltage between the coil connections V1a and V1b or V2a and V2b.



No overload status signal will be emitted if the limit switch is not installed according to the regulations.



The customer is responsible for providing the input voltage-side protection fuse.

#### Order Number

0 0 9 . 0 0 0 . 2

## EAS<sup>®</sup>-Sm/Zr control unit Type 010.000.2



### Application

This unit is used to switch, control, monitor and to indicate overload for adjustable EAS<sup>®</sup>-Sm synchronous clutches and EAS<sup>®</sup>-Zr overload clutches.

### Function

The EAS<sup>®</sup>-Sm/Zr control unit works according to the principle of cycled switching controllers with a frequency of 18 kHz. It switches, controls and monitors the clutch and emits a signal when the set torque is exceeded.

### Switched with

- floating contacts
- PLC control with 10 – 30 VDC

### Controlled by

- coil current

### Monitored with

- floating contacts
- magnetic field-resistant proximity switches up to +100 °C

### Temperature monitors

- coil-clutch > +130 °C
- control unit > +80 °C

### Electrical connections

PE, L1, N	connection input voltage
Ku1 / Ku2	coil connection for clutch
14 – 11 – 12	contact signalling relay 1 (overload)
24 – 21 – 22	contact signalling relay 2 (excessive temperature)
On	connection "Start" button
Off	connection "Stop" button
Gnd1	(-) connection with PLC control
End	limit switch signal
Gnd2	(-) connection for limit switch
12V	(+) connection for ON-button, OFF-button and limit switch
Gnd3	(-) connection with analogue torque adjustment
M	(+) connection with analogue torque adjustment
P1,P2	connection for coil thermistor (or bridge)

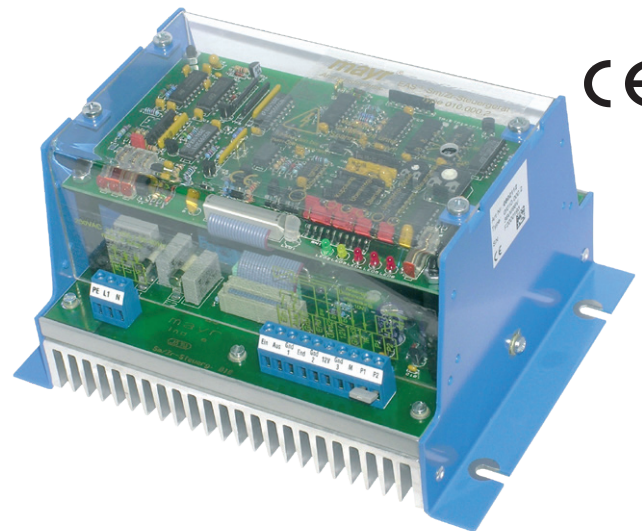

### Dimensions (mm)

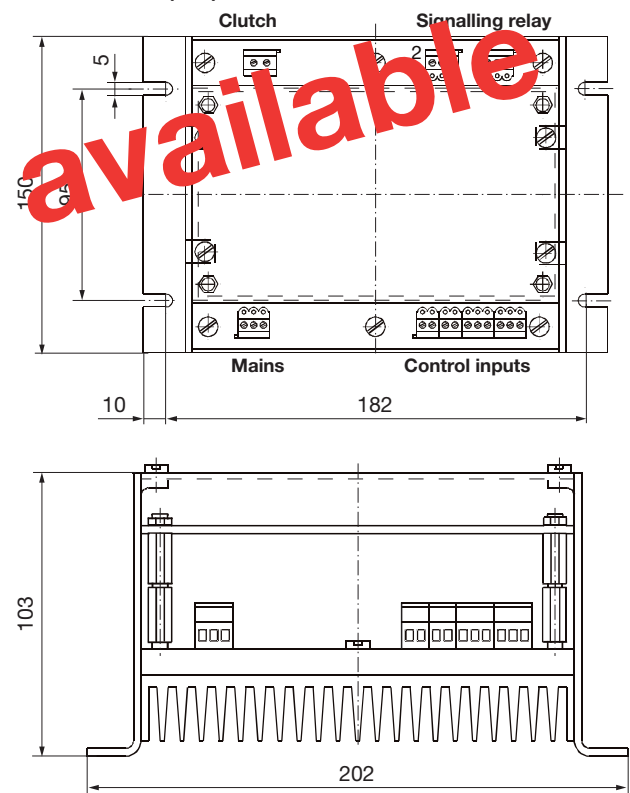

### Functional sequence

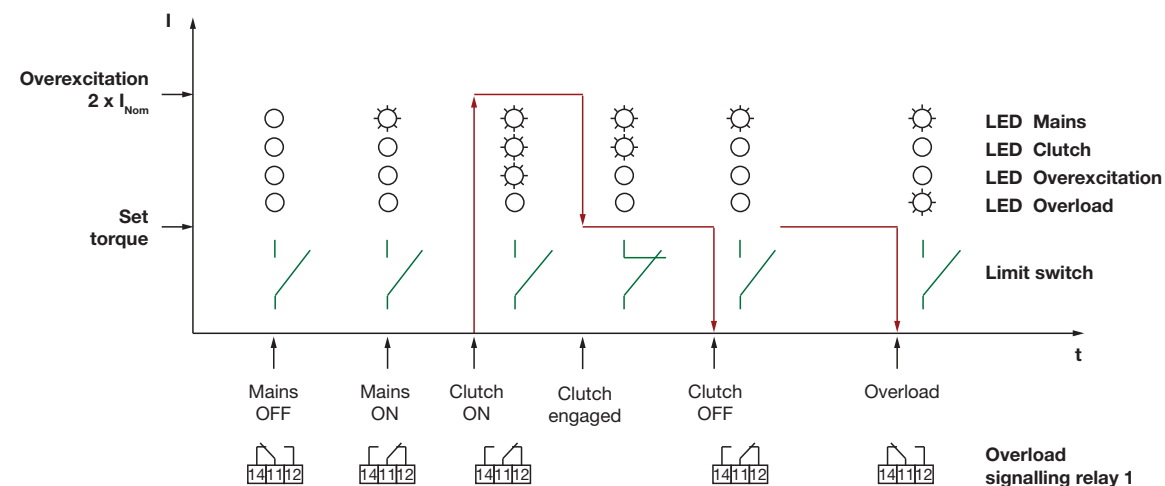

## Installation / Connection examples



Do not apply external voltage to the 12 Volt terminal.  
Ensure **well-conducting connections** between the control unit housing and the metallic screw-on surface.  
Use toothed lock washers or spring washers under the fixing screws.  
Power connections are to be laid interference-free!  
The control wires (ON / OFF / Gnd1 / End / Gnd2 / 12 V / Gnd3 / M / P1 / P2) are to be laid separately and at a sufficient distance from the high-voltage current or pulsating wires (PE / L1 / N / Ku1 / Ku2).  
Installation should correspond to the **EMC directives!**

### Start/Stop PLC control (PLC control 10 – 30 Volt)

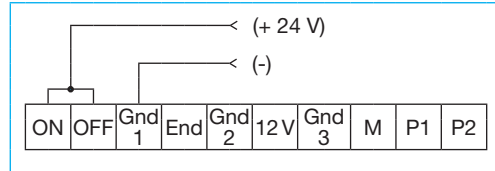
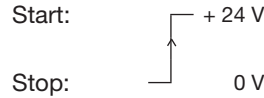

### Analogue torque adjustment (observe coding!)

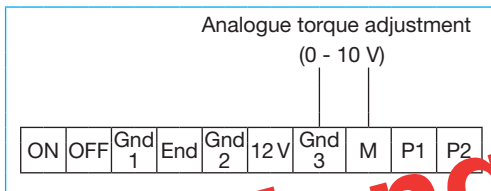

### Limit switch (1 contact)

Clutch engaged: contact closed  
Clutch disengaged: contact open

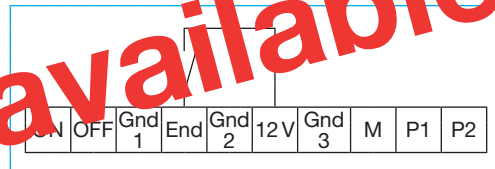

### Connection example for thermistor or bridge

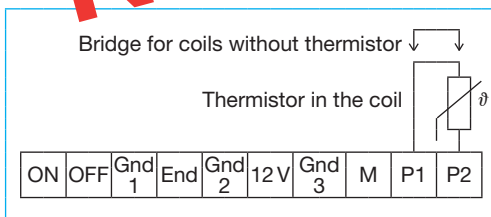

### Limit switch PLC control (PLC control 10 – 30 Volt)

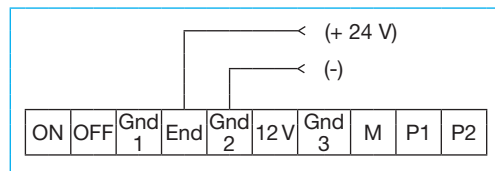
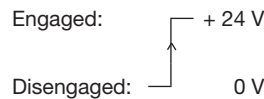

### Start/Stop (2 contacts)

Start: close ON contact  
Stop: open OFF contact

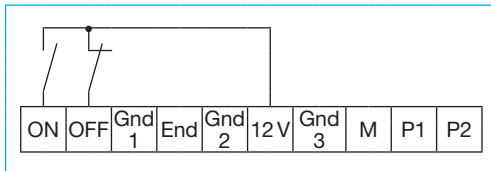

### Limit switch PNP NC contact

PNP NC contact: 3-wire, magn. field-resistant proximity switch, 10 – 30 VDC, operating temperature 100 °C.



No overload status signal will be emitted if the limit switch is not installed according to the regulations.

Clutch engaged: sensor undamped  
Clutch disengaged: sensor damped

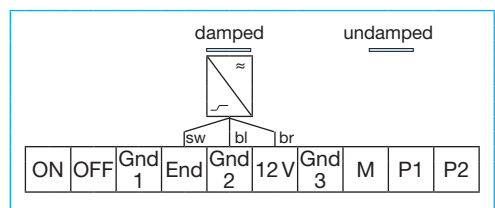

### Start/Stop (1 contact)

Start: close ON contact  
Stop: open OFF contact

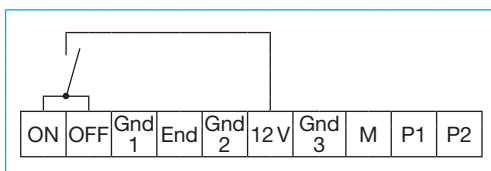

## Settings

### Engagement time $t_k$ (= overexcitation time)

The engagement time  $t_k$  is set to the max. time of 5 s (manufacturer-side setting). The engagement time is determined by:

- Mode 1** The engagement time is stopped, i.e. switched from overexcitation to torque current when the clutch engages, as the limit switch is actuated.
- Mode 2** When the set time has passed (independent of the clutch switch condition), overexcitation switches to torque current.

## Technical data

Input voltage	230 VAC, $\pm 10\%$ , 50 - 60 Hz
Current consumption	max. 4 A / 100 % ED
No-load power	< 4 Watt
Coil <sub>Nom</sub> -voltage	96 VDC
Coil <sub>Nom</sub> -power	max. 256 Watt
Coil <sub>Nom</sub> -current	<b>Manufacturer-side setting</b> according to the mayr® - EAS®-Sm/Zr - clutch size
Coil overexcitation	$2 \times I_{Nom}$ , current limitation is adapted to the respective coil size.
Torque adjustment	25 % up to 0 % of the coil current (current stabilization)
Engagement time $t_k$	5 seconds $\pm 30\%$
Protection	IP 20
Ambient temperature	0 °C up to + 50 °C
Storage temperature	- 20 °C up to + 70 °C
Max. clampable conductor cross section	2.5 mm <sup>2</sup> / AWG 30-12
Weight	1.5 kg / 3.31 lb
Device fuses	
Input-side G-microfuse	F1/F2, (4 A MT, 5 x 20 mm)
Coil-side G-microfuse	F3. The current is adapted to the mayr® - clutch size. Always use the same spare fuse.
Overvoltage category	Two; one for connection to PELV/SELV (control wires), EN 50178 - 04/1998
Overvoltage protection	<b>For installation in overvoltage category III, a suitable overvoltage protection is required between the input voltage and the EAS® Sm/Zr control unit.</b>

## Control unit temperature monitoring

A fitted temperature switch prevents the control unit from overheating.

- Switch-off** The coil voltage is switched off at an operating temperature of > 80 °C.
- New start** Coil<sub>Nom</sub>-current manufacturer-side setting can only take place after the unit temperature has cooled to below +40 °C.
- Reset** Switching the input voltage off and on again

## Clutch coil temperature monitoring

The coil temperature monitoring can only be used with a fitted thermistor. The thermistor should be connected to terminals P1/P2.

- Advance warning at > + 130 °C operating temperature**  
The coil voltage is not yet switched off.
- Switch-off at > + 135 °C operating temperature**  
The coil voltage is switched off.
- New start** can only take place after the coil temperature has cooled to below + 120 °C.
- Reset** is energised by clutch "Start".

## Short-circuit-resistant coil connection

If a short-circuit occurs between the coil connections Ku1 and Ku2, the coil voltage is switched off. Short-circuit monitoring is reset by switching off the input voltage and removing the short-circuit.



### Not protected against earth short-circuits!

Connecting the coil connections Ku1 or Ku against earthed metal components causes earth short-circuits and therefore to unit failures. It may be necessary to equip the system with an **earth leakage circuit breaker (ELCB)**, to protect against injury or damage. However, this does not protect against control unit failure.

## Order Number

— / 0 1 0 . 0 0 0 . 2



Sizes  
0  
to  
5

## Limit switch Type 055.000.5 (Mechanical Operation)



### Application

This device is used to monitor mechanical movements and end positions. It is a controlling sensor for electronic and mechanical sequences. It also registers axial disengaging movements, e.g. on EAS<sup>®</sup>-clutches.

### Function

The pre-tensioned contact is discharged by actuating the switching lever:  
Contacts 11 – 14 (21 – 24) open, contacts 11–12 (21 – 22) close.

### Design

The microswitch is fitted into a light metal housing and is actuated by a switching lever. Actuation is only possible in one direction. The limit switch is fixed using M4 cap screws via two screw-on mounting links attached diagonally.



### Technical data

Contact	1 change-over contact (special design: 2 change-over contacts)
Switching capacity	250 VAC / 15 A (with 2 change-over contacts: 10A) 24 VDC / 6 A 60 VDC / 1.5 A 250 VDC / 0.2 A min. 12 VDC / 10 mA
Contact material	AgCdO 90/10
Switching frequency	max. 200 switching operations/min
Ambient temperature	-10 °C up to +85 °C
Protection	IP54
Weight	275 g
Switching path setting	Using the adjusting screw (SW 7), the zero point can be moved right or left by max. 5 mm.
Switching path	Advance travel: min. 0.15 up to 0.5 mm Overtravel: max. 10 mm, depending on the zero point setting
Special Types	Different switching lever lengths as well as a design with 2 change-over contacts are possible on request.

### Dimensions (mm)

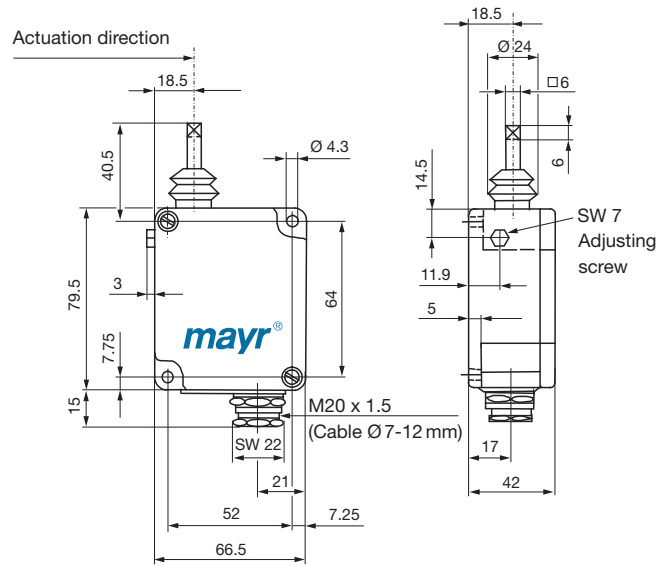

### Electrical connection

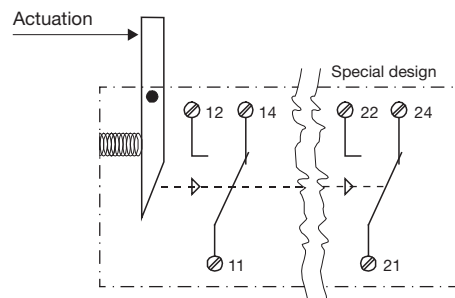

### Order Number

0 5 5 . 0 0 0 . 5

## Limit switch Type 055.009.6 (Contactless, Magnetic Field-resistant)



### Application

The magnetic field-resistant limit switch is used for monitoring and measuring axial or radial mechanical movements and adjustments e.g. on EAS®-clutches.

Magnetic field-resistant or welding-resistant proximity switches are used where strong magnetic fields can influence the function of the proximity switch. For example, they can be used in the field of strong magnetic coils as well as welding guns or welding electrodes with high welding currents.

### Function

When the sensor surface (damped) scans a metal control flag, the signal level changes from the applied U input voltage to 0 volt.



### Electrical connection

1	L+	BN (brown)
2	NC	BK (black)
3	L-	BU (blue)
4	not connected	

### Technical data

Size	M12 x 1
Type	Rustproof stainless steel, PTFE coated
Input voltage	10 – 30 VDC PELV
No-load current	≤ 20 mA
Power capacity	200 mA
Switching frequency	max. 1000 Hz
Contact	PNP NC, 3-wire sensor
Switching distance $S_n$	2 mm, flush installation
Secured switching distance $S_a$	1.6 mm
Repetitive accuracy	≤ 5 %
Characteristics	Reverse polarity protected, short-circuit-resistant, function indicator
Connection	Plug-in connector, cable 5 m / PUR
Tightening torque	40 Nm
Ambient temperature	-25 °C up to +100 °C
Protection	IP67

### Dimensions (mm)

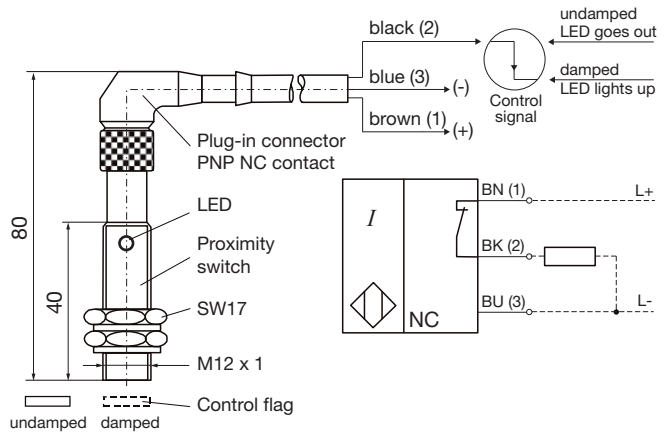

### Installation

See Limit Switch Installation, Figs. 4 and 5, page 14.

### Order Number

0 5 5 . 0 0 9 . 6 / \_

Connection Voltage [VDC]

10 up to 30

## Headquarters

Chr. Mayr GmbH + Co. KG  
Eichenstraße 1, D-87665 Mauerstetten  
Tel.: +49 83 41/8 04-0, Fax: +49 83 41/80 44 21  
www.mayr.com, E-Mail: public.mayr@mayr.com



## Service Germany/Austria

**Baden-Württemberg**  
Esslinger Straße 7  
70771 Leinfelden-Echterdingen  
Tel.: 07 11/78 26 26 40  
Fax: 07 11/78 26 26 39

**Bavaria**  
Industriestraße 51  
82194 Gröbenzell  
Tel.: 0 81 42/50 19 808

**Chemnitz**  
Bornauer Straße 205  
09114 Chemnitz  
Tel.: 03 71/4 74 18 96  
Fax: 03 71/4 74 18 95

**Franken**  
Unterer Markt 9  
91217 Hersbruck  
Tel.: 0 91 51/81 48 64  
Fax: 0 91 51/81 62 45

**Kamen**  
Herbert-Wehner-Straße 2  
59174 Kamen  
Tel.: 0 23 07/24 26 79  
Fax: 0 23 07/24 26 74

**North**  
Schiefer Brink 8  
32699 Extertal  
Tel.: 0 57 54/9 20 77  
Fax: 0 57 54/9 20 78

**Rhine-Main**  
Kohlhäuser Str. 3-5  
36043 Fulda  
Tel.: 06 61/96 21 02 15

**Austria**  
Pummerinplatz 1, TIZ I, A27  
4490 St. Florian, Austria  
Tel.: 0 72 24/2 20 81-12  
Fax: 0 72 24/2 20 81 89

## Branch office

**China**  
Mayr Zhangjiagang  
Power Transmission Co., Ltd.  
Fuxin Road No.1298, Yangshe Town  
215637 Zhangjiagang  
Tel.: 05 12/58 91-75 67  
Fax: 05 12/58 91-75 66  
info@mayr-ptc.cn

**France**  
Mayr France S.A.S.  
Z.A.L. du Minopole  
Rue Nungesser et Coli  
62160 Bully-Les-Mines  
Tel.: 03.21.72.91.91  
Fax: 03.21.29.71.77  
contact@mayr.fr

**Great Britain**  
Mayr Transmissions Ltd.  
Valley Road, Business Park  
Keighley, BD21 4LZ  
West Yorkshire  
Tel.: 0 15 35/66 39 00  
Fax: 0 15 35/66 32 61  
sales@mayr.co.uk

**Italy**  
Mayr Italia S.r.l.  
Viale Veneto, 3  
35020 Saonara (PD)  
Tel.: 049/879 10 20  
Fax: 049/879 10 22  
info@mayr-italia.it

**Japan**  
Mayr Japan LLC  
2F, 1-1-9 Nihonbashi Kakigara-cho,  
Chuo-ku Tokyo, 103-0014 Japan  
Tel.: 03/35 27-29 00  
Fax: 03/35 27-26 61  
public.mayr@mayr.co.jp

**Singapore**  
Mayr Transmission (S) PTE Ltd.  
No. 8 Boon Lay Way Unit 03-06,  
TradeHub 21  
Singapore 609964  
Tel.: 00 65/65 60 12 30  
Fax: 00 65/65 60 10 00  
info@mayr.com.sg

**Switzerland**  
Mayr Kupplungen AG  
Tobelackerstraße 11  
8212 Neuhausen am Rheinfall  
Tel.: 0 52/6 74 08 70  
Fax: 0 52/6 74 08 75  
info@mayr.ch

**USA**  
Mayr Corporation  
10 Industrial Avenue  
Mahwah  
NJ 07430  
Tel.: 2 01/4 45-72 10  
Fax: 2 01/4 45-80 19  
info@mayrcorp.com

## Representatives

**Australia**  
Drive Systems Pty Ltd.  
8/32 Melverton Drive  
Hallam, Victoria 3803  
Australia  
Tel.: 0 3/97 96 48 00  
info@drivesystems.com.au

**India**  
National Engineering  
Company (NENCO)  
J-225, M.I.D.C.  
Bhosari Pune 411026  
Tel.: 0 20/27 13 00 29  
Fax: 0 20/27 13 02 29  
nenco@nenco.org

**Netherlands**  
Groneman BV  
Amarilstraat 11  
7554 TV Hengelo OV  
Tel.: 074/2 55 11 40  
Fax: 074/2 55 11 09  
aandrijftechnik@groneman.nl

**Poland**  
Wamex Sp. z o.o.  
ul. Pozaryskiego, 28  
04-703 Warszawa  
Tel.: 0 22/6 15 90 80  
Fax: 0 22/8 15 61 80  
wamex@wamex.com.pl

**South Korea**  
Mayr Korea Co. Ltd.  
15, Yeondeok-ro 9beon-gil  
Seongsan-gu  
51571 Changwon-si  
Gyeongsangnam-do. Korea  
Tel.: 0 55/2 62-40 24  
Fax: 0 55/2 62-40 25  
info@mayrkorea.com

**Taiwan**  
German Tech  
Component Co., Ltd.  
No.10-3, Ln. 358, Sec. 1,  
Hemu Rd., Shengang Dist.,  
429012 Taichung City  
Tel.: +886 (4) 25150566  
Fax: +886 (4) 25152413  
abby@zfgta.com.tw

**Czech Republic**  
BMC - TECH s.r.o.  
Hviezdoslavova 29 b  
62700 Brno  
Tel.: 05/45 22 60 47  
Fax: 05/45 22 60 48  
info@bmc-tech.cz

**Turkey**  
Representative Office Turkey  
Kucukbakkalkoy Mah.  
Brandium Residence R2  
Blok D:254  
34750 Atasehir - Istanbul, Turkey  
Tel.: 02 16/2 32 20 44  
Fax: 02 16/5 04 41 72  
info@mayr.com.tr

## More representatives:

Belgium, Brazil, Canada, Colombia, Croatia, Denmark, Finland, Greece, Hongkong, Hungary, Indonesia, Israel, Luxembourg, Malaysia, Mexico, New Zealand, Norway, Philippines, Portugal, Romania, Russia, Slovakia, Slovenia, South Africa, Spain, Sweden, Thailand

You can find the complete contact details for the representative responsible for your area in the Contact section at [www.mayr.com](http://www.mayr.com)

