

# Installation and Operational Instructions for ROBATIC® Type 500.20\_.0 and Type 500.21\_.0 Sizes 3 to 7

(B.5.3.EN)

## Please read these Operational Instructions carefully and follow them accordingly!

Ignoring these Instructions may lead to malfunctions or to clutch failure, resulting in damage to other parts.  
These Installation and Operational Instructions (I + O) are part of the clutch delivery.  
Please keep them handy and near to the clutch at all times.

### Contents:

- Page 1:** - Contents  
- Safety and Guideline Signs  
- Guidelines on EU Directives
- Page 2:** - Safety Regulations
- Page 3:** - Safety Regulations
- Page 4:** - Safety Regulations
- Page 5:** - Clutch Illustrations  
- Parts List
- Page 6:** - Technical Data  
- Scope of Delivery / State of Delivery  
- Function  
- Design
- Page 7:** - Explanation of Terms  
- Torque Characteristics  
- Run-in Conditions
- Page 8:** - Installation Examples  
- Boring the Rotor Hub
- Page 9:** - Installation  
- Rotor De-installation  
- Electrical Connection  
- Maintenance and Inspection  
- Disposal
- Page 10:** - Malfunctions / Breakdowns

### Safety and Guideline Signs

#### DANGER



Immediate and impending danger, which can lead to severe physical injuries or to death.

#### CAUTION



Danger of injury to personnel and damage to machines.



**Please Observe!**  
Guidelines on important points.



According to German notation, decimal points in this document are represented with a comma (e.g. 0,5 instead of 0.5).



#### Guidelines on the Declaration of Conformity

A conformity evaluation has been carried out for the product (electromagnetic ROBATIC®-clutches) in terms of the EC low voltage directive 2006/95/EC. The Declaration of Conformity is laid out in writing in a separate document and can be requested if required.

#### Guidelines on the EMC Directive (2004/108/EC)

The product cannot be operated independently according to the EMC directive.

Due to their passive state, clutches are also non-critical equipment according to the EMC.

Only after integration of the product into an overall system can this be evaluated in terms of the EMC.

For electronic equipment, the evaluation has been verified for the individual product in laboratory conditions, but not in the overall system.

#### Guidelines on the Machinery Directive (2006/42/EC)

The product is a component for installation into machines according to the Machinery Directive 2006/42/EC.

The ROBATIC®-clutches can fulfil the specifications for safety-related applications in coordination with other elements.

The type and scope of the required measures result from the machine risk analysis.

The ROBATIC®-clutch then becomes a machine component and the machine manufacturer assesses the conformity of the safety device to the directive.

It is forbidden to start use of the product until you have ensured that the machine accords with the regulations stated in the directive.

#### Guidelines on the ATEX Directive

Without a conformity evaluation, this product is not suitable for use in areas where there is a high danger of explosion.

For application of this product in areas where there is a high danger of explosion, it must be classified and marked according to directive 94/9/EC.

## Safety Regulations

These Safety Regulations are user hints only and may not be complete!

### General Guidelines

#### DANGER



Danger of death!  
Do not touch voltage-carrying cables and components.

Clutches may generate further risks, among other things:



Hand-  
injuries



Danger of  
seizure



Contact with  
hot  
surfaces



Magnetic  
fields

#### Severe injury to people and damage to objects may result if:

- The electromagnetic clutch is used incorrectly.
- The electromagnetic clutch is modified.
- If the relevant standards for safety and / or installation conditions are ignored.

During the required risk assessment when designing the machine or system, the dangers involved must be evaluated and removed by taking appropriate protective measures.

**To prevent injury or damage, only professionals and specialists are allowed to work on the devices.** They must be familiar with the dimensioning, transport, installation, initial operation, maintenance and disposal according to the relevant standards and regulations.



Before product installation and initial operation, please read the Installation and Operational Instructions carefully and observe the Safety Regulations. Incorrect operation can cause injury or damage.

At the time these Installation and Operational Instructions go to print, the electromagnetic clutches accord with the known technical specifications and are operationally safe at the time of delivery.

- Technical data and specifications (Type tags and Documentation) must be followed.
- The correct connection voltage must be connected according to the Type tag and wiring guidelines.
- Check electrical components for signs of damage before putting them into operation. Never bring them into contact with water or other fluids.
- Please observe the EN 60204-1 requirements for electrical connection when using in machines.



Only carry out installation, maintenance and repairs in a de-energised, disengaged state and secure the system against inadvertent switch-on.

### Guidelines for Electromagnetic Compatibility (EMC)

In accordance with the EMC directives 2004/108/EC, the individual components produce no emissions. However, functional components e.g. mains-side energisation of the clutches with rectifiers, phase demodulators, ROBA®-switch devices or similar controls can produce disturbance which lies above the allowed limit values. For this reason it is important to read the Installation and Operational Instructions very carefully and to keep to the EMC directives.

### Application Conditions



The catalogue values are guideline values which have been determined in test facilities. It may be necessary to carry out your own tests for the intended application. When dimensioning the clutches, please remember that installation situations, torque fluctuations, permitted friction work, run-in behaviour and wear as well as general ambient conditions can all affect the given values. These factors should therefore be carefully assessed, and alignments made accordingly.

- Mounting dimensions and connection dimensions must be adjusted according to the size of the clutch at the place of installation.
- Use of the clutch in extreme environmental conditions or outdoors, directly exposed to the weather, is not permitted.
- The clutches are designed for a relative duty cycle of 100 %.
- The torque is dependent on the present run-in condition of the clutch.
- The clutches are only designed for dry running. The torque is lost if the friction surfaces come into contact with oil, grease, water or similar substances or foreign bodies.

#### CAUTION



The friction surfaces may rust up and seize up in corrosive ambient conditions and/or after longer downtimes. The user is responsible for taking appropriate countermeasures.

## Safety Regulations

These Safety Regulations are user hints only and may not be complete!

### Ambient Temperature: -20 °C up to +40 °C

#### CAUTION



At temperatures of around or under freezing point, both condensation and the special characteristics of the linings (lower friction values at lower temperatures) can strongly reduce the torque.

The user is responsible for taking respective countermeasures, e.g. selecting clutches with higher nominal braking torques. Frequent and extensive temperature fluctuations at high humidity promote the formation of corrosion, which can lead to seized linings. The clutch function must be inspected both once attachment has taken place as well as after longer system downtimes, in order to prevent the drive starting up against possibly seized linings. The customer is responsible for providing a protective cover against contamination caused by construction sites.

### Intended Use

ROBATIC®-clutches have been developed, manufactured and tested in compliance with the DIN VDE 0580 standard and in accordance with the EU Low Voltage Directive as electromagnetic components. During installation, operation and maintenance of the product, the requirements for the standard must be observed.

ROBATIC®-clutches are for use in machines and systems and must only be used in the situations for which they are ordered and confirmed. Using them for any other purpose is not allowed.

### Earthing Connection

The clutch is designed for Protection Class I. This protection covers not only the basic insulation, but also the connection of all conductive parts to the protective conductor (PE) on the fixed installation. If the basic insulation fails, no contact voltage will remain. Please carry out a standardised inspection of the protective conductor connections to all contactable metal parts!

### Class of Insulation F (+155 °C)

The insulation components on the magnetic coils are manufactured at least to class of insulation F (+155 °C).

### Protection

**(electrical) IP54:** Dust-proof and protected against contact as well as against water spray from any direction.

Valid for coil, casting compound and connection strands.

**On the design with a connection terminal, the connection terminal itself corresponds to Protection IP 00.**

### Storage

- Store the clutches in a horizontal position, in dry rooms and dust and vibration-free.
- Relative air humidity < 50 %.
- Temperature without major fluctuations within a range from -20 ° up to +60 °C.
- Do not store in direct sunlight or UV light.
- Do not store aggressive, corrosive substances (solvents / acids / lyes / salts etc.) near to the brakes.

For longer storage of more than 2 years, special measures are required (please contact the manufacturer).

### Handling

**Before installation**, the clutch must be inspected and found to be in proper condition.

The clutch function must be inspected both **once attachment has taken place** as well as **after longer system downtimes**, in order to prevent the drive starting up against possibly seized linings.

### User-implemented Protective Measures:

- Please cover moving parts to protect **against injury through seizure**.
- Place a cover on the magnetic part to protect **against injury through high temperatures**.
- Protection circuit:** When using DC-side switching, the coil must be protected by a suitable protection circuit according to VDE 0580, which is integrated in *mayr*®-rectifiers. To protect the switching contact from consumption when using DC-side switching, additional protective measures are necessary (e.g. series connection of switching contacts). The switching contacts used should have a minimum contact opening of 3 mm and should be suitable for inductive load switching. Please make sure on selection that the rated voltage and the rated operating current are sufficient. Depending on the application, the switching contact can also be protected by other protection circuits (e.g. *mayr*®-spark quenching unit, half-wave and bridge rectifiers), although this may of course then alter the switching times.
- Take precautions **against freeze-up of the friction surfaces** in high humidity and at low temperatures.

## Safety Regulations

These Safety Regulations are user hints only and may not be complete!

### Regulations, Standards and Directives Used

DIN VDE 0580	Electromagnetic devices and components, general specifications
2006/95/EC	Low voltage directive
CSA C22.2 No. 14-2010	Industrial Control Equipment
UL 508 (Edition 17)	Industrial Control Equipment
EN ISO 12100	Safety of machinery – General principles for design - Risk assessment and risk reduction
DIN EN 61000-6-4	Interference emission
DIN EN 61000-6-2	Interference immunity
EN 60204-1	Electrical equipment of machines

### Liability

The information, guidelines and technical data in these documents were up to date at the time of printing. Demands on previously delivered clutches are not valid.

Liability for damage and operational malfunctions will not be taken if:

- the Installation and Operational Instructions are ignored or neglected.
- the clutches are used inappropriately.
- the clutches are modified.
- the clutches are worked on unprofessionally.
- the clutches are handled or operated incorrectly.

### Guarantee

- The guarantee conditions correspond with the Chr. Mayr GmbH + Co. KG sales and delivery conditions.
- Mistakes or deficiencies are to be reported to *mayr*® at once!

### CE Identification

 according to the Low voltage directive 2006/95/EC

### Identification

*mayr*® components are clearly marked and described on the Type tag:

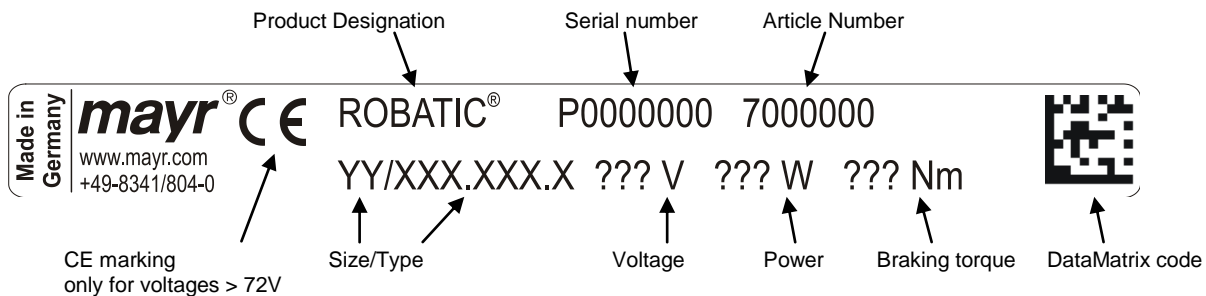

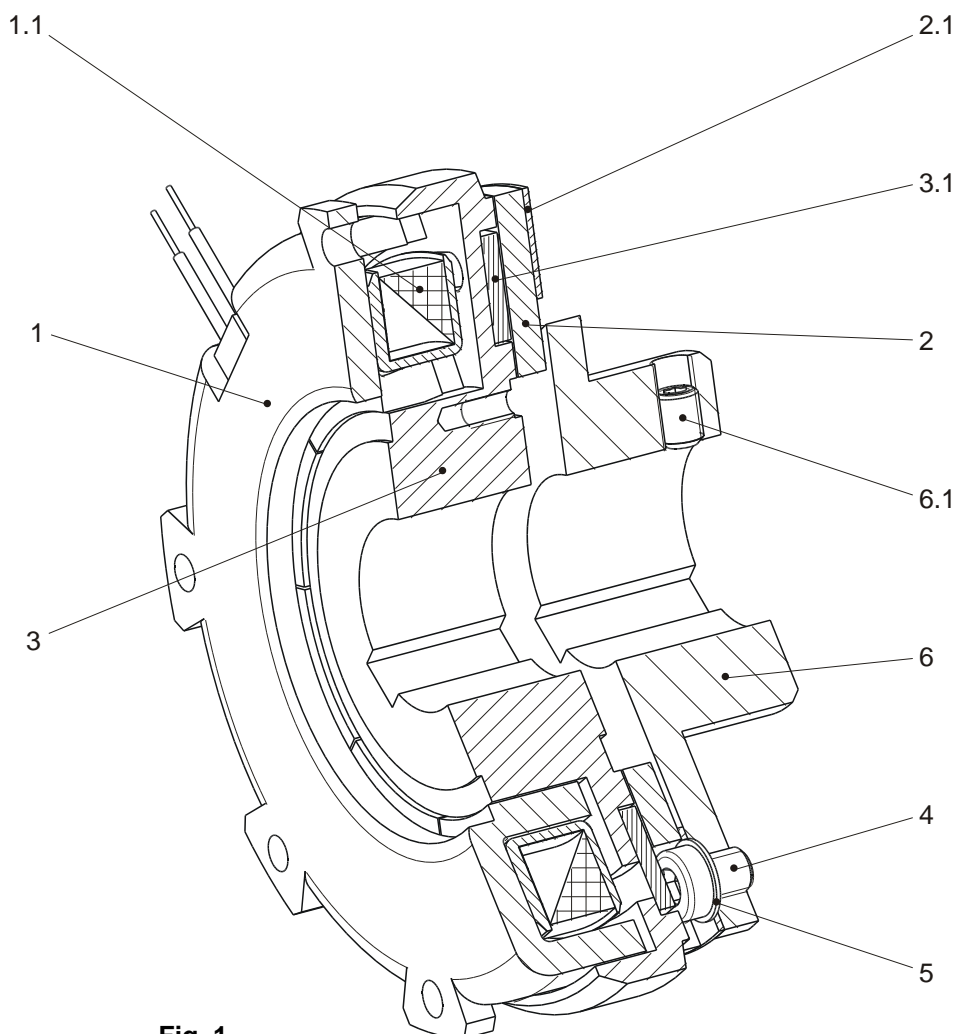

**Fig. 1**

**Parts List**

(Only use *mayr*® original parts)

Item	Name
1	Coil carrier assembly with type tag
1.1	Magnetic coil
2	Armature disk assembly
2.1	Transmission spring
3	Rotor assembly
3.1	Friction lining
4	Cap screw <sup>1)</sup>
5	Spring washer
6	Flange hub (dependent on Type)
6.1	Set screw <sup>1)</sup> (dependent on Type)



<sup>1)</sup> Secure the cap screws Item 4 and the set screw Item 6.1 with Loctite 243

# Installation and Operational Instructions for ROBATIC® Type 500.20\_.\_0 and Type 500.21\_.\_0 Sizes 3 to 7

(B.5.3.EN)

Table 1: Technical Data

	Size	3	4	5	6	7
Nominal torque $M_2$ <sup>2)</sup>	[Nm]	10	20	45	80	160
Maximum bore $d_{max}$ in rotor (3) on Type 500.20_.__	[mm]	25	35	42	55	65
Maximum bore $d_{max}$ in rotor (3) on Type 500.21_.__	[mm]	20	28	35	42	55
Air gap "a" (Figs. 3 / 4)	[mm]	0,2 <sup>+0,1</sup> <sub>-0,05</sub>	0,2 <sup>+0,15</sup> <sub>-0,05</sub>	0,2 <sup>+0,15</sup> <sub>-0,05</sub>	0,3 <sup>+0,15</sup> <sub>-0,05</sub>	0,3 <sup>+0,15</sup> <sub>-0,05</sub>
Maximum working air gap	[mm]	0,6	0,8	1,0	1,2	1,5
Max. permitted centre offset "V" (Figs. 5 / 6)	[mm]	0,05	0,05	0,05	0,05	0,1
Max. permitted centre offset "V <sub>1</sub> " (Figs. 5 / 6)	[mm]	0,1	0,15	0,15	0,15	0,2
Diameter "H" (Fig. 5)	[mm]	80 h9	100 h9	125 h9	150 h9	190 h9
Diameter "Z" (Fig. 5) on Type 500.20_.__	[mm]	42 H8	52 H8	62 H8	80 H8	100 H8
Diameter "Z" (Fig. 5) on Type 500.21_.__	[mm]	35 H8	42 H8	52 H8	62 H8	80 H8
Dimension "z" (Fig. 6) on Type 500.20_.__	[mm]	3,5	4,5	5	6	6
Dimension "z" (Fig. 6) on Type 500.21_.__	[mm]	2	2,5	3	3,5	3,5
Tightening torque cap screws (4) <sup>3)</sup> on Type 500.20_.__	[Nm]	2,9	5,7	9,9	24	24
Tightening torque cap screws (4) <sup>3)</sup> on Type 500.21_.__	[Nm]	1,1	2,9	5,7	9,9	24
Tightening torque fixing screws <sup>4)</sup> for coil carrier on all Types [Nm]	[Nm]	2,9	5,7	9,9	9,9	24

<sup>2)</sup> Please observe run-in specifications and minimum speed acc. Table 2

<sup>3)</sup> Secure the cap screws Item 4 with Loctite 243

<sup>4)</sup> Not included in the standard scope of delivery

## Scope of Delivery / State of Delivery

Please check the scope of delivery according to the Parts List as well as the state of delivery immediately after receiving the goods.

mayr® will grant no guarantee for belated complaints.

Please report transport damage immediately to the deliverer.

Please report incomplete delivery and obvious defects immediately to the manufacturer.

## Function

ROBATIC®-clutches are "energised to engage", electromagnetic pole face clutches.

When DC voltage is applied to the magnetic coil in the coil carrier (1), a magnetic field is built up. The armature disk (2) is attracted to the rotor (3).

The torque is transmitted via frictional locking.



In new condition, torque transmission first takes place via the metal outer pole on the rotor (3) and, after a short operation period, then additionally via the inner pole. After the entire run-in procedure, an even frictional combination occurs on the metal poles and on the friction lining (3.1) lying between them. The full transmittable nominal torque is not achieved until after the run-in procedure has been carried out as described below.

## Design

ROBATIC®-clutches have Electrical Protection IP 54 and Insulation Material Class F (up to 155 °C) for coil, casting compound and connection strands. On the design with a connection terminal, the connection terminal itself corresponds to Protection IP 00.

### DANGER



At 100 % duty cycle, the coil carrier has a temperature of approx. 65 °C.  
Do not touch the clutch!  
=> Danger of burns!

The surfaces on the coil carrier (1), rotor (3) and flange hub (6) are phosphated, the armature disk (2) is gas nitro-carburized or plasma-nitrided (friction surfaces are ground), and the transmission spring (2.1) is made of stainless steel.

The clutch rotor (3) is supplied either pilot bored or finish bored with a keyway acc. DIN 6885. When the rotor bore and keyway are produced customer-side, the Guidelines on page 8 "Boring the Rotor Hub" must be followed!

# Installation and Operational Instructions for ROBATIC® Type 500.20\_.0 and Type 500.21\_.0 Sizes 3 to 7

(B.5.3.EN)

## Explanation of Terms

The **nominal torque  $M_2$**  is the largest transmittable torque (after run-in has been completed), with which the closed clutch can be loaded without slipping occurring.

The **relative duty cycle** is the ratio of duty cycle to cycle time in percent (% duty cycle).

## Torque Characteristics

**In new condition, approx. 50 % of the catalogue nominal torque ( $M_2$ ) is transmitted.**

The components reach the catalogue nominal torque when the friction surfaces are run in. As a rough guideline value, approx. 100 – 200 switchings in dynamic operation, a typical speed of approx. 500 to 1000 rpm and a medium friction work (see Table 2) can be given.

Longer slipping of the clutch is to be avoided, especially at low speeds, as this can cause scoring formation and therefore damage to the friction surfaces.

Clutches used in static or virtually static operation do not reach the nominal torque ( $M_2$ ) stated in the Technical Data (Table 1).

If requested, the clutches can also be run in at the place of manufacture. For this, please ensure exact installation customer-side according to the specifications in order to reproduce the friction conditions as precisely as possible. At the same time, the "friction carbon" produced must not be rubbed off.

If the clutches are run in to the nominal torque at the place of manufacture and then operated in static or virtually static mode, please allow for a drop to approx. 60 – 70 % of the nominal torque. This is the case if the clutch falls below the speed or friction work ( $Q_a$ ) stated in Table 2.

For static and virtually static applications, we therefore recommend our "double-flow designs", Type series 500.3\_..0.

**Table 2**

Size	Friction work $Q_a$ [J]	Clutch speed $n_{min}$ [rpm]
3	16	300
4	29	250
5	55	200
6	105	160
7	200	130

## Run-in Conditions

An "artificial" run-in is to be carried out if a run-in procedure is not possible in the machine due to the type of application (see Section "Torque Characteristics"), e. g. due to insufficient friction work, speed or switching frequencies.



Only carry out the torque inspection in static operation - no slipping (danger of scoring)

### Run-in Possibility 1

- Apply a voltage approx. 1/2 – 1/3 of  $U_{Nenn}$ .
- Speed approx. 200 – 500 rpm
- Synchronise against blocked output  
Cycle approx. 50 – 100 ms (dependent on Size);  
No prolonged slipping; break approx. 200 ms  
Synchronise approx. 2 – 3 minutes (100 – 200 cycles)

### Run-in Possibility 2

- Synchronise against unblocked output by producing a larger rotating mass and / or  
by synchronising at higher speed (values should lie above the minimum values, Table 2)
- Allow to synchronise approx. 2 – 3 minutes

# Installation and Operational Instructions for ROBATIC® Type 500.20\_.0 and Type 500.21\_.0 Sizes 3 to 7

(B.5.3.EN)

## Installation Example 1 (Fig. 3)



The Items 7 to 10 are customer-side mounting parts which are not included in the standard scope of delivery.

In operation, the armature disk (2) is attracted to the rotor (3). The torque is transmitted via frictional locking from the drive shaft (8) via the rotor (3) and the armature disk (2) onto the V-belt disk (7).

The coil carrier (1) is screwed onto the machine wall, centred onto the shaft bearing (9).

The air gap "a" between the rotor (3) and the armature disk (2) is defined via the distance ring (10) between the rotor (3) and the V-belt disk bearing (7).

The V-belt disk (7) should be made from a material which is a poor magnetic conductor in order to prevent magnetic loss due to leaking flux and therefore loss of force.

## Installation Example 2 (Fig. 4)

Electromagnetic clutch with flange hub (6) for the connection of two aligning shafts.

### Torque Course:

Input shaft – rotor (3) – armature disk (2) – flange hub (6) – output shaft.

The coil carrier (1) and the rotor (3) are mounted input-side, the flange hub (6) with the screwed-on armature disk (2) is mounted onto the output shaft.

Axial securement of the rotor (3) takes place via a press cover and a screw, screwed into the shaft threaded centre hole. A set screw (6.1) secures the flange hub (6) onto the output shaft. For adjustment of air gap "a" between the rotor (3) and the armature disk (2), the set screw (6.1) is loosened and the flange hub (6) is moved onto the output shaft.

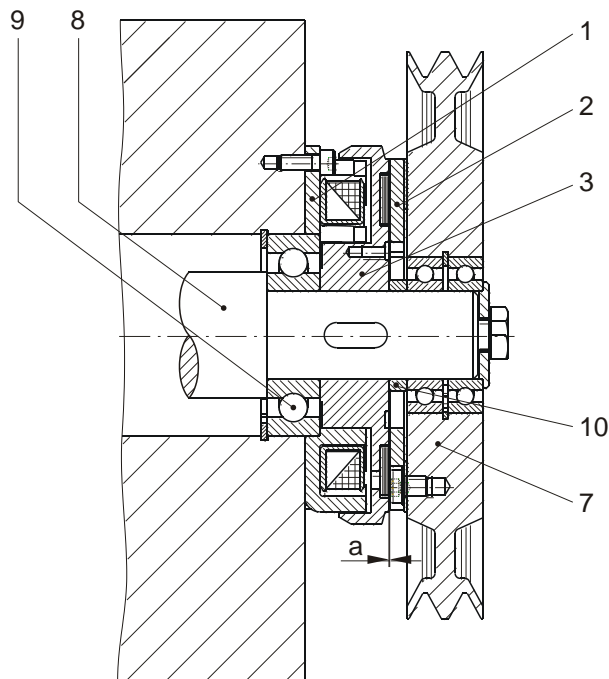

Fig. 3

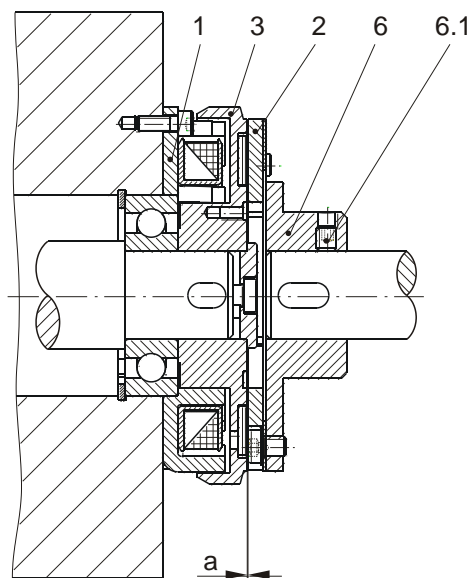

Fig. 4

## Boring the Rotor Hub (Fig. 2)

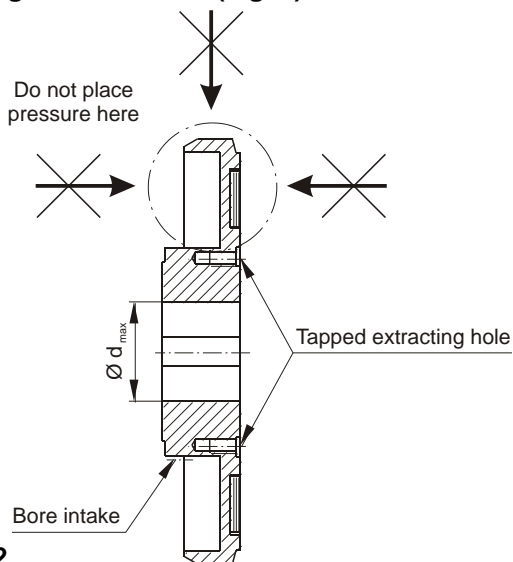

Fig. 2

The rotor (3) must not be bent during boring. Do not place pressure on the outer, thin-walled rotor area, see Fig. 2.

To bore, clamp on the rotor hub.

The max. permitted bore diameter  $d_{max.}$  according to Table 1, must not be exceeded. The keyway is produced according to DIN 6885.

We recommend H7/k6 as a suitable hub-shaft tolerance.



# Installation and Operational Instructions for ROBATIC® Type 500.20\_0 and Type 500.21\_0 Sizes 3 to 7

(B.5.3.EN)

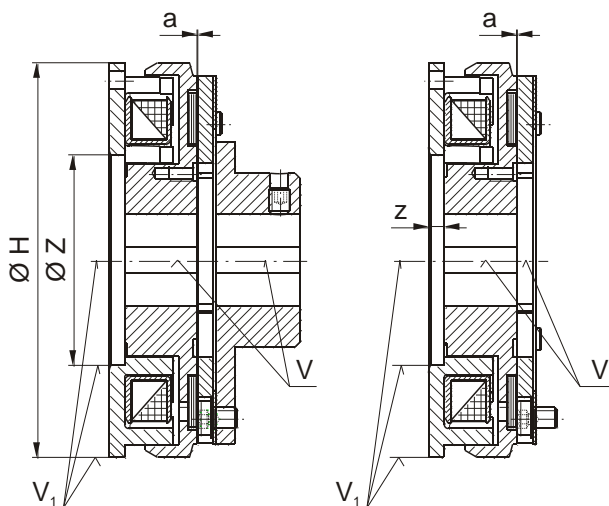

Fig. 5

Fig. 6

## Installation

### 1. Mounting the coil carrier (1):

Screw the coil carrier (1) onto the machine wall (observe the tightening torque acc. Table 1).

- Centred by a ball bearing (9), Figs. 3/4.
- Centred on diameter "Z", Fig. 5 and Table 1.
- Centred on outer diameter "H", Fig. 5.

The maximum permitted centre offset "V<sub>1</sub>" acc. Table 1 may not be exceeded (Figs. 5 and 6).

### 2. Installation of the rotor (3):

The rotor (3) is mounted onto the shaft using a suitable fitting device.



- Do not place pressure on the outer area of the rotor (3).
- Do not mount by hitting with a hammer.
- Keep to dimension "z", Table 1 and Fig. 6.
- The rotor (3) must be kept grease-free.

The rotor (3) must be secured axially in operation, see Installation Examples Figs. 3 and 4.

Axial backlash can lead to the rotor (3) rubbing against the armature disk (2) or the coil carrier (1).

### 3. Installation of the armature disk (2):



The armature disk (2) must be kept grease-free.

- 3.1. Lay the spring washers (5) under the cap screws (4). The cap screws (4) must be secured with Loctite 243.
- 3.2. Mount the armature disk (2) onto the mounting part or onto the flange hub (6) (observe the tightening torque acc. Table 1).
- 3.3. Align the armature disk (2) (max. permitted radial run-out 0,15 mm).

### 4. Installation of the mounting part or the flange hub (6):

- 4.1. Adjust the air gap "a" according to Table 1 and Figs. 3/4.
- 4.2. Secure the mounting part or flange hub (6) axially backlash-free.  
Axial backlash changes the air gap "a" and can lead to the rotor (3) rubbing against the armature disk (2) (see Installation Examples Figs. 3 and 4).  
Please observe the maximum permitted centre offset "V" according to Table 1 and Figs. 5 and 6.  
The flange hub (6) must be secured axially onto the shaft using the set screw (6.1). Furthermore, the set screw (6.1) must be secured with Loctite 243.

## Rotor De-installation (Fig. 2 / Page 6)

In order to remove the rotor (3) from the shaft, there are threaded holes in the rotor hub.

Do not place pressure on the outer, thin-walled rotor (3) area.

## Electrical Connection

The clutch coil is connected to a DC voltage supply. The voltage value is stated on the Type tag.

## Maintenance and Inspection

Please inspect the air gap "a" and the permitted centre offsets "V" and "V<sub>1</sub>" according to Table 1 at regular intervals. Bearing backlash and wear on the friction surfaces alter the permitted Table values. Apart from this, ROBATIC®-electromagnetic clutches are maintenance-free.

## Disposal

Our electromagnetic clutch components must be disposed of separately as they consist of different materials. Please also observe the relevant authority regulations. Code numbers may vary according to the disassembling process (metal, plastic and cables).

### Electronic components

(Rectifier / ROBA®-switch):

Products which have not been disassembled can be disposed of under Code No. 160214 (mixed materials) or components under Code No. 160216, or can be disposed of by a certified disposal firm.

### Coil carriers (steel pads with coils and strands) and all other steel components:

Steel scrap (Code No. 160117)

### Clutch rotors (steel pads with friction linings):

Brake linings (Code No. 160112)

# Installation and Operational Instructions for ROBATIC® Type 500.20\_.0 and Type 500.21\_.0 Sizes 3 to 7

(B.5.3.EN)

## Malfunctions / Breakdowns

Malfunction	Possible Causes	Solutions
Torque too low	<input type="checkbox"/> The permitted offsets V or V1 are exceeded	<input type="checkbox"/> Align the clutch
Clutch does not couple	<input type="checkbox"/> Incorrect voltage applied <input type="checkbox"/> Rectifier failure <input type="checkbox"/> Air gap too large <input type="checkbox"/> Grease and / or oil on the friction surfaces <input type="checkbox"/> Coil interrupted	<input type="checkbox"/> Apply correct voltage <input type="checkbox"/> Replace rectifier <input type="checkbox"/> Re-adjust the air gap <input type="checkbox"/> De-grease the friction surfaces <input type="checkbox"/> Replace the clutch
Clutch does not disengage	<input type="checkbox"/> Grease and / or oil on the friction surfaces	<input type="checkbox"/> De-grease the friction surfaces/ run in clutch again



mayr® will take no responsibility or guarantee for replacement parts and accessories which have not been delivered by mayr®, or for damage resulting from the use of these products.