

Please read these Operational Instructions carefully and follow them accordingly!

Ignoring these Instructions may lead to malfunctions or to clutch failure, resulting in damage to other parts.
These Installation and Operational Instructions (I + O) are part of the clutch delivery.
Please keep them handy and near to the clutch at all times.

Contents:

- Page 1:** - Contents
- Safety and Guideline Signs
- Guidelines on EU Directives
- Page 2:** - Safety Regulations
- Page 3:** - Safety Regulations
- Page 4:** - Safety Regulations
- Page 5:** - Clutch Illustrations
- Page 6:** - Parts List
- Table 1: Technical Data
- Page 7:** - State of Delivery
- Function
- Design
- Explanation of Terms
- Torque Characteristics
- Table 2: Technical Data for Run-in Procedure
- Page 8:** - Run-in Conditions
- General Installation Guidelines
- Boring the Rotor Hub
- Page 9:** - Installation of Type 540.100
- Installation of Type 540.140
- Clutch Installation
- Electrical Connection
- Maintenance and Checks
- Page 10:** - Disposal
- Malfunctions / Breakdowns

Safety and Guideline Signs

DANGER



Immediate and impending danger which can lead to severe physical injuries or to death.

CAUTION



Danger of injury to personnel and damage to machines.



Please Observe!
Guidelines on important points.



According to German notation, decimal points in this document are represented with a comma (e.g. 0,5 instead of 0.5).



Guidelines on the Declaration of Conformity

A conformity evaluation has been carried out for the product (electromagnetic ROBATIC®-clutch devices) according to the EC Low Voltage Directive 2006/95/EC. The declaration of conformity is set out in writing in a separate document and can be requested if required.

Guidelines on the EMC Directive (2004/108/EC)

The product cannot be operated independently according to the EMC directive.

Due to their passive state, ROBATIC®-clutches are also non-critical equipment according to the EMC.

Only after integration of the product into an overall system can they be evaluated in terms of the EMC.

For electronic equipment, the evaluation has been verified for the individual product in laboratory conditions, but not in the overall system.

Guidelines on the Machinery Directive (2006/42/EC)

The product is a component for installation into machines according to the Machine Directive 2006/42/EC.

ROBATIC®-clutches can fulfil the specifications for safety-related applications in coordination with other elements.

The type and scope of the required measures result from the machine risk analysis.

The ROBATIC®-clutch then becomes a machine component and the machine manufacturer assesses the conformity of the safety device to the directive.

It is forbidden to start use of the product until you have ensured that the machine accords with the regulations stated in the directive.

Guidelines on the ATEX Directive

Without a conformity evaluation, this product is not suitable for use in areas where there is a high danger of explosion.

For application of this product in areas where there is a high danger of explosion, it must be classified and marked according to directive 94/9/EC.

Safety Regulations

These Safety Regulations are user hints only and may not be complete!

General Guidelines

DANGER



Danger of death!
Do not touch voltage-carrying cables and components.

Clutches may generate further risks, among other things:



Hand injuries



Danger of seizure



Contact with hot surfaces



Magnetic fields

Severe injury to people and damage to objects may result if:

- the electromagnetic clutch is used incorrectly.
- the electromagnetic clutch is modified.
- the relevant standards for safety and / or installation conditions are ignored.

During the required risk assessment when designing the machine or system, the dangers involved must be evaluated and removed by taking appropriate protective measures.

To prevent injury or damage, only professionals and specialists are allowed to work on the devices.

They must be familiar with the dimensioning, transport, installation, initial operation, maintenance and disposal according to the relevant standards and regulations.



Before product installation and initial operation, please read the Installation and Operational Instructions carefully and observe the Safety Regulations. Incorrect operation can cause injury or damage.

The electromagnetic clutches have been developed and manufactured in accordance with the known technical specifications and are operationally safe at the time of delivery.

- Technical data and specifications (Type tags and documentation) must be followed.
- The correct connection voltage must be connected according to the Type tag and wiring guidelines.
- Check electrical components for signs of damage before putting them into operation. Never bring them into contact with water or other fluids.
- Please observe the EN 60204-1 requirements for electrical connection when using in machines.



Only carry out installation, maintenance and repairs in a de-energised, released state and secure the system against inadvertent switch-on.

Guidelines for Electromagnetic Compatibility (EMC)

In accordance with the EMC directive 2004/108/EC, the individual components produce no emissions. However, functional components e.g. mains-side energisation of the clutches with rectifiers, phase demodulators, ROBA®-switch devices or similar controls can produce disturbance which lies above the allowed limit values.

For this reason it is important to read the Installation and Operational Instructions very carefully and to keep to the EMC directives.

Application Conditions



The catalogue values are guideline values which have been determined in test facilities. It may be necessary to carry out your own tests for the intended application. When dimensioning the clutches, please remember that installation situations, torque fluctuations, permitted friction work, run-in behaviour and wear as well as general ambient conditions can all affect the given values. These factors should therefore be carefully assessed, and alignments made accordingly.

- Mounting dimensions and connecting dimensions must be adjusted according to the size of the clutch at the place of installation.
- The magnetic coils are designed for a relative duty cycle of 100 %.
- The torque is dependent on the present run-in condition of the clutches.
- The clutches are only designed for dry running. The torque is lost if the friction surfaces come into contact with oil, grease, water or similar substances or foreign bodies.
- The surfaces of the outer components have been zinc phosphated manufacturer-side to form a basic corrosion protection.

CAUTION



The rotors may rust up and block in corrosive ambient conditions and/or after long periods of storage.
The user is responsible for taking appropriate counter measures.

Safety Regulations

These Safety Regulations are user hints only and may not be complete!

Ambient Temperature: – 20 °C up to + 40 °C

CAUTION



At temperatures of around or under freezing point, condensation can strongly reduce the torque, or the friction surfaces can freeze up. The user is responsible for taking appropriate counter measures.

Appointed Use

ROBATIC®-clutches have been developed, manufactured and tested as electromagnetic components in compliance with the DIN VDE 0580 standard and in accordance with the EU Low Voltage Directive. During installation, operation and maintenance of the product, the requirements for the standard must be observed.

ROBATIC®-clutches are for use in machines and systems and must only be used in the situations for which they are ordered and confirmed. Using them for any other purpose is not allowed!

Earthing Connection

The clutch is designed for Protection Class I. This protection covers not only the basic insulation, but also the connection of all conductive parts to the PE conductor on the fixed installation. If the basic insulation fails, no contact voltage will remain. Please carry out a standardized inspection of the PE conductor connections to all contactable metal parts!

Insulation Material Class F (+155 °C)

The insulation components on the magnetic coils are manufactured at least to insulation material class F (+155 °C).

Protection

(electrical) IP54: Dust-proof and protected against contact as well as against water spray coming from any direction. This protection is valid for the coil, the casting compound and the connection strands.

On designs with a connection terminal, the connection terminal itself corresponds to Protection IP00.

Storage of ROBATIC®-clutch Devices

- Store the clutches in a horizontal position, in dry rooms and dust and vibration-free.
- Relative air humidity < 50 %.
- Temperature without major fluctuations within a range from – 20 ° up to +60°C.
- Do not store in direct sunlight or UV light.
- Do not store aggressive, corrosive substances (solvents / acids / lyes / salts etc.) near to the clutches.

For longer storage of more than 2 years, special measures are required (please contact the manufacturer).

Handling

Before installation, the clutch must be inspected and found to be in proper condition.

The clutch function must be inspected both **once installation has taken place** as well as **after longer system downtimes**, in order to prevent the drive starting up against possibly seized friction surfaces.

User-implemented Protective Measures:

- Please cover moving parts to protect **against injury through seizure**.
- Place a cover on the magnetic part to protect **against injury through high temperatures**.
- Protective circuit:** When using DC-side switching, the coil must be protected by a suitable protective circuit according to VDE 0580, which is integrated in *mayr*®-rectifiers. To protect the switching contact from consumption when using DC-side switching, additional protective measures are necessary (e.g. series connection of switching contacts). The switching contacts used should have a minimum contact opening of 3 mm and should be suitable for inductive load switching. Please make sure on selection that the rated voltage and the rated operation current are sufficient. Depending on the application, the switching contact can also be protected by other protective circuits (e.g. *mayr*®-spark quenching unit, half-wave and bridge rectifiers), although this may of course then alter the switching times.
- Install additional protective measures **against corrosion** if the clutch is subject to extreme ambient conditions or is installed in open air conditions, unprotected from the weather.
- Take precautions **against freeze-up of the friction surfaces** in high humidity and at low temperatures.

Regulations, Standards and Directives Used:

DIN VDE 0580	Electromagnetic devices and components, general directives
2006/95/EC	Low voltage directive

Please Observe the Following Standards:

DIN EN ISO 12100-1 and 2	Machine safety
DIN EN ISO 14121-1	Risk assessment
DIN EN 61000-6-4	Noise emission
DIN EN 61000-6-2	Interference immunity
EN 60204	Electrical machine equipment

Safety Regulations

These Safety Regulations are user hints only and may not be complete!

Liability

The information, guidelines and technical data in these documents were up to date at the time of printing. Demands on previously delivered clutches are not valid.

Liability for damage and operational malfunctions will not be taken if:

- the Installation and Operational Instructions are ignored or neglected.
- the clutches are used inappropriately.
- the clutches are modified.
- the clutches are worked on unprofessionally.
- the clutches are handled or operated incorrectly.

Guarantee

- The guarantee conditions correspond with the Chr. Mayr GmbH + Co. KG sales and delivery conditions.
- Mistakes or deficiencies are to be reported to *mayr*® at once!

Conformity Markings

CE according to the Low Voltage Directive 2006/95/EC

Identification

mayr® components are clearly marked and described on the Type tag:

Manufacturer

***mayr*®**

Name/Type

Article number

Serial number

Installation and Operational Instructions for ROBATIC®-clutch Type 540.1 _ _ Sizes 3 – 9

(B.5.1.GB)

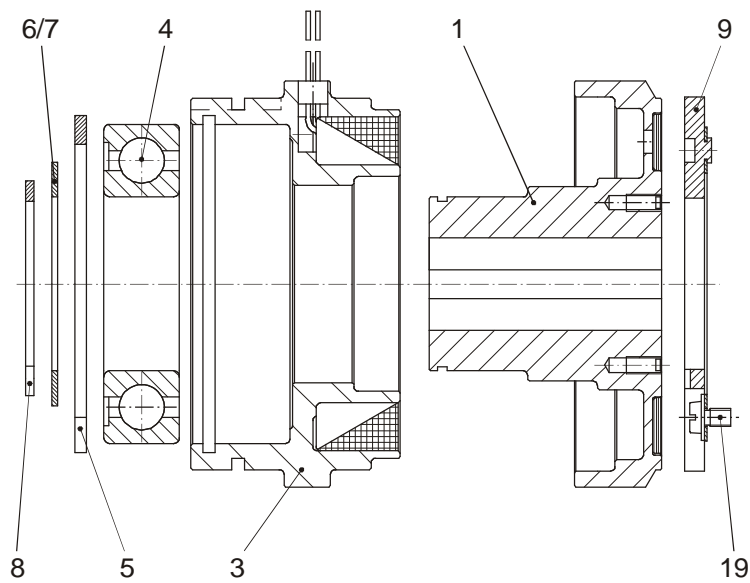

Fig. 1: Type 540.100

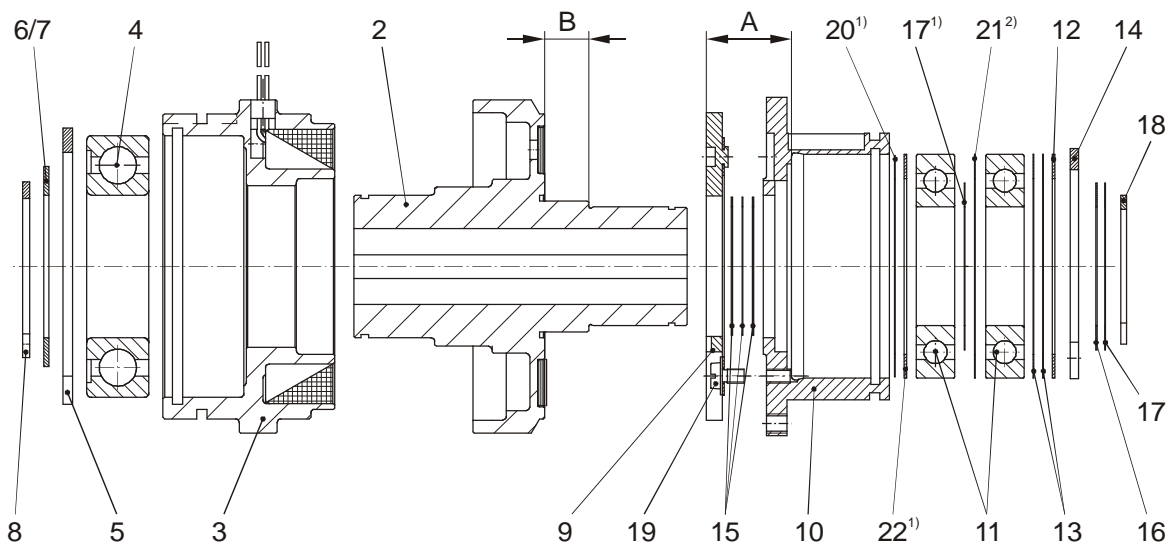

Fig. 2: Type 540.140

¹⁾ Only for Sizes 7 to 9

²⁾ Only for Sizes 3 to 6 (on Sizes 3 and 4: 0,1 mm thick; on Sizes 5 and 6: 0,15 mm thick)

Installation and Operational Instructions for ROBATIC®-clutch Type 540.1 _ _ Sizes 3 – 9

(B.5.1.GB)

Parts List (Only use mayr® original parts)

Item	Name
1	Rotor Type 540.100
2	Rotor Type 540.140
3	Coil carrier
4	Deep groove ball bearing
5	Locking ring
6	Shim ring
7	Shim ring
8	Locking ring
9	Armature disk inc. transmission spring
10	Driver flange
11	Deep groove ball bearing

Item	Name
12	Shim ring
13	Shim ring
14	Locking ring
15	Shim ring
16	Shim ring
17	Shim ring
18	Locking ring
19	Cap screw
20	Ball bearing compensation disk
21	Shim ring
22	Shim ring

Table 1: Technical Data

	Size	3	4	5	6	7	8	9
Nominal torque M_2 ³⁾	[Nm]	10	20	45	80	160 ⁴⁾	320 ⁴⁾	640 ⁴⁾
Maximum bore d_{max} in rotor (1)	[mm]	20	25	30	40	55	70	80
Maximum bore d_{max} in rotor (2)	[mm]	15	19	24	33	46	58	65
Nominal air gap "a" (Fig. 6)	[mm]	0,2 ^{+0,1} _{-0,05}	0,2 ^{+0,15} _{-0,05}	0,2 ^{+0,15} _{-0,05}	0,3 ^{+0,15} _{-0,05}	0,3 ^{+0,15} _{-0,05}	0,5 ^{+0,15} _{-0,1}	0,5 ^{+0,15} _{-0,1}
Max. working air gap	[mm]	0,6	0,8	1,0	1,2	1,5	1,8	2,0
Max. permitted centre offset "V" (Fig. 6)	[mm]	0,05	0,05	0,05	0,05	0,1	0,1	0,1
Tightening torque cap screws (19)	[Nm]	1,1	2,9	5,7	9,9	24	48	83

³⁾ Please observe the run-in guidelines and minimum speed acc. Table 2.

⁴⁾ On Type 540.140 / Sizes 7 - 9, installation of a key into the driver flange (10) is absolutely necessary for safe torque transmission.

Installation and Operational Instructions for ROBATIC®-clutch Type 540.1 _ _ Sizes 3 – 9

(B.5.1.GB)

State of Delivery

Please check the state of delivery immediately according to the Parts List!
mayr® will take no responsibility for belated complaints.
Please report transport damage immediately to the deliverer.
Please report incomplete delivery and obvious defects to the manufacturer.

Function

ROBATIC®-clutches are energised to engage, electromagnetic pole face clutches.
By applying DC voltage to the magnetic coil in the coil carrier (3), a magnetic field is built up. This attracts the armature disk (9) against the rotor (1 or 2).
The torque is transmitted via frictional locking.



In new condition, torque transmission first takes place via the metal external pole on the rotor (1 or 2) and, after a short operation period, then additionally via the internal pole. After the entire run-in procedure, an even frictional combination occurs on the metal poles and on the friction lining lying between them.

Design

ROBATIC®-clutches feature electrical Protection IP 54 and Insulation Material Class F (up to 155 °C) for the coil, the casting compound and the connection strands.
On designs with a connection terminal, the connection terminal itself corresponds to Protection IP00.
At a duty cycle of 100%, the coil carrier temperature is approx. 65 °C.
The surfaces of the coil carrier (3), the rotor (1 and 2) and the driver flange (10) are phosphated, the armature disk (9) is gas nitro carburated (ground friction surfaces), and the transmission spring is made of stainless steel.
The clutch rotor (1 or 2) is delivered pilot bored or finish bored with a keyway acc. DIN 6885. If the rotor bore and keyway are produced customer-side, the Guidelines on page 6 of the Installation and Operational Instructions on "Boring the Rotor Hub" must be observed!

Explanation of Terms

The **nominal torque** M_2 is the largest transmittable torque (after run-in has been completed), with which the closed clutch can be loaded without slipping occurring.

The **friction work** Q_a is the friction work per acceleration.

The **relative duty cycle** is the ratio of duty cycle to backlash duration in percent (% duty cycle).

Torque Characteristics

In new condition, c. 50 % of the catalogue nominal torque (M_2) is transmitted.

The components reach the catalogue nominal torque when the friction surfaces are run in. Please take c. 100 – 200 switching actions in dynamic operation, a typical speed of c. 500 to 1000 rpm and a medium friction work (see Table 2) as rough reference values.

Longer slipping on the clutch, especially at low speeds, is to be avoided, as this can lead to scoring and therefore to damage to the friction surfaces.

Clutches used in static or virtually static operation do not reach the nominal torque (M_2) stated in the Technical Data (Table 1).

On request, the clutches can be run in manufacturer-side. In this case, please ensure that the customer-side installation is carried out exactly according to the specifications, in order to re-create the best possible friction conditions. Also, the "friction carbon" must not be wiped away.

If the clutches are run in manufacturer-side to the nominal torque and then used in static or virtually static operation, please expect a reduction in nominal torque of c. 60 to 70 %.

This is the case if the clutch under-runs the speed n_{min} or friction work Q_a stated in Table 2.

Table 2: Technical Data for Run-in Procedure

Size	Min. friction work Q_a [J]	Min. clutch speed n_{min} [rpm]
3	16	300
4	29	250
5	55	200
6	105	160
7	200	130
8	380	120
9	600	100

Run-in Conditions

Please carry out an "artificial" run-in, if a run-in procedure on the machine is not possible for the application (see section "Torque Characteristics"). This is the case e.g. when the friction work, the speed or the switching frequencies are too low.

Run-in Possibility 1

- ❑ Apply a voltage of c. 1/3 of U_{nom}
(Do not apply nominal voltage!)
- ❑ Speed On Sizes 3 - 6: c. 50 rpm,
On Sizes 7 - 9: c. 30 rpm
- ❑ Approx. 2 – 3 minutes slipping against blocked output

Run-in Possibility 2

- ❑ Synchronize against unblocked output by producing a larger rotating mass, and / or synchronize at higher speed (values should lie above the minimum values stated in Table 2).
- ❑ Allow to synchronize c. 2 - 3 minutes

General Installation Guidelines

- ❑ Mount or push on the clutch using a suitable mounting device.
Do not mount onto the shaft by hitting with a hammer.
- ❑ Support the coil carrier (3) against twisting (Fig. 3).
- ❑ The friction surfaces of the rotor (1 or 2) and the armature disk (9) must be kept free of oil and grease.
- ❑ Remove the clutch from the shaft over the snap ring groove on the coil carrier (3) using a locking ring (Fig. 4), or over the tapped holes on the rotor facing side (only on rotor Type 540. 100 / Fig. 5).
The locking ring (Fig. 4) is not included in delivery.

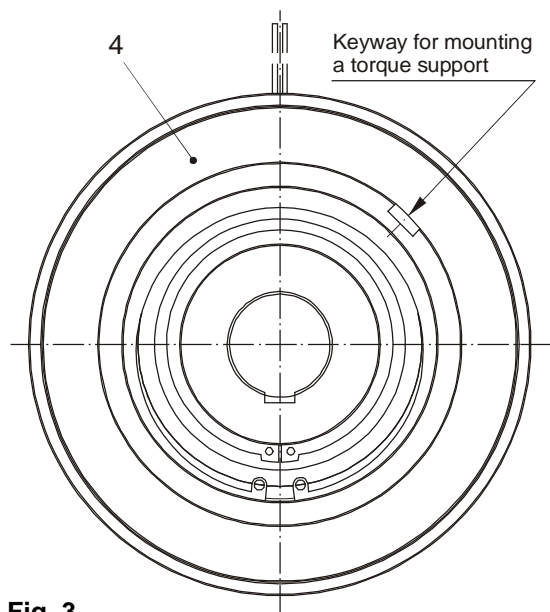

Fig. 3

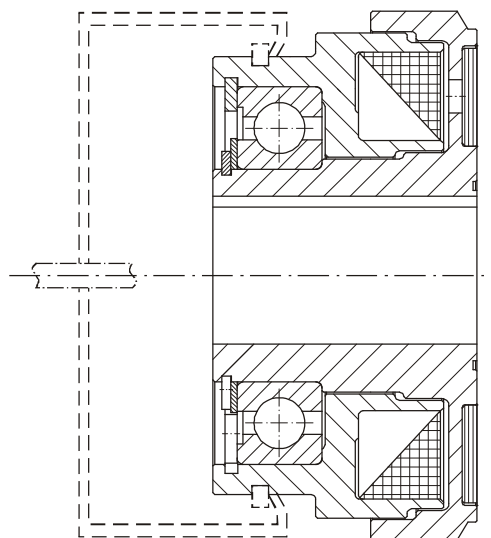

Fig. 4

Boring the Rotor Hub (Fig. 5)

The rotor (1 or 2) must not be bent during boring. Do not put pressure on the outer, thin-walled area of the rotor (1 or 2), see Fig. 5.

In order to bore, clamp the rotor (1 or 2) onto the hub, as depicted in Fig. 5.

The maximum permitted bore diameter d_{max} , acc. Table 1, must not be exceeded.

We recommend H7/k6 as a suitable hub-shaft tolerance.

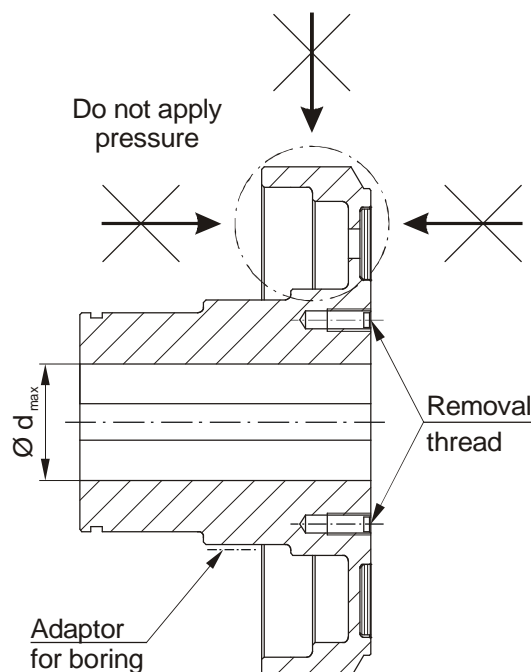

Fig. 5

Installation and Operational Instructions for ROBATIC®-clutch Type 540.1 _ _ Sizes 3 – 9

(B.5.1.GB)

Installation of Type 540.100 (Fig. 1)

1. Press the deep groove ball bearing (4) onto the outer ring in the coil carrier (3) and secure using the locking ring (5).
2. Press the coil carrier (3) inc. the deep groove ball bearing (4) onto the bearing inner ring up to the rotor (1) contact. Align it axially backlash-free with the shim rings (6 and 7) and secure using the locking ring (8).

Installation of Type 540.140 (Fig. 2)

1. Press the deep groove ball bearing (4) onto the outer ring in the coil carrier (3) and secure using the locking ring (5).
2. Press the coil carrier (3) inc. the deep groove ball bearing (4) on the bearing inner ring up to contact onto the rotor (2). Align it axially backlash-free with the shim rings (6 and 7) and secure using the locking ring (8).
3. **a) Sizes 3 to 6:**
Press the first deep groove ball bearing (11) on the outer ring into the driver flange (10) and insert a shim ring (21); press the second deep groove ball bearing (11) on the outer ring into the driver flange (10), align it axially backlash-free with the shim rings (12, 13) and secure using the locking ring (14).
- b) Sizes 7 to 9:**
Insert the ball bearing compensation disk (20) and then a shim ring 0,5 mm (22) into the driver flange (10); insert the first deep groove ball bearing (11) into the driver flange (10) by hand (making sure that it moves easily). Then insert the shim ring 0,5 mm (17) aligning to the ball bearing inner ring and insert the second deep groove ball bearing (11) into the driver flange (10) by hand (making sure that it moves easily). Bring the deep groove ball bearing into position using an installation device against the force of the ball bearing compensation disk (20) (0,3 - 0,6 mm before the compensation disk blocks), align it axially with the shim rings (12, 13) and secure using the locking ring (14).
4. Mount the armature disk assembly (9) onto the driver flange (10) and align it to a radial run-out of max. 0,15 mm.



Exception => Size 6:

Position the calculated shim rings (15) on the ball bearing inner ring (11) before installing the armature disk (9) onto the driver flange (10).

5. Tighten the cap screws (Item 19 with spring washer).
Secure the screws with Loctite 243 and observe the tightening torque acc. Table 1!
6. Measure dimension "A" (= armature disk friction surface to bearing inner ring, see Fig. 2).
7. Measure dimension "B" (= rotor friction surface to bearing contact on collar, see Fig. 2).
8. Calculate the shim ring dimension:
Shim ring dimension (15) = "A" + "a" (Table 1) - "B"
9. Mount the calculated shim rings (15) onto the rotor (2). Press the driver flange (Item 10 on the bearing inner ring) onto the rotor (2). Align it axially backlash-free with the shim rings (16 and 17) and secure using the locking ring (18).



Not valid for Size 6, see point 4.

10. Check dimension "a" (acc. Table 1) and correct it if necessary by removing or adding shim rings (15).

Clutch Installation

The mounting components, such as the shafts or flanges, are to be mounted and secured so that no axial backlash is possible and so that the specified dimension "a" (air gap between the rotor (1 or 2) and the armature disk (9)) acc. Table 1 is maintained.

Axial backlash on the mounting components alters dimension "a" and can lead to the rotor (1 or 2) rubbing against the armature disk (9). Additionally, please observe the permitted centre offset "V" of the mounted components on Type 540.100 (see Fig. 6 and Table 1).

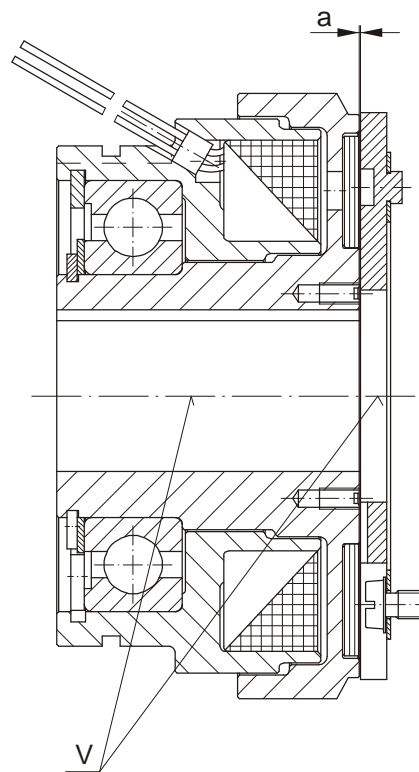

Fig. 6

Electrical Connection

The clutch coil is connected to a DC voltage supply. The voltage value is stated on the Type tag.

Maintenance and Checks

Please check the air gap "a" and the permitted centre offsets "V" acc. Table 1 at regular intervals.

Bearing backlash and wear on the friction surfaces alter the permitted Table values. Apart from this, ROBATIC®-clutches are maintenance-free.

Installation and Operational Instructions for ROBATIC®-clutch Type 540.1 _ _ Sizes 3 – 9

(B.5.1.GB)

Disposal

Our electromagnetic clutches must be disposed of separately as they consist of different materials. Please observe the relevant authority regulations. Code numbers may vary according to the disassembling process (metal, plastic and cable).

Electronic Components

(Limit switch / ROBA®-switch):

Products which have not been disassembled can be disposed of under Code No. 160214 (mixed materials) or components under Code No. 160216, or can be disposed of by a certified disposal firm.

Coil carriers (steel pads with coil / strands)

and all other steel components:

Steel scrap (Code No. 160117)

Clutch rotors (steel pads with friction linings):

Brake linings (Code No. 160112)

Malfunctions / Breakdowns

Malfunction	Possible Causes	Solutions
Clutch does not switch	<input type="checkbox"/> Incorrect voltage applied <input type="checkbox"/> Rectifier failure <input type="checkbox"/> Air gap too large <input type="checkbox"/> Coil interruption	<input type="checkbox"/> Apply the correct voltage <input type="checkbox"/> Replace the rectifier <input type="checkbox"/> Re-adjust the air gap <input type="checkbox"/> Replace the clutch
Clutch does not couple	<input type="checkbox"/> Grease and/or oil on the friction surfaces	<input type="checkbox"/> De-grease the friction surfaces/ run in clutch again



mayr® will take no responsibility or guarantee for replacement parts and accessories which have not been delivered by mayr®, or for damage resulting from the use of these products.